



**INDOOR PACKAGED EQUIPEMENT**

**INSTALLATION, OPERATIONS, MAINTENANCE**

Supersedes: ET145.18-IOM1 (513)

Form ET145.18-IOM1 (115)

**VERTICAL STACKED WATER SOURCE HEAT PUMP  
MODEL VB/VM/VS09-36 CABINET  
AND  
MODEL VSCS09-36 CHASSIS**



LD18014



LD18013

**R-410A**

Issue Date:  
January 21, 2015



# IMPORTANT!

## READ BEFORE PROCEEDING!

### GENERAL SAFETY GUIDLINES

This equipment is a relatively complicated apparatus. During installation, operation, maintenance, or service, individuals may be exposed to certain components or conditions including, but not limited to: refrigerants, oils, materials under pressure, rotating components, and both high and low voltage. Each of these items has the potential, if misused or handled improperly, to cause bodily injury or death. It is the obligation and responsibility of operating/service personnel to identify and recognize these inherent hazards, protect themselves, and proceed safely in completing their tasks. Failure to comply with any of these requirements could result in serious damage to the equipment and the property in which it is situated,

as well as sever personal injury or death to themselves and people at the site.

This document is intended for use by owner-authorized operating/service personnel. It is expected that this individual possesses independent training that will enable them to perform their assigned tasks properly and safely. It is essential that, prior to performing any task on this equipment, this individual shall have read and understood this document and any referenced materials. This individual shall also be familiar with and comply with all applicable governmental standards and regulations pertaining to the task in question.

## SAFETY SYMBOLS

The following symbols are used in this document to alert the reader to areas of potential hazard.



**DANGER** indicates an imminently hazardous situation which, if not avoided, will result in death or serious injury.



**CAUTION** identifies a hazard which could lead to damage to the machine, damage to other equipment and/or environmental pollution. Usually and instruction will be given, together with a brief explanation.



**WARNING** indicates a potentially hazardous situation which, if not avoided, could result in death or serious injury.

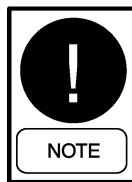

**NOTE** is used to highlight additional information which may be helpful to you.



***All wiring must be in accordance with published specifications and must be performed ONLY by qualified service personnel. The manufacturer will not be responsible for damages/problems resulting from improper connections to the controls or application of improper control signals. Failure to follow this will void the manufacturer's warranty and cause serious damage to property or injury to persons.***

---

**CHANGEABILITY OF THIS DOCUMENT**

In complying with the manufacturer's policy for continuous product improvement, the information contained in this document is subject to change without notice. While ENVIRO-TEC makes no commitment to up-date or provide current information automatically to the manual owner, that information, if applicable, can be obtained by contacting the nearest ENVIRO-TEC service office.

It is the responsibility of operating/service personnel as to the applicability of these documents to the equipment in question. If there is any question in the mind of operating/service personnel as to the applicability of these documents, then, prior to working on the equipment, they should verify with the owner whether the equipment has been modified and if current literature is available.

---

**TABLE OF CONTENTS**

NOTICE & DISCLAIMER.....	4
PREPARING TO INSTALL UNIT.....	4
Literature.....	4
Shipping.....	4
Inspection & Storage.....	4
Pre-Installation.....	4
Rigging.....	5
RISER/CABINET INSTALLATION.....	11
Cabinet Placement.....	11
Supply and Return Piping.....	12
Hoses.....	12
ELECTRICAL WIRING.....	15
Field Installed Power Wiring.....	15
Field Installed Low Voltage Wiring.....	15
Optional Surface Mount Thermostat Connection Wiring.....	15
Optional Remote Mounted Thermostat Wiring.....	15
Optional ADA Door Mounted Thermostat.....	16
ECM Continuous Fan.....	16
CLOSET & DRYWALL INSTALLATION.....	16
ACOUSTIC RETURN AIR PANEL.....	16
SUPPLY AIR DUCTWORK.....	20
Horizontal Supply Air.....	20
Top Discharge Supply Air.....	20
TOP MOUNTED FRESH AIR SUPPLY OPENING.....	23
Top Mounted Fresh Air.....	23
Top Mounted Fresh Air with Motorized Damper.....	23
CHASSIS INSTALLATION.....	25
Units with NPSH Valve Connection and Hose Sets.....	25
Units with NPT-Style (Tapered Pipe Thread) Valve Connection and Hoses.....	25
UNIT START-UP.....	27
Pre-Start-up Checklist.....	27
Initial Unit Start-up.....	27
System Loop Temperature.....	27
FAN SPEED ADJUSTMENT.....	28
MAINTENANCE.....	30
UNIT CONTROLS.....	30
SYSTEM FLUSHING AND CLEANING.....	33
APPENDIX	
Wiring Diagrams.....	34
R-410A Quick Reference Guide.....	38



After installing the unit, show the user how to turn off the electricity to unit. Point out control and switch locations for turning off the electricity. Make sure user understands the importance of following all safety precautions.

## 1. NOTICE & DISCLAIMER

As originally manufactured, this unit contains refrigerant installed by the manufacturer. The manufacturer uses only refrigerants that have been approved for use in the unit's intended country or market. The manufacturer's distributors similarly are only authorized to provide refrigerants that have been approved for use in the countries or markets they serve. The refrigerant used in this unit is identified on the unit's faceplate and/or in the associated manuals. Any additions of refrigerant into this unit must comply with the country's requirements with regard to refrigerant use and should be obtained from the manufacturer's distributors. Use of unapproved refrigerant substitutes will void the warranties and can cause injury or death.

### DISCLAIMER

Customer modifications to ENVIRO-TEC certified products are prohibited.

The manufacturer has certified the product as being compliant with applicable government and/or industry standards. Product certification is designated either on the product itself or in the product literature. The certification mark identifies the applicable standards as well as the Nationally Recognized Test Lab (NRTL) or other testing facility that conducted the testing, where applicable. If changes are made to the product, an engineering review will be needed to assess the impact to the product certification. In some instances, the changes may be such that the NRTL or testing facility will need to review and potentially re-approve of the product by means of a field or site inspection and certification. Any person or entity making changes to the product is responsible for obtaining any necessary engineering review and re-approval. Unauthorized customer modifications to ENVIRO-TEC products are prohibited for the following reasons:

- A. Modifications may create hazards which could result in death, serious injury or equipment damage.
- B. Modifications will void product warranties.
- C. Modifications may invalidate product certifications. Modifications may violate Country standards. Country standards may require that only certified products be used in certain applications, and modifications that result in the loss of product certification may violate those standards.

## 2. PREPARING TO INSTALL UNIT

### A. Literature

Review this Manual and the Users' Manual Information.

After installing the unit, give this Installer's Information Manual to the end user. If you need help on any of the installation instructions or other matters relating to the unit, contact the office where you bought the unit. You may also refer to the unit rating plate for a contact name.

### B. Shipping

Cabinets and risers are shipped in one of the following configurations:

- A. Risers are attached to cabinet, and cabinets are stacked on their side. Chassis ships on separate skids.

- B. Risers ship loose packaged in boxes and sorted by floor. Cabinets ship upright up to 4 per skid. Chassis ships on separate skids.
- C. Risers ship loose in packaged boxes, sorted by floor. Cabinets ship upright on skids with chassis inside cabinet (chassis electrical and water connections are not installed). Cabinet must remain standing upright. Do not place cabinets on their side with chassis inside. Chassis is secured to service panel. Remove screws before removing service panel and chassis.

### C. Inspection & Storage

Cabinets, chassis and risers should be stored in the same way they were shipped. Store in a dry area and ensure chassis units are always in their upright position. If risers are being stored at the job site ensure the ends are capped to prevent contamination.

In areas where construction is not complete—including dry walling, plastering, painting, and where emission of dust particulates or fumes from out-gassing are present—all precautions must be taken to protect the cabinet, cabinet openings, and chassis from physical damage and contamination by foreign material.

- A. Check the unit for indications of damage in shipment. Notify the Transportation company of any damage and note the damage on the shipping receipt.



**Rough handling may dislocate and damage internal components.**

- B. Check riser projections at each end of the cabinet for misalignment or end damage that would prevent making an acceptable connection.
- C. Thermostats and other accessories which have been shipped separately should be inspected for quantity and transit damage.
- D. Store the refrigeration chassis in the normal upright orientation to maintain oil in the compressor sump.

### D. Pre-Installation

- A. Verify the model number on the unit nameplate with the ordering and shipping information, to ensure the correct unit has been shipped.
- B. All cabinets may not be equipped with the same size riser, or the same air supply grille arrangement. Carefully inspect each unit before delivery to the installation site. In most cases, each cabinet will be individually tagged for a specific location in the building.
- C. Keep the cabinet sealed with the shipping materials until all plastering, painting and construction work is complete.
- D. Remove the inner service panel, and manually check the blower wheel for free rotation.
- E. Match the refrigeration chassis to the proper cabinets by referring to the cabinet and chassis nameplate and label information.
- F. Remove the chassis refrigeration access panel (top cover) and inspect the unit. Ensure that the refrigerant tubing is free from obvious physical damage and kinks, and **check that piping does not touch other unit components.**

- G. The compressor is mounted on neoprene isolators with metal spacing sleeves inside and secured with nuts, which must be snug against the metal spacer sleeves.
- H. Inspect all electrical connections. Connections must be clean and tight at the terminals.



**DO NOT USE THE RISERS TO LIFT THE CABINET ASSEMBLY!**



**DO NOT install this unit outdoors.**



**A compressor/unit comprises a pressurized system. Never Loosen threaded joints while the system is under pressure and never open pressurized system parts.**



**Before servicing, open and tag all disconnect switches.**



**Do not install units in a flammable environment due to the danger of an explosion.**



**Safety guards, shields, barriers, covers and protective devices must not be removed while the compressor / unit is operating.**



**All safety features, disengagement and interlocks must be in place and function correctly before the equipment is put into operation. Never by-pass or wire around any safety device.**



**Use gloves and protective goggles and where appropriate, make sure to have a gas mask close at hand. Also use electrical protection equipment and tools suited for electrical operation purposes.**



**Personnel must be qualified according to national safety rules and regulations.**



**The system should be installed by manufacturer-qualified personnel. If not, it may cause water leakage, electric shock or fire.**

#### **E. Rigging**



Follow all applicable regulations and safety practices during rigging and lifting. Prepare and follow written rigging and lifting plan. Lifting must be directed by trained professional rigger. Spreader bars must be used and be long enough to prevent rigging from contacting unit. Use all and only designated lift points according to unit's Manual(s). Locate center of gravity through trial lifts to account for possible variations in unit configuration. Use rigging and lifting techniques that keep unit stable and level. Keep clear of unit when lifted.

FIGURE 1 – Cabinet & Chassis Model Nomenclature

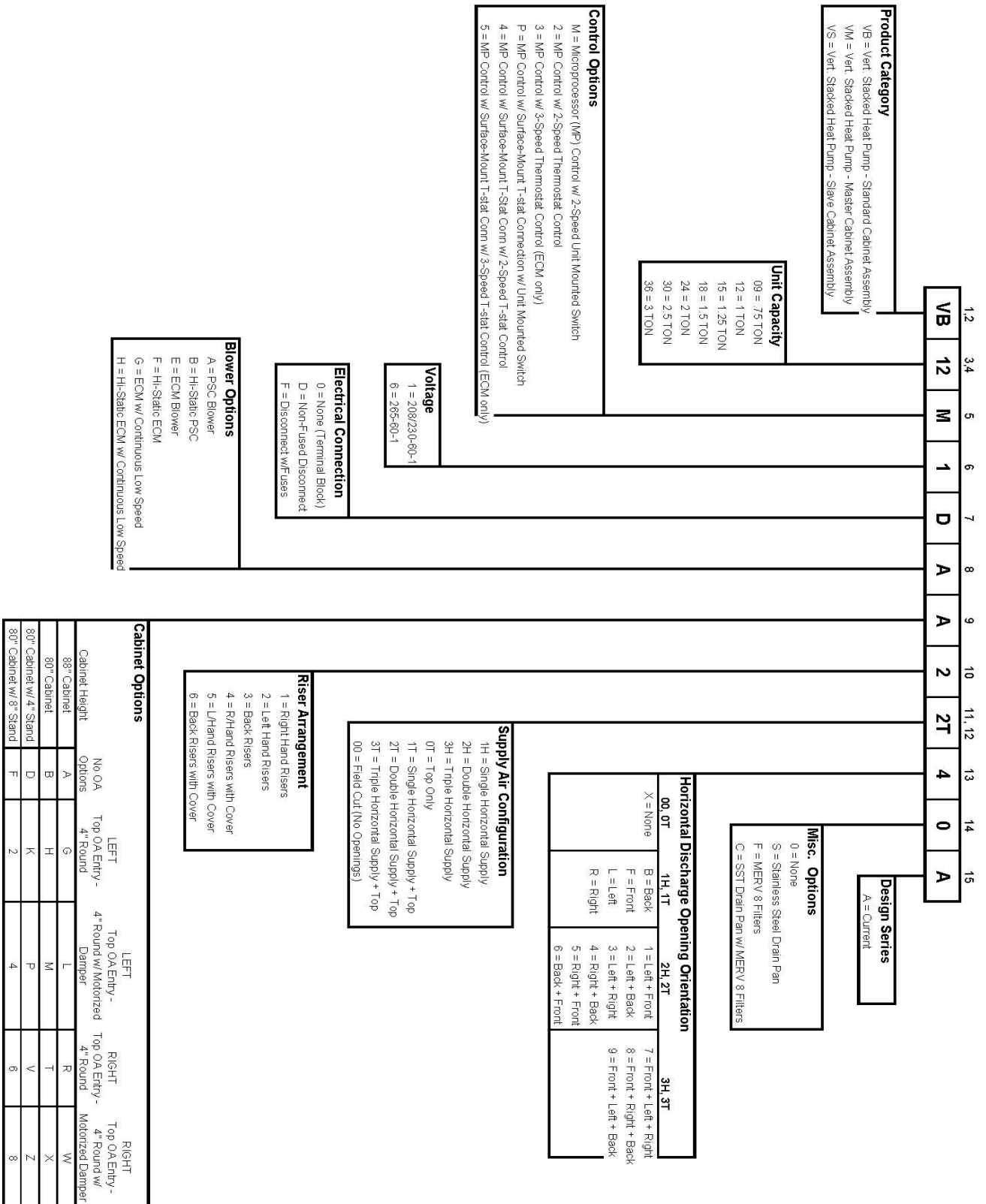

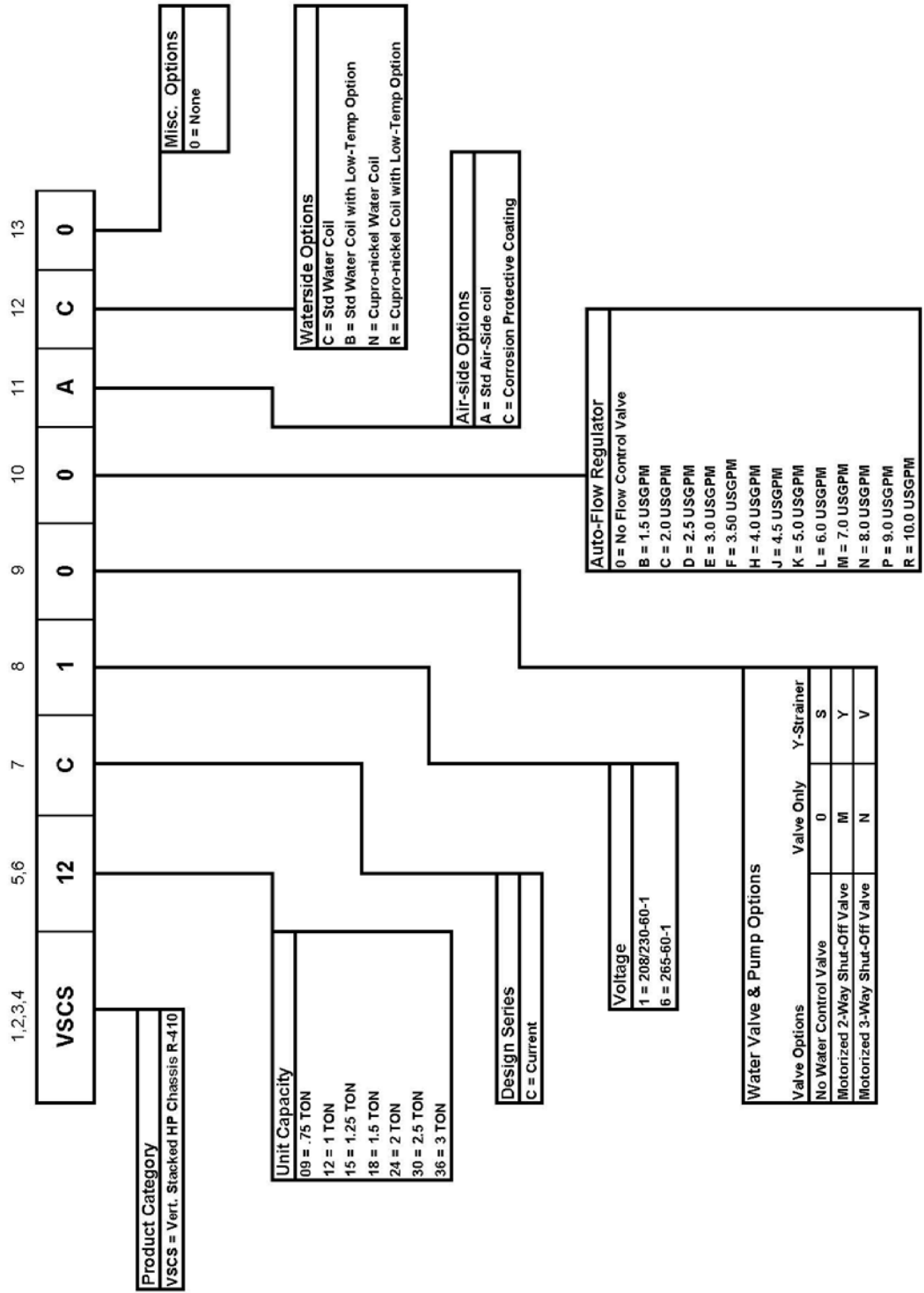

**TABLE 1 – Physical Data**

Model Series	09	12	15	18	24	30	36
Nominal Cooling (Ton) <sup>1</sup>	0.75	1.0	1.25	1.5	2.0	2.5	3.0
Compressor Type	Rotary			Scroll			
Refrigerant Charge (oz)	21	25	34	38	44	48	50
Air Coil-Type	Enhanced Copper Tubes, Enhanced Aluminum Fins						
Face Area (sq ft)	1.46	1.56	2.35	2.35	2.63	3.33	3.33
Rows/FPI	2/16	3/14	3/14	3/14	3/14	3/14	3/14
Water Coil-Type	Enhanced Surface Co-Axial						
Standard Blower/Motor	DWDI Forward-Curved Centrifugal / PSC Direct-Drive						
Diameter x Width (in)	9x4T	9x4T	9x7T	9x7T	9x7	9x8	9x8
Motor HP	0.10	0.10	0.17	0.17	0.25	0.33	0.50
Hi-Static Blower/Motor	DWDI Forward-Curved Centrifugal / PSC Direct-Drive						
Diameter x Width (in)	9x4T	9x4T	9x7T	9x7T	10x7T	10x8T	10x8T
Motor HP	0.10	0.10	0.17	0.25	0.33	0.33	0.50
ECM Blower/Motor	DWDI Forward-Curved Centrifugal / ECM Direct-Drive						
Diameter x Width (in)	9x4T	9x4T	9x7T	9x7T	10x7T	9x8	9x8
Motor HP	0.33	0.33	0.33	0.33	0.33	0.50	0.50
Hi-Static ECM Blower/Motor	DWDI Forward-Curved Centrifugal / ECM Direct-Drive						
Diameter x Width (in)	9x4T	9x4T	9x7T	9x7T	10x7T	10x8T	10x8T
Motor HP	0.33	0.33	0.33	0.33	0.33	0.50	0.50
Filter Quantity-Size (in)	1-14x25x1	1-14x25x1	1-16x30x1	1-16x30x1	1-16x30x1	1-20x30x1	1-20x30x1
Cabinet Weight (lb) <sup>2</sup>	130	130	145	145	150	175	175
Chassis Weight (lb)	70	75	95	100	140	155	160

1) Nominal Capacity calculated in accordance with ARI/ISO Standard 13256-1 for Water Loop Application.

2) Cabinet weight is approximate and does not include weight of risers.



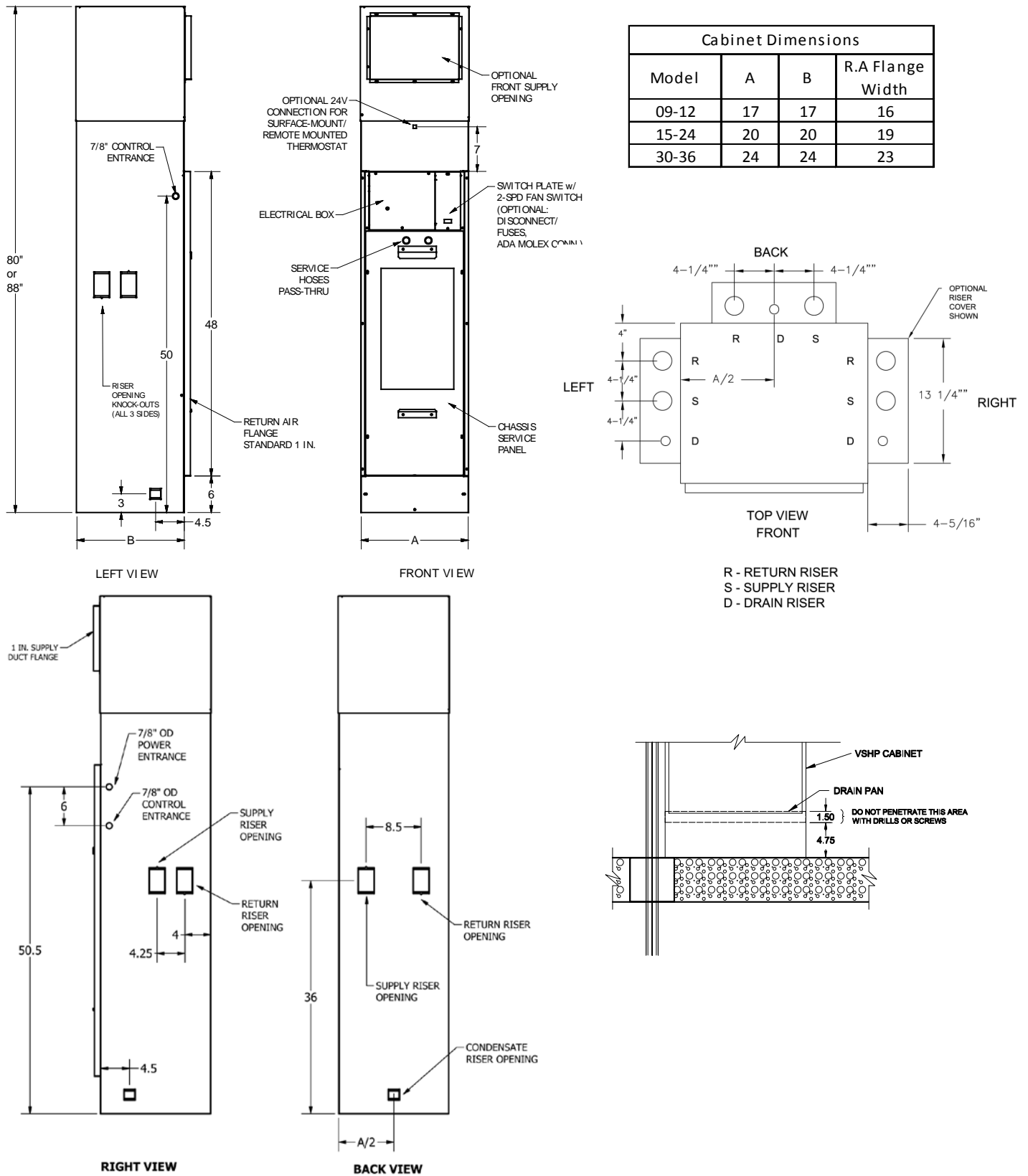

Note:

- 1) Supply, Return, and Condensate riser openings are pre-punched on all sides and field convertible. Cut tabs to remove knock-out.
- 2) Supply and Return openings are 4" x 2.5". During riser installation, ensure stub-out is centered in supply and return openings.
- 3) Condensate P-trap is accessible from front by removing bottom cover plate.
- 4) Riser and shut-off location is measured from base of cabinet and does not include stand height.

**FIGURE 2 – Cabinet Unit Dimensions & Floor Sleeve Dimensions**

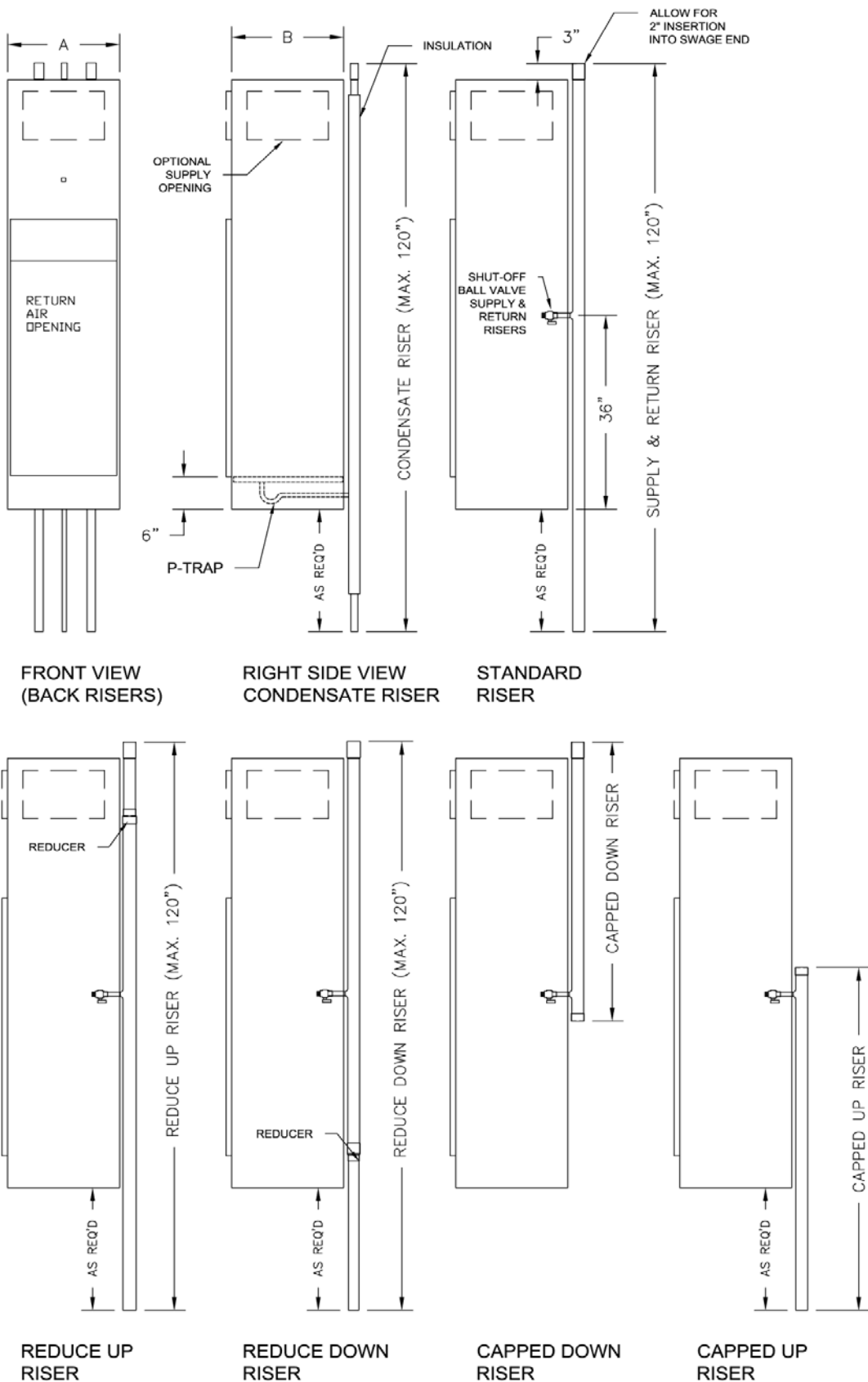

Note:  
1) Riser shut-off valve is measured from base of cabinet and does not include stand height.

FIGURE 2A – Cabinet Riser Dimensions

3. RISER / CABINET INSTALLATION

A. CABINET PLACEMENT

Refer to Figure 2, which shows the correct location of the cabinet in relation to the floor sleeve and risers.



**Do not use the risers to lift or move cabinets.**

Risers must not be used to lift cabinets. Risers are not designed to support or lift any part of the cabinet. Risers are attached using nylon ties to allow for slight adjustments during installation, and expansion of riser column during operation. Care must be taken during installation to avoid damage to risers and riser stub-outs.



**Improper handling and installation of risers could damage riser stub-outs and valves could result in property damage, death or serious injury.**



**Do not allow the risers to bottom out. Riser stub-out should be centrally located with cabinet riser stub-out opening. Do not allow riser stub outs or risers to contact cabinet sheet metal.**



**Do not drag risers on floor while moving the cabinet.**

For orders where risers are shipped loose, riser installation can be done first before installation of cabinets. During riser installation ensure riser stub-outs will be centered in the cabinet openings. Do not allow risers to bottom out in swage.

Where risers are shipped attached to cabinets, installation of risers and cabinets is done at the same time without the need to detach risers from cabinet.

1. Place the cabinet in a horizontal position on the floor adjacent to its installation location (when risers are attached to cabinet).
2. The units are designed to accommodate a maximum supply and return riser stub-out movement of 1-1/2 inches, due to expansion and contraction (total movement of 3 inches). If the total calculated riser expansion or contraction exceeds 1-1/2 inches, field installed expansion compensation must be provided.

The initial positioning of the riser stub-out is correct when the top of the riser pipe is 3 inches above the top of the cabinet (applies to standard riser models only: VBR/VMR/VBS)

3. If the installation requires the use of field or factory provided riser extensions, install the extensions to the unit-mounted risers prior to moving the cabinet into final position.
4. Raise the cabinet upright and lower the risers through the floor cut-out, aligning the risers into the swaged section of the unit on the floor below.

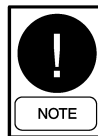

**Take extra care not to scrape or dent risers during positioning. The riser tailpiece should insert approximately 2" into the 3" long swaged section of the unit below.**



**To ensure correct riser positioning, and to compensate for variations in floor-to-floor dimensions, DO NOT allow the riser tailpiece to bottom out into the swaged section.**

5. Center the risers in the pipe chase, and level the cabinet using shims as necessary.
6. Plumb risers in two planes to assure proper unit operation and condensate drainage.
7. Placing cabinets on vibration isolation pads is recommended to reduce noise transmission into floor. Anchor cabinets into place, using sheet metal angles.



**Do not drill, or drive screws into the cabinet in the area of the internal drain pan.**

8. Center the risers' horizontal stub-outs (complete with factory-installed shut-off valves) in the cabinet slot openings. Ensure that the stub-outs are perpendicular to the side/back panel.
9. Verify all risers are vertical and that they penetrate the swaged joint at least 1". Factory provided risers come with a 3 inch deep swage. **Do not allow risers to completely bottom out at 3 inches in the swage.** The 3 inch swage depth is oversized to allow for adjustments if necessary to keep riser stub-outs and valves centered in the cabinet opening. Riser stub-out should be centered in cabinet opening to allow for expansion and contraction. Riser stub-outs must not contact on any sheet metal opening, otherwise damage can occur to stub-outs, resulting in water leaks and property damage.

**Correct Position of Stub-Out in Cabinet Riser Opening:**

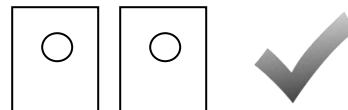

**Incorrect Position of Stub-Out in Cabinet Riser Opening:**

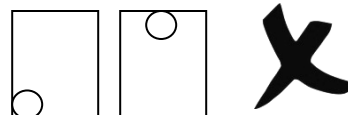

10. Braze or solder riser joints with industry accepted solder or brazing rod material.



**Riser system must be secured to building structure. Cabinets are not designed to support riser system.**

11. **The riser system must be secured, at a minimum of one point, to the building structure. Cabinets are not intended to support riser system!** If the temperature range of the system will exceed the allowed expansion and contraction limits (1-1/2 inches maximum), riser compensation provisions must be made by the installing contractor.

12. Ensure that individual unit shut-off valves remain closed until the circulating loop system has been cleaned and flushed.

## B. SUPPLY AND RETURN PIPING

1. Install a drain valve, shut-off / balancing valves, flow indicators, and drain tees at the base of each supply and return riser to enable system flushing, balancing, and servicing.
2. Install strainers at the inlet of each circulating pump.
3. Insulate loop water piping that runs through unconditioned areas of the building, or outside the building. When loop water temperature is maintained between nominal operating limits of 60-90°F, piping will not sweat or suffer undue heat loss at conditioned space temperatures.
4. Install vents in piping loop as required to bleed residual air from the piping system during filling and servicing.
5. Refer to the following diagrams for determining what riser shut-off valves and hose kits are required for job specific site conditions.
  - A. Factory supplied risers will come with the appropriate hose kits with NPSH type fittings (see Diagram A). Before attaching hoses check that the female end gasket is not missing and free of damage or debris. See Table 3 below for information on replacement gaskets.
  - B. For field supplied risers we recommend ordering the appropriate NPSH type field hose kits from the factory, complete with shut-off valves. Shut-off valves are to be field sweat connected to risers (see Diagram B).
  - C. Legacy chassis with NPT type connections and matching risers with NPT shut-off valve connections require a special hose kit complete with NPT to NPSH swivel adapter on the shut-off valve and chassis connection (see Diagram C) to mate to factory hoses.

## C. HOSES

Ensure the correct hose set is matched with the compatible unit size, see Table 2. When installing NPSH factory provided hoses installer must follow these procedures when installing hoses:

1. Inspect for missing or damaged hose gasket, see Table 3 for replacement gasket part numbers.
2. Tighten by hand screw connections to male NPSH fitting on shut-off valve. Hold ferrule stationary when tightening.
3. Tighten by hand then using a back up wrench tighten a further quarter (1/4) turn only. Do not over-tighten!



**When installing hoses do not apply a twist or torque load on the hose.**



**When tightening hoses hold ferrule stationary by hand while tightening the screw connections. Avoid tight bends or water flow and high pressure drops may occur.**



**Hose gasket does not require extreme tightening to obtain a seal. DO NOT OVERTIGHTEN or damage to gasket or sealing surface will occur. Do not apply thread sealant.**

**Table 2: Chassis Hoses**

CHASSIS MODEL	HOSE TYPE
09/12/15/18	1/2" NPSH FEMALE-FEMALE
24/30/36	3/4" NPSH FEMALE-FEMALE

**Table 3: Replacement Hose Gaskets**

REPLACEMENT GASKETS FOR NPSH HOSE KITS	
Part No.	Description
VSGK-UFHW-050	1/2" RUBBER GASKET
VSGK-UFHW-075	3/4" RUBBER GASKET



**HOSES MUST BE HAND TIGHTENED THEN FURTHER TIGHTENED NO MORE THAN 1/4 TURN. DO NOT APPLY EXCESSIVE FORCE!**



**ALWAYS USE A BACK-UP WRENCH WHEN TIGHTENING HOSES TO VALVES! OTHERWISE VALVE SOLDER JOINT MAY FAIL LEADING TO PROPERTY DAMAGE OR SERIOUS INJURY!**

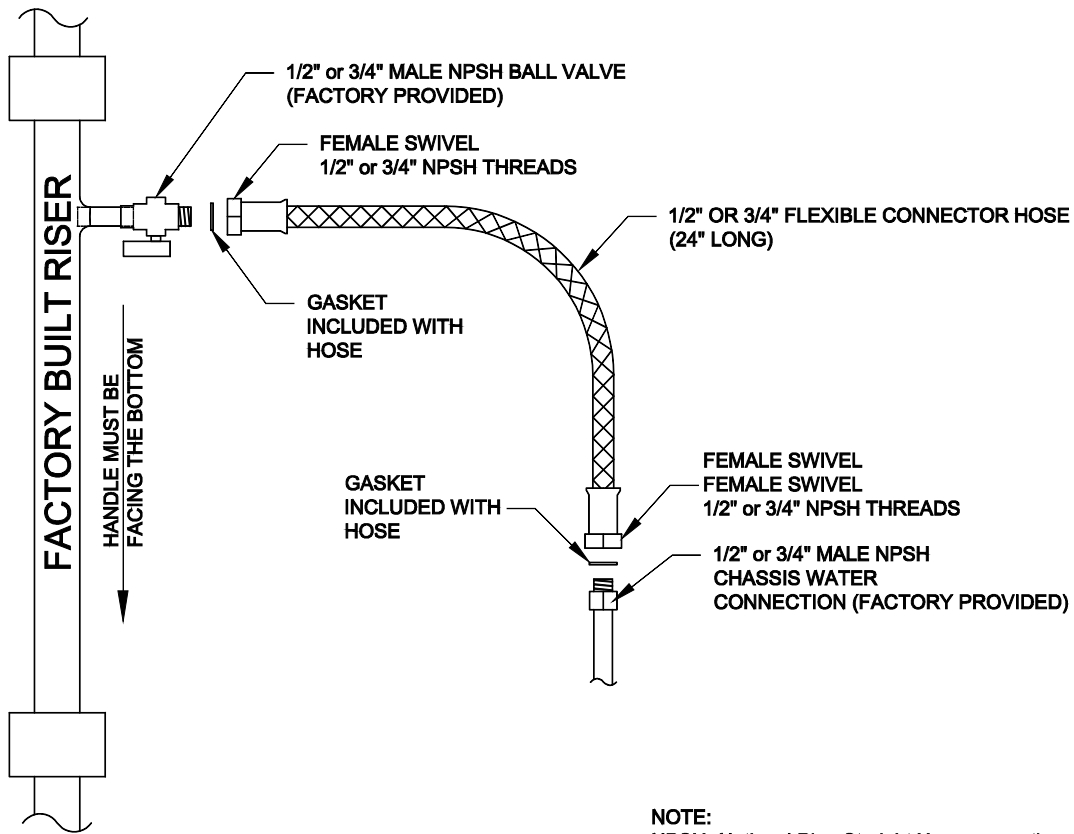

NOTE:  
NPSH- National Pipe Straight Hose connection

Diagram A -Standard Factory Supplied NPSH Hose Kits and Risers (As of June 2013)

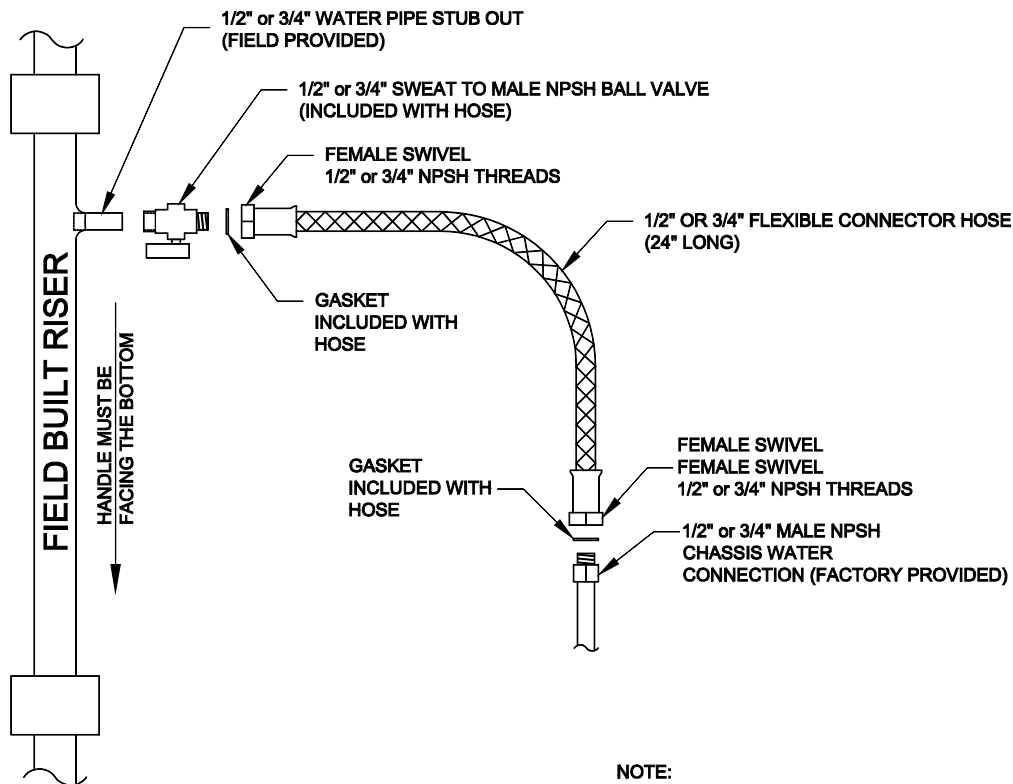

NOTE:  
NPSH- National Pipe Straight Hose connection

Diagram B –Optional Field Supplied Risers w/ Factory Supplied NPSH Hose Kits and Shut-Off Valves

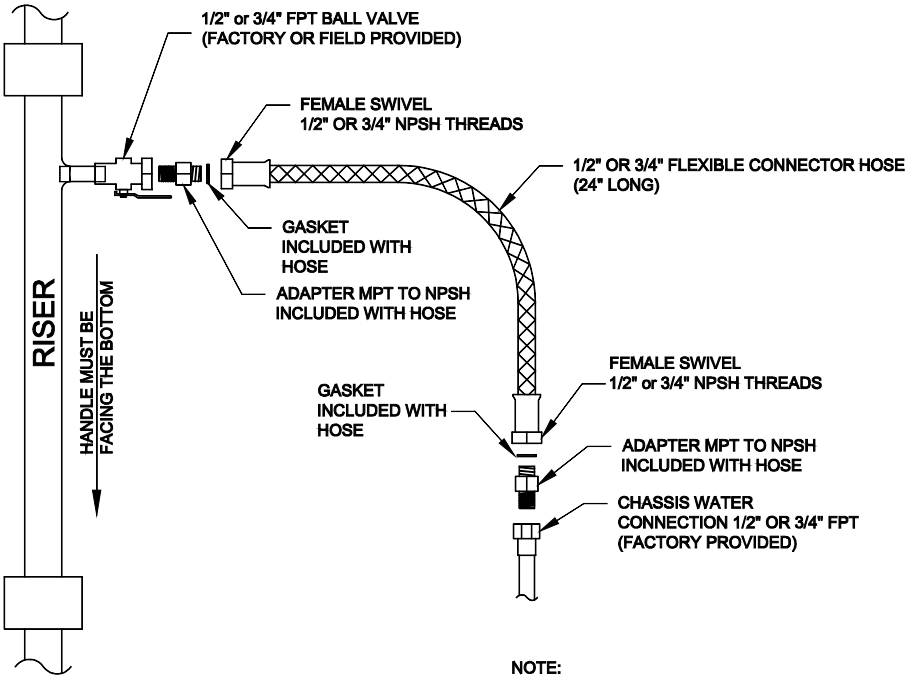

NOTE:  
NPSH- National Pipe Straight Hose connection

\* For VB cabinets built prior to June 2013

Diagram C – Conversion of NPT to NPSH type fittings (VB Units with NPT fittings only)\*

**4. ELECTRICAL WIRING**



**LOCK ALL ELECTRICAL POWER SUPPLY SWITCHES IN THE OFF POSITION BEFORE INSTALLING THE UNIT. FAILURE TO DIS-CONNECT POWER SUPPLY MAY RESULT IN ELECTRICAL SHOCK OR EVEN DEATH.**

**A. Field Installed Power Wiring**

Power wiring to the equipment must conform to National and Local Codes (NEC) by a professional electrician.

Provide each unit with its own separate electrical circuit, means of circuit protection, and electrical disconnect switch. Follow current National Electrical Code ANSI/NFPA 70, CSA C22.1 C.E.C. Part 1, and state and local codes.



**Failure to provide these shut-off means could cause electrical shock or fire, resulting in damage, injury or death.**



**Use Copper Conductors Only!**

Verify that the available unit power supply is compatible with the unit's nameplate rating. Ensure breaker is properly sized as per nameplate. Line voltage supply enters through the right hand side of the cabinet at the 7/8" power entrance knock-out.

Connect to the line side of the factory installed terminal block. Unit terminals are not designed to accept other types of conductors. Failure to use copper conductors may result in equipment damage.

**B. Field Installed Low Voltage Wiring**

Select a location for room thermostat that is away from supply air registers, on draft-free interior wall, and not near lights, television, direct sunlight, or other heat sources.

Thermostat connection within the unit is accomplished by connecting the remote thermostat wiring to microprocessor low voltage terminal strip. See Figure 4 for typical wiring connections.



**Locate thermostat away from supply drafts. Ensure the back of thermostat is sealed and protected from air drafts. Short cycling can result in damage to unit.**

RECOMMENDED WIRE SIZE	MAX. LOW VOLTAGE WIRE LENGTH
20 gauge	50 feet
18 gauge	75 feet
16 gauge	125 feet

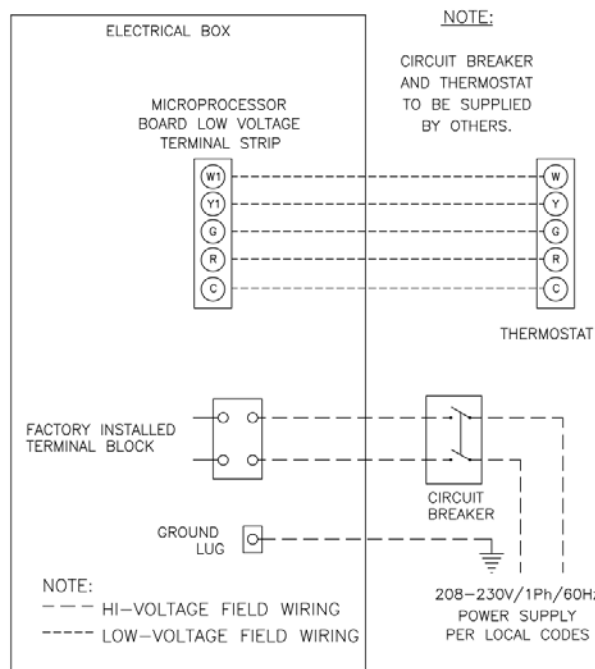
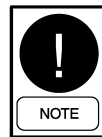

**FIGURE 4 – FIELD WIRING DIAGRAM**

Ensure that the control wiring between the thermostat and the unit's terminations does not exceed 1 ohm.



**Resistance in excess of 1 ohm may cause component damage due to insufficient AC voltage supply.**



**Check all loads and conductors for grounds, shorts, or misfiring. Do not run the low voltage wiring in the same conduit with the high voltage power wiring.**

**C. Optional Surface Mount Thermostat Connection Wiring**

For applications where thermostat is mounted directly above the return air panel, cabinet Control Option 'P' must be selected (i.e. VB12P). Thermostat molex pigtail harness (shipped loose to field) is field wired to thermostat terminals and molex connector clips to mating panel mounted molex connector on unit cabinet, located 7 inches above the electrical box. See optional 24V surface mount connection in Figure 2.

**D. Optional Remote Mounted Thermostat Wiring**

For units ordered with extended thermostat harness option the thermostat is remote mounted and specific extended harness length can be ordered. Extended harness is plenum rated. Use low voltage 7/8" knock-out on the side of the unit at the electrical box to field wire the low voltage thermostat wiring. Using a plastic bushing pass harness inside electrical box to factory wired mating molex harness. See Figure 5 below. Thermostat pigtail molex harness is shipped loose for field wiring to thermostat terminals.

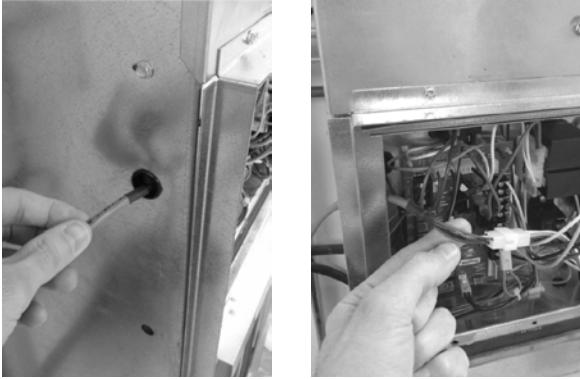

FIGURE 5 – Remote Thermostat Wiring

#### E. Optional ADA Door Mounted Thermostat

For units ordered with ADA thermostat option to meet the Americans with Disabilities Act's (ADA) requirements, thermostat is located on the return air panel door, at a height of 48 inches from the base of the cabinet. Unit is supplied with a custom return air door panel with thermostat mounting holes, unit switch plate with molex connector, and ADA molex pigtail harness. See Section 6, Figure 9A.

Wire leads from ADA thermostat harness are field wired to thermostat terminals. Molex end of ADA thermostat harness is field connected to surface mounted molex connector at unit switch plate.

Mount thermostat using the factory provided 1/4" #8 screws. ADA thermostat harness is plenum rated and will hang in behind the return air door. For chassis servicing, unclip harness from unit switch plate.

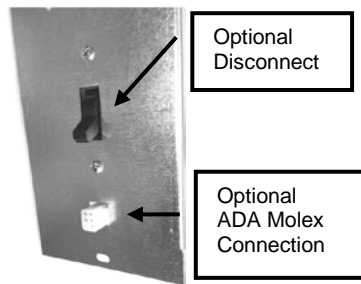

FIGURE 6 – Unit Switch Plate with ADA Thermostat Connection

#### F. ECM Continuous Fan

This option features a factory wired continuous low speed fan circuit. The EC motor (ECM), due to available five motor speed taps, offers ideal range for supporting continuous low speed fan.

Fan will run continuously on low fan speed setting even if there is no demand for cooling or heating. The continuous fan is controlled by a dry contact to provide interlocking to ERV or room occupancy control. See Appendix for electrical schematics.

### 5. CLOSET & DRYWALL INSTALLATION

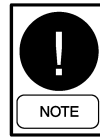

To avoid potential vibration and noise issues the Return Air Panel should not contact any part of the unit cabinet or sleeve. Maintain a sufficient gap between R.A. Panel frame and cabinet!

1. Build a closet enclosure for the cabinet that will incorporate the Return Air panel size while maintaining a sufficient gap between the closet and cabinet to prevent the cabinet from contacting the R.A. panel and closet enclosure. Refer to Section 6 and Figures 7 & 8.
2. Before installing drywall around cabinet, cover the supply and return openings with plastic or cardboard to prevent dust or debris from entering the unit components.
3. Install drywall using conventional construction methods. Studs or drywall should not be fastened directly to the cabinet surface. The spacing of the framing members will be dependent on the return air access and the type /quantity of supply air outlets. See Figures 7 and 8.
4. Install sheetrock around unit cabinet by securing the drywall to building construction studs. Cut holes around the supply air and return air openings to allow access to the unit chassis, unit controls, and the supply air connection.
5. Vacuum all dust and construction debris from the unit drain pan, electrical box, and discharge plenum, after cutting out the supply/returns openings.



To prevent electrical shorts, and drain pan leaks, DO NOT penetrate unit components when driving screws near the unit control box or drain pan. Do not allow screws or nails to penetrate chassis, risers, electrical junction boxes, conduits, or to interfere with chassis removal.

### 6. ACOUSTIC RETURN AIR PANEL

1. Return Air (R.A.) Panel is painted standard "Appliance White". Carefully unpack R.A. Panels from shipping box. R.A. panels with optional key locks require key locks to be field installed to the slot in panel door. ADA R.A. door panels come with an opening and pilot holes mounting a Johnson Controls thermostat. ADA harness for wiring to thermostat and connecting to unit is shipped loose with the thermostats.
2. Locate drywall opening at a distance from the unit that prevents the R.A. panel from contacting the unit sleeve. See Figure 7 & 8. R.A. panel throat opening should be centered to the unit cabinet return air flange opening.
3. Fasten R.A. Panel to frame opening using screws provided. See Figure 7.
4. Refer to Figure 9A showing opening for mounting ADA compliant thermostat at 48" above floor. Note that location of opening on door changes if cabinet is ordered with stand. A left hand opening door is shown. R.A Panel with ADA is not reversible and must be ordered in either Left or Right hand opening configuration, determined by location of door hinge.



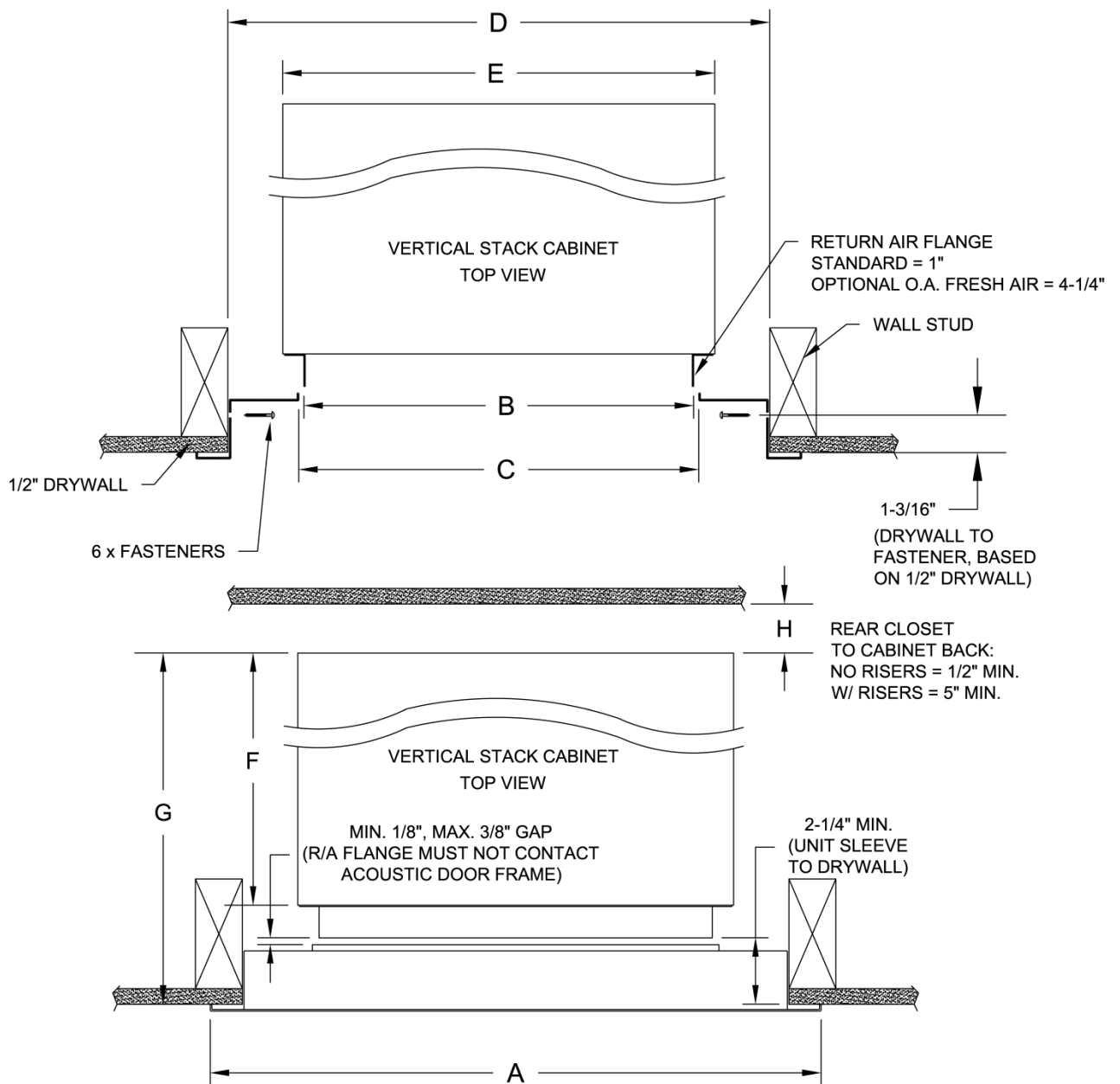

UNIT SIZE	A (Panel Width)	B (Sleeve Width)	C (R/A Panel Opening)	D (Rough In Width)	E (Unit Width)	F (Unit Depth)	G (No OA Option)	G (OA Option)
09 / 12	22 3/4	16	16 1/4	20 3/4 ± 1/8	17	17	20 1/4 MIN. 20 1/2 MAX.	24 1/2 MIN. 24 3/4 MAX.
15/18/24	25 3/4	19	19 1/4	23 3/4 ± 1/8	20	20	23 1/4 MIN. 23 1/2 MAX.	27 1/2 MIN. 27 3/4 MAX.
30 / 36	29 3/4	23	23 1/4	27 3/4 ± 1/8	24	24	27 1/4 MIN. 27 1/2 MAX.	31 1/2 MIN. 31 3/4 MAX.

ALL DIMENSIONS ARE IN INCHES

FIGURE 7 – Critical Return Air Panel with Unit Cabinet Installation Dimensions

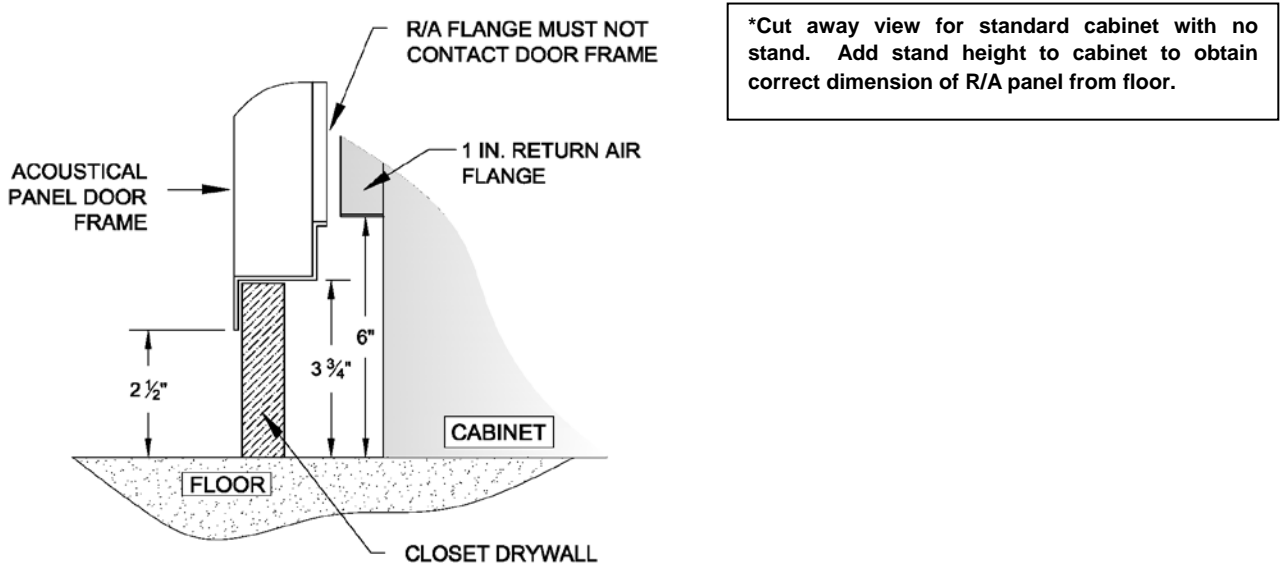

Note:  
1) Dimensions shown do not include optional stand height.

**FIGURE 8 –Return Air Panel Dimensions**

ALL DIMENSIONS ARE IN INCHES						
MODEL	A	B	C	D	ROUGH-IN WIDTH	ROUGH-IN HEIGHT
VSCS09/12	22.75	20.50	16.25	18.50	20.75	52.75
VSCS15/18/24	25.75	23.50	19.25	21.50	23.75	52.75
VSCS30/36	29.75	27.50	23.25	25.50	27.75	52.75

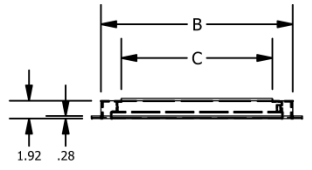

NOTES:  
- Acoustic Panel powder coated in 'Appliance White'  
- Acoustic Panel may be installed on the right hand side, or left hand side

**IMPORTANT:** For maximum R.A. flow, flush mounted acoustic panel must be centered vertically and horizontally over the Return Air opening of the cabinet. Supply air duct collar extensions may be required to prevent short cycling.

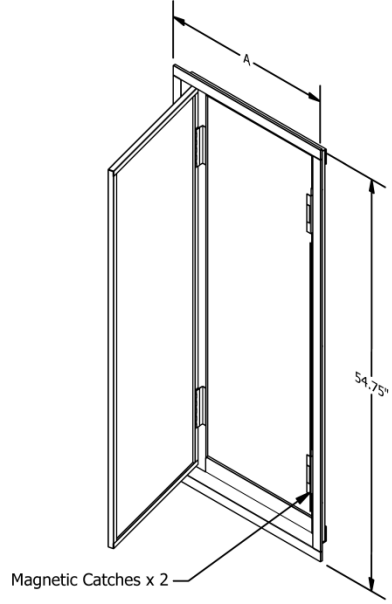
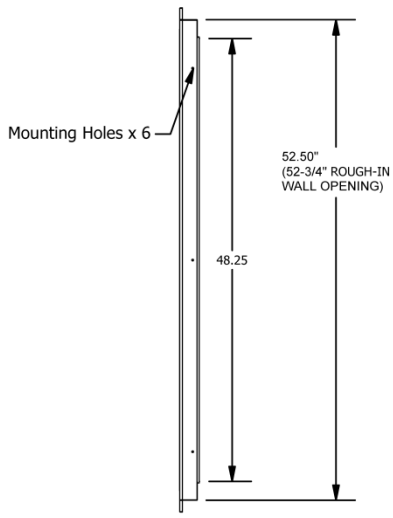
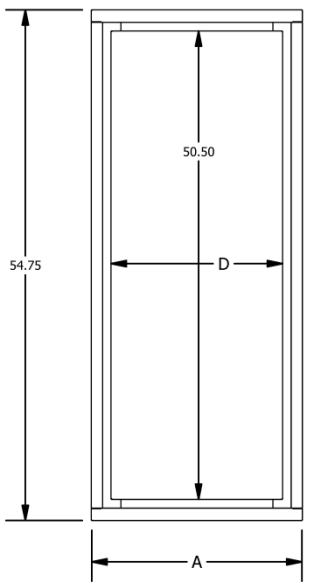

Note:  
1) See Figure 7 for additional R.A. panel and cabinet installation information.

**FIGURE 9 – R.A Panel Cross Section Installation at Floor Level**

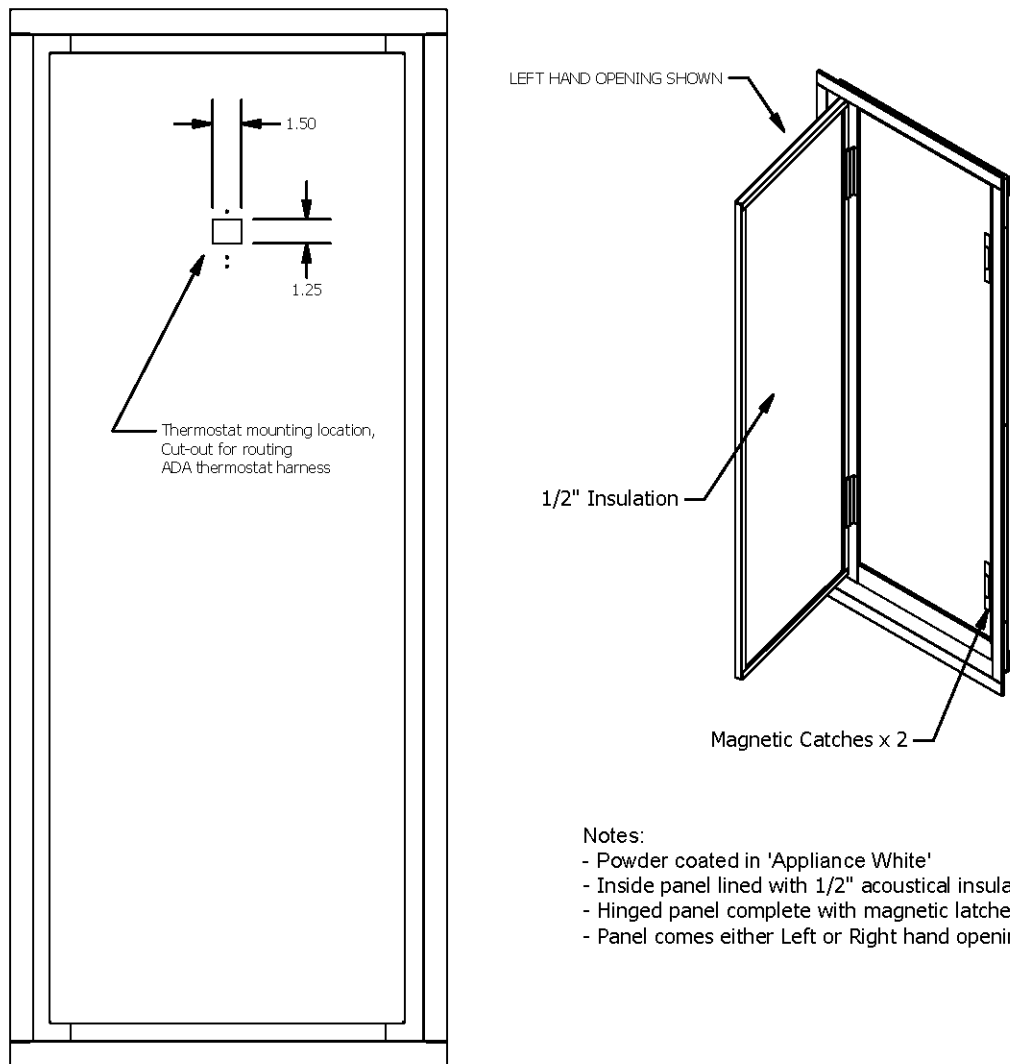

## Notes:

- Powder coated in 'Appliance White'
- Inside panel lined with 1/2" acoustical insulation
- Hinged panel complete with magnetic latches
- Panel comes either Left or Right hand opening

FIGURE 9A – Optional Return Air Panel with ADA Mounted Thermostat

## 7. SUPPLY AIR DUCTWORK



**Installer must ensure there is no direct contact between cabinet sheet metal parts and drywall enclosure. This includes return air and supply air flanges. Failure to follow these instructions will negatively affect unit sound performance.**

### A. Horizontal Supply Air

A 2" duct flange (field provided) may be required to eliminate supply air recirculation when shallow profile, single deflection supply grilles are installed at the cabinet discharge openings. If the discharge from the cabinet is not ducted completely into the conditioned space, air can recirculate into the return air opening from the space inside the drywall enclosure.

JCI supplied grilles shall have a clearance of 1/4" around the perimeter in order to fit inside the unit supply flange. Other grille manufacturers could have different clearances and should be verified.

Field supplied gasket must be applied accordingly in order to prevent air recirculation and vibration transfer when supply grilles are mounted to unit supply opening. When mounting supply grilles with optional volume damper directly to cabinet supply flange, the volume damper will fit inside the cabinet supply flange. It is recommended to apply 1/8" neoprene tape around the perimeter the volume damper prior to inserting into the supply opening. See Figure 11 for an example. This will assist in reducing noise transmission and air recirculation into unit closet

For ducted openings connect the unit supply opening to the supply ductwork using a watertight flexible duct connector. This will minimize the transmission of operating sounds through the supply ductwork. Elbows with turning vanes or splitters are recommended to minimize air noise due to turbulence and to help reduce static pressure.

### B. Top Discharge Supply Air

Units that are installed with a top discharge should be connected to the supply ductwork with a watertight flexible connector. This will minimize the transmission of operating sounds through the supply ductwork. Elbows with turning vanes or splitters are recommended to minimize air noise due to turbulence and to help reduce static pressure.

For information on available unit horizontal and top supply openings see Table 4 on the following page. Recommended face velocity at the outlet supply grille is 300-500 FPM. Table 4 gives face velocity at the unit supply openings in relation to Table 3. To calculate the face velocity at the supply grille, take the FPM from Table 4 and divide by the supply grille free area factor.

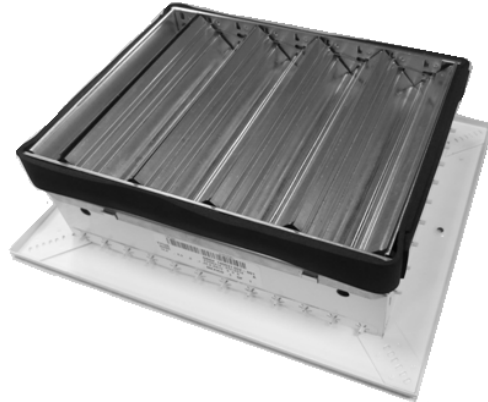

**FIGURE 10 – Supply Grille with Volume Damper and 1/8" Neoprene Tape Applied To Perimeter**

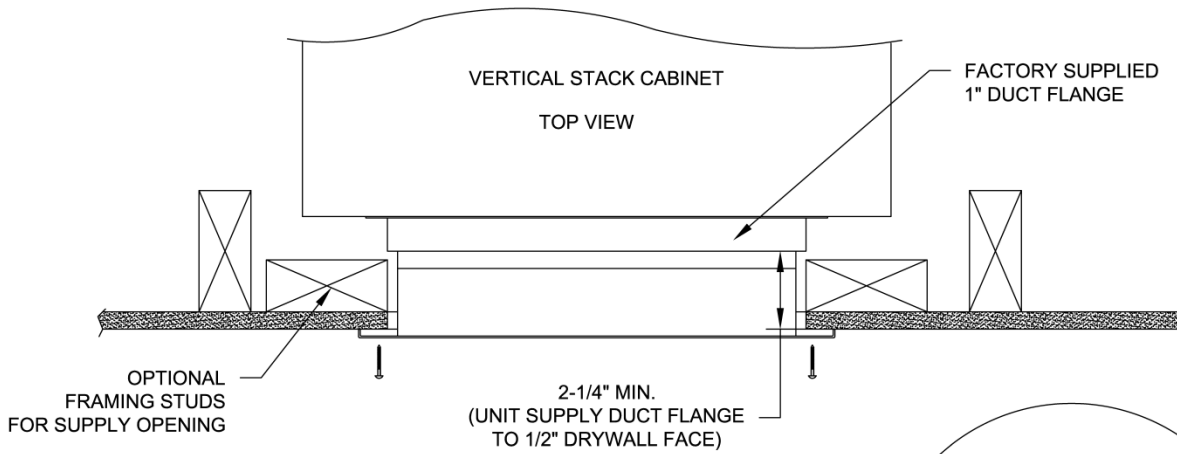
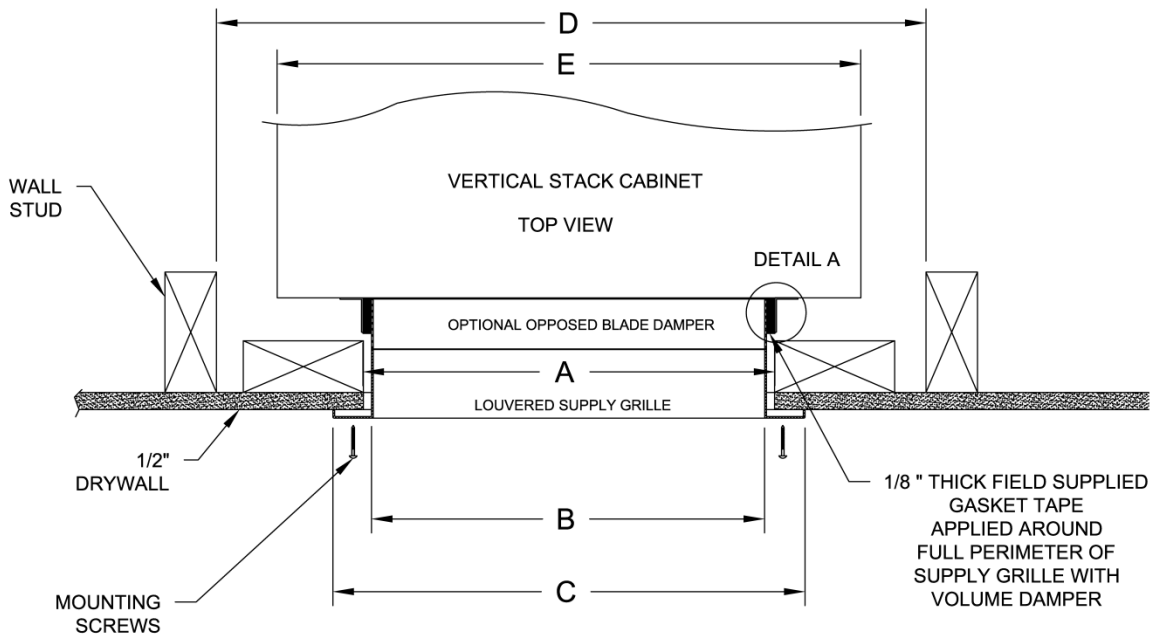

UNIT SIZE	A (Supply Grille Nominal Width)	B (Grille Width)	C (Grille Flange Width)	D (Rough In Width)	E (Unit Width)
09 / 12	X	B=X-0.5"	C=X+1.75"	20 3/4 ± 1/8	17
15/18/24	X	B=X-0.5"	C=X+1.75"	23 3/4 ± 1/8	20
30 / 36	X	B=X-0.5"	C=X+1.75"	27 3/4 ± 1/8	24

ALL DIMENSIONS ARE IN INCHES AND TYPICAL DIMENSIONS FOR JCI SUPPLIED GRILLES ONLY. CHECK DIMENSIONS FOR FIELD SUPPLIED GRILLES AS DIMENSIONS CAN BE DIFFERENT.

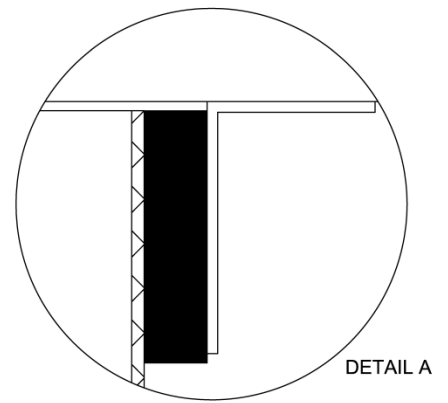

FIGURE 11 – Unit Mounted Supply Grille Installation Dimensions

**TABLE 4 – Unit Supply Opening Sizes****UNIT SUPPLY OPENING SIZES**

Model	Horizontal Openings					Top Opening
	Single Horizontal		Double Horizontal		Triple Horizontal	
	No Top Opening	w/ Top Opening	No Top Opening	w/ Top Opening	No Top Opening	
09	14W x 12H	14W x 6H	14W x 8H	Not Available	Not Available	12x8
12	14W x 14H	14W x 6H	14W x 10H	Not Available	Not Available	12x8
15	16W x 14H	14W x 6H	14W x 10H	Not Available	14W x 8H	14x12
18	Not Available	14W x 6H	14W x 12H	14W x 6H	14W x 10H	14x12
24	Not Available	14W x 10H	16W x 14H	14W x 6H	14W x 10H	14x12
30	Not Available	14W x 6H	20W x 14H	14W x 6H	16W x 12H	18x16
36	Not Available	14W x 10H	Not Available	14W x 6H	16W x 14H	18x16

1. Unit supplied supply grilles will be supplied as double-deflection type.
2. Grilles for unequal airflow applications (i.e. unit-mounted plus ducted supply) shall be provided with integral opposed-blade dampers.
3. All grilles will be supplied in standard "Appliance White" painted finish.
4. Grilles are shipped loose, for field installation upon completion of cabinet/ductwork/drywall installation.
5. Top opening size does not change. When combined with any other discharge arrangement, shall be included in determining horizontal opening grille size.
6. Openings marked 'Not Available' result in face velocities outside the recommended 300-500 FPM range.
7. Hi-Static Blower option is not recommended or single horizontal discharge openings with unit mounted supply grille.

**UNIT SUPPLY FACE VELOCITY (FPM)**

Model	Horizontal Openings					Top Opening
	Single Horizontal		Double Horizontal		Triple Horizontal	
	No Top Opening	w/ Top Opening	No Top Opening	w/ Top Opening	No Top Opening	
09	291	272	219	Not Available	Not Available	510
12	316	344	221	Not Available	Not Available	645
15	354	314	283	Not Available	236	471
18	Not Available	391	294	294	235	587
24	Not Available	397	273	364	291	729
30	Not Available	416	276	339	269	538
36	Not Available	410	Not Available	385	261	610

1. Tabulated Face velocities do not account for supply grille free area factor. Face velocities at supply grille will be higher depending on grille type.
2. Face velocities are based on the nominal rated CFM and in feet per minute (FPM).
3. Face velocities are calculated by taking the average across all openings. Tabulated top opening face velocity is only for units with single Top Opening and no horizontal openings.

**8. TOP MOUNTED FRESH AIR SUPPLY OPENING**

**A. Top Mounted Fresh Air**

The optional fresh air intake provides a 4" round duct connection on top of the unit (see Figure 12, for right and left hand version). The fresh air is discharged upstream of the DX coil through the discharge collector box.



**Do not allow incoming air to bypass the DX coil, otherwise damage to unit may occur.**

Unit can be selected with the fresh air opening located on top left or right hand side for ease of installation.

It is recommended that applications requiring 10% or more outdoor air utilize a pressurized fresh air system. Unit cabinet static pressure at the return air opening is not designed to draw 10% or more in passive fresh air systems.

It is recommended that fresh air with a high humidity ratio is pre-treated before entering unit assembly using energy recovery ventilators or make-up air units. Fresh air duct inside unit is insulated to protect unit from condensation in the event of high humidity air however excessively moist fresh air over prolonged periods can potentially result in condensate inside unit or closet.



**Recommend fresh air is pre-treated before entering unit assembly by energy recovery ventilators (ERV) or make-up air units to avoid condensate developing inside ducts and equipment.**

Unit comes with 4-1/4" return air sleeve. Front supply openings will come with 4-1/4" supply plaster flange.

**B. Top Mounted Fresh Air with Motorized Damper**

Same features as in the top mounted fresh air intake option and including a motorized damper assembly inside the discharge collector box similar to depiction in Figure 12. Damper assembly can be easily removed, for servicing see steps below. Motorized damper assembly opens during FAN ON operation. See Appendix for electrical schematic. For other control options please contact the factory.



**During transportation, handling or installation of the cabinet, excessive handling can cause an inner black plastic cover to come loose and jam the actuator preventing the damper from opening.**

During start-up check that the damper is opening when unit fan is running. It can take 20 seconds to fully open. If damper opens unit is operating as intended.

If it fails to open the cause is likely a loose cover preventing actuator from rotating. To remove actuator and service the damper refer to instructions below:

STEP 1. Looking up underneath top of the return air flange you will notice the damper assembly. Remove seven fasteners holding the damper plate. Drop the plate down, disconnect the quick-connect terminals from the harness.

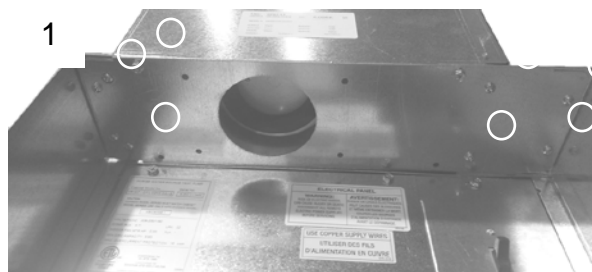

STEP 2. a) Remove red cover from actuator body, b) if black cover has become loose, position it in place, and c) slide back onto actuator.

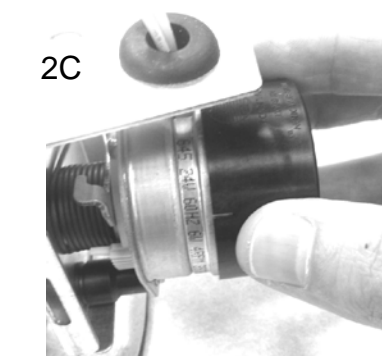
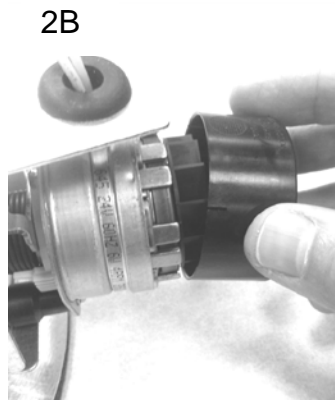
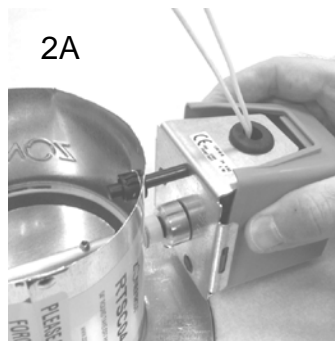

STEP 3. Secure red cover back over actuator assembly. Ensure the plastic tabs are secured to the metal body bracket. Connect quick-connect terminals and insert damper assembly into discharge collector box. Fasten using screws.

FIGURE 12 – Fresh Air Opening – Left Hand and Right Hand Unit Shown

Cabinet Dimensions			
Model	A	B	C
09-12	17	8	12
15-24	20	12	14
30-36	24	16	18

1. Optional Fresh Air option comes with 4-1/4" R.A flange.
2. Optional front supply opening comes with 4-1/4" duct flange.
3. All other openings come with standard 1" duct flange.
4. Left and Right hand versions shown.

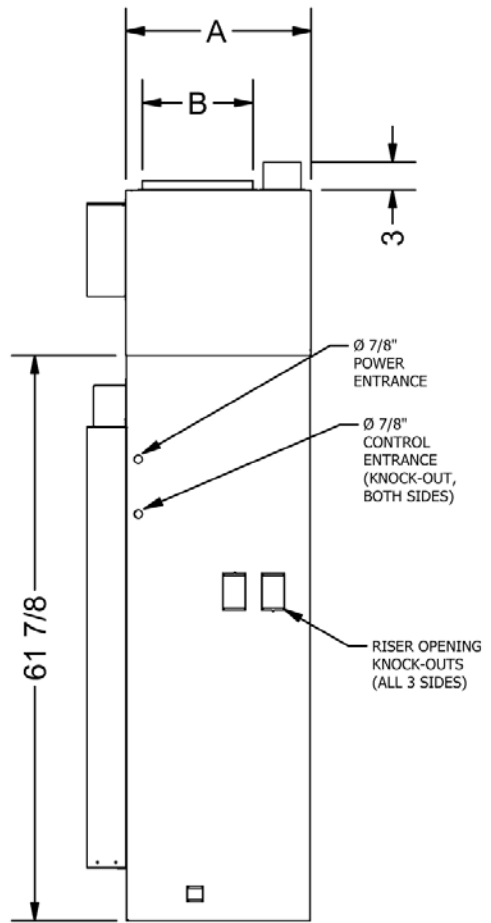
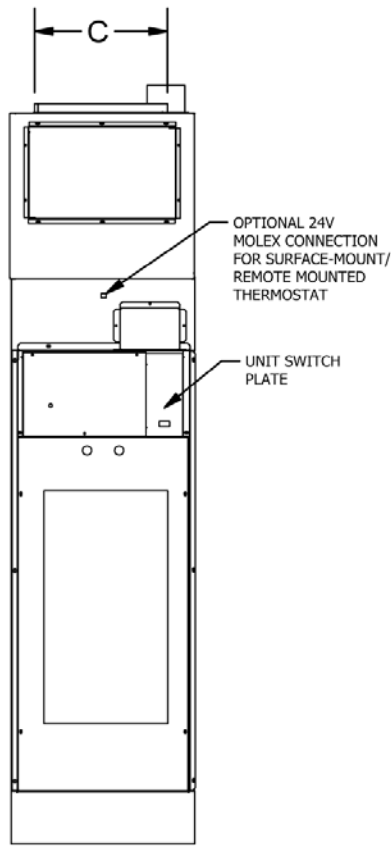
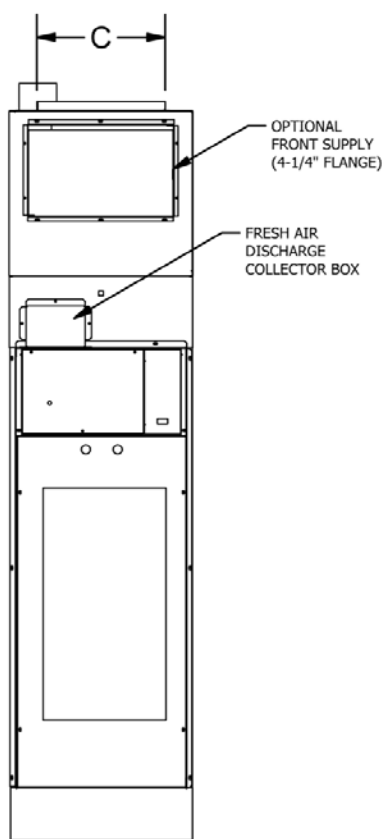
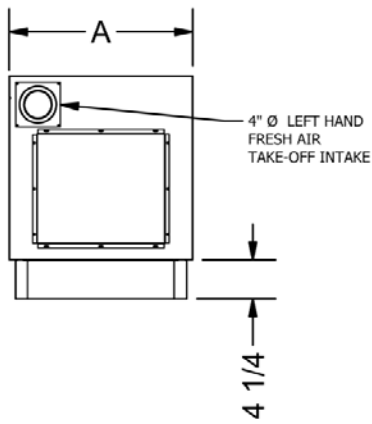
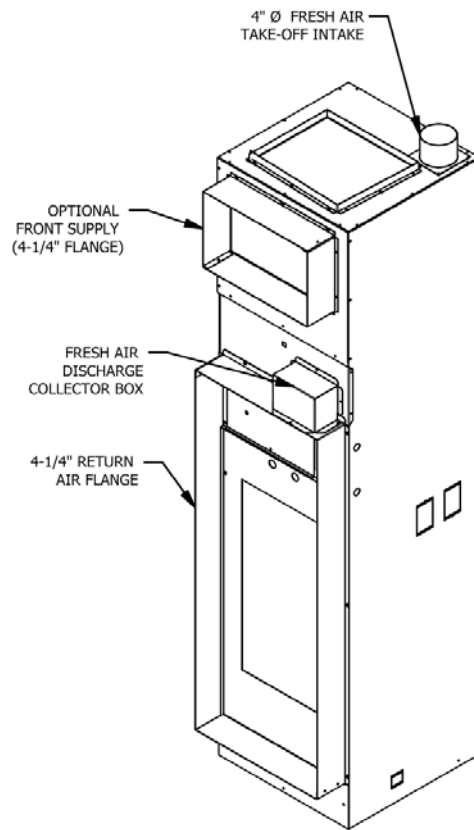



**9. CHASSIS INSTALLATION**

Prior to installation of the refrigeration chassis, and connection to the supply and return risers, the entire water loop system must be flushed and cleaned. See Section 14.



**DO NOT APPLY SEALING TAPE OR PIPE DOPE ON NPSH STYLE FITTINGS!**



Check that female end gasket from the hose is not missing, has no visible damage and free of debris.



**ALWAYS USE A BACK-UP WRENCH WHEN INSTALLING HOSES!**



Protect chassis from physical damage, drywall dust, paint fumes and construction contamination during.

Remove the inner service panel from the cabinet, and inspect the interior compartment for debris.

Locate the supply and return shut-off valves, and verify that the valves are closed. Check to see what type of hose kit fittings were provided with the unit. Unit shipped after June 2013 feature NPSH fittings (straight thread), while previous generation hose kits are NPT type (tapered thread). Refer to previous section 6B for more information.



**HOSES MUST BE HAND TIGHTENED THEN FURTHER TIGHTENED NO MORE THAN 1/4 TURN. DO NOT APPLY EXCESSIVE FORCE!**



**ALWAYS USE A BACK-UP WRENCH WHEN TIGHTENING HOSES TO VALVES! OTHERWISE VALVE SOLDER JOINT MAY FAIL LEADING TO PROPERTY DAMAGE OR SERIOUS INJURY!**

**A. Units with NPSH Valve Connection and Hose Sets:**

NPSH Flexible connection hoses do not require any pipe dope or sealant tape. **DO NOT ADD THREAD SEALANT OR PIPE DOPE TO NPSH FITTINGS.** Connect the hoses to the NPSH fitting on the shut-off valves. Always use a back-up wrench when tightening the hose to the valve fitting. Allow the hoses to hang free inside the cabinet.

Once chassis is slid into place attach the NPSH hoses to the NPSH fittings on the chassis stub outs projecting through the top of the compressor compartment access cover. Always use a back-up wrench to prevent twisting of the copper water piping within the chassis assembly. Refer to the following page for proper chassis installation.

**B. Units with NPT-Style (Tapered Pipe Thread) Valve Connection and Hoses:**

Factory supplied NPT flexible connection hoses come with thread sealing compound pre-applied. **NO ADDITIONAL THREAD SEALING TAPE SHOULD BE REQUIRED.** Connect the hoses to the FPT fitting on the shut-off valves. Always use a back-up wrench when tightening the hose to the valve fitting. Allow the hoses to hang free inside the cabinet.

Slide chassis into place, see following page. J-swivel adapter (supplied with the hose kit), comes with thread sealing compound pre-applied. **NO ADDITIONAL THREAD SEALANT SHOULD BE REQUIRED.** Thread the swivel adapters into the FPT fittings projecting through the top of the compressor compartment access cover. Always use a back-up wrench to prevent twisting of the copper water piping within the chassis assembly.



**To minimize the possibility of damage to the chassis or cabinet, for maximum ease of installation, the use of a two-wheeled dolly is strongly recommended.**



**Do not contact the finned coil face. Damage to the fins will result.**

1. Lift chassis from the front of chassis as shown.



2. Align chassis with the opening of the cabinet. Tilt back sufficiently for the base of the chassis to clear the mounting rails on the cabinet drain pan.



3. Insert chassis midway into the opening of the cabinet. Lower the rear of the chassis until the base of the chassis contacts the formed mounting rails in the cabinet drain pan.



4. Pivot the chassis base on the front edge of the drain pan rails. Before fully inserting chassis – Ensure wiring harness and or water hoses will not be pinched between chassis and cabinet.



5. Slide the chassis into the cabinet until at least  $\frac{3}{4}$  of the depth of the chassis is supported. The chassis should slide easily on the drain pan rails. **Do not apply excessive force!** Ensure that the chassis will not tip forward before removing dolly.



**Before fully inserting chassis, ensure wiring harness and or water hoses will not be pinched.**



**Do not apply excessive force when sliding chassis into cabinet!.**



**To avoid damage from clogged coil surfaces, plugged motor ventilation openings, and potential unit failure, DO NOT operate unit without complete enclosure, supply grille, return air panel and filter in place**

6. Connect hoses to the chassis. Ensure that the hoses will not be pinched once the chassis is slid into place.
7. Check alignment of the chassis in the cabinet. The chassis should be centered in the cabinet opening – without touching the flanges on the sides of the cabinet opening.



8. Complete the electrical connections to the chassis by means of the two quick connect mating plugs. The unit-mounted plug ends are located on the bottom of the control box.
9. Remove the shipping cover from the face of the air-to-refrigerant coil. Install the inner service panel. Check that the foam gasket seal between the panel and the chassis is slightly compressed. If necessary, pull the chassis forward slightly to ensure an adequate seal between the chassis and the service panel.
10. Install the air filter onto the face of the service panel. Slide the filter upward into the top-retaining clip, until the bottom of the filter can be dropped onto the lower clip.
11. Install service panel. If not done already, install the Return Air panel into the drywall opening. Refer to Section 6. Secure the panel into the drywall with six screws.

**10. UNIT START-UP**

**A. Pre-Start-up Checklist**

When the installation is complete and the system is cleaned and flushed, open the supply and return shut-off valves at each unit, refill the system and bleed off all air.

Before energizing the unit, the following system devices must be checked:

- Is the high voltage power supply correct and in accordance with the nameplate ratings?
- Is the field wiring and circuit protection the correct size?
- Is the unit electrically grounded?
- Is the low voltage control wiring correct per the unit wiring diagram?
- Is vibration isolation provided? (unit isolation pad, flexible hoses, etc.)
- Are the low / high-side pressure temperature caps secure and in place?
- Are all the unit access panels secure and in place?
- Is the thermostat in the OFF position?
- Is the water flow established and circulating through all the units?
- Is the ductwork (if required) correctly sized, run, taped, and insulated?
- Does the indoor blower turn freely without rubbing?
- If applicable has glycol fluid been added in the proper mix to prevent freezing in closed system application?
- Are clean, properly sized air filters in place?
- Is the condensate drain pipe firmly secured to both drain riser and drain pan stub?

**B. Initial Unit Start-up**

1. Close disconnect switches on all units to provide line power.



**During installation, testing, servicing, and troubleshooting of this product, it may be necessary to work with live electrical components. Failure to follow all electrical safety precautions when exposed to live electrical components could result in serious injury or death.**

2. Set the thermostat to the highest temperature setting.
3. Set the thermostat system switch to COOL; the fan control switch to AUTO. The compressor should NOT run.
4. Reduce the temperature control setting until the compressor and supply fan are energized. Water temperature leaving the heat exchanger should be warmer than the entering water temperature (approx. 9-12°F). Blower operation should be smooth. Compressor and blower amps should be within the nameplate data

values. The suction line should be cool, with no frost observed in the refrigerant circuit.

5. Turn the thermostat switch to the OFF position. The compressor and fan should stop running, and the reversing valve should de-energize.
6. Leave the unit off for approximately 5 minutes to allow for pressure equalization.
7. Turn the thermostat to the lowest setting.
8. Set the thermostat system switch to the HEAT position. The compressor should NOT run.
9. Adjust the temperature setting upward until the compressor and supply fan are energized. After several minutes, warm air should be detected at the supply register. A water temperature *decrease* of approximately 5-9°F across the heat exchanger should be noted. The blower and compressor operation should be smooth, with no frost observed in the refrigerant circuit.
10. Set the thermostat to maintain the desired space temperature.
11. Check all water connections for any leaks, including condensate drain hose connections.

**C. System Loop Temperature**

Loop temperatures affect unit performance, power consumption (efficiency), maintenance and reliability, and noise levels. High entering water temperatures (EWT) in cooling mode above rated conditions of 86°F EWT will increase power consumption and increase compressor noise levels. Sustained operation above 100°F EWT may increase maintenance costs and increased compressor noise may affect occupancy comfort. Unit is designed to operate up to 110°F EWT for intermittent periods when system loop temperatures become elevated under high load conditions. It is not recommended to set system loop temperatures at 110°F in case of high load conditions cause supply loop temperatures to exceed 110°F EWT. Unit sound performance may be negatively impacted at high EWT.

When in heating season maximum operating loop temperature is 90°F EWT. It is recommended to maintain system loop temperatures at or above rated conditions of 68°F EWT for optimal unit performance. If system loop temperatures are low where freezing the coaxial is possible, system loop must contain a glycol fluid mixture that is adequate to prevent freezing. Minimum loop temperature with glycol mixture is 20°F EWT. Lower loop temperatures will result in lower efficiency and heating capacity.



**High system loop temperatures may negatively affect unit performance, efficiency, maintenance and reliability, and noise levels.**

Operating Limits

	COOLING	HEATING
MIN. ENTERING WATER	30°F	20°F
MAX. ENTERING WATER	110°F	90°F

**11. FAN SPEED ADJUSTMENT**

Multi-speed direct drive motors are used in all units as standard. Although the PSC fan motors have a minimum of three selectable speeds, and EC motors have five speeds, only two speeds are recommended and selected for use.

Optional ECM increases operating efficiency by consuming fewer watts than standard PSC motors. Motors are factory programmed and cannot be re-programmed in the field. Each motor contains 5 low voltage speed taps – two speed taps are used as standard.

Blower speed taps are factory set for optimum heating and cooling airflow ranges. Refer to Table 5 for factory blower speed settings, and minimum operating airflow.

Located on the electrical box cover, a unit mounted 2-speed fan switch allows fan speed switching from LOW and HIGH fan speeds to meet site conditions such as increased ductwork static pressure, or the use of higher efficient filters.

Installed system must be test run to ensure operation with sufficient heating and cooling airflow. Excessive ductwork static pressure will result in an improper volume of airflow. High airflow volumes will result in elevated noise levels and may affect occupancy comfort.



**Operating unit below the minimum airflow may result poor heating / cooling performance and periodic unit lockout.**



**LOCK ALL ELECTRICAL POWER SUPPLY SWITCHES IN THE OFF POSITION BEFORE SERVICING THE UNIT. FAILURE TO DISCONNECT POWER SUPPLY MAY RESULT IN ELECTRICAL SHOCK OR EVEN DEATH.**

**TABLE 5 – Fan Tables**

**PSC Standard Blower Performance (CFM)**

Unit Size	Motor Speed	Rated CFM	Min. CFM	External Static Pressure (in w.g.)												
				0	0.05	0.1	0.15	0.2	0.25	0.3	0.35	0.4	0.45	0.5		
09	HIGH	340	220	340	330	320	310	300	285	270	255	240	225	-		
	LOW			255	250	240	230	220	210	-	-	-	-	-		
12	HIGH	430	290	445	435	425	415	400	385	370	355	340	320	295		
	LOW			350	345	335	325	315	305	290	-	-	-	-		
15	HIGH	550	335	580	570	560	550	535	520	505	485	465	445	425		
	LOW			385	380	375	370	365	355	345	335	-	-	-		
18	HIGH	685	430	700	690	675	660	635	615	595	575	550	525	495		
	LOW			450	445	440	435	430	425	-	-	-	-	-		
24	HIGH	850	575	880	855	835	815	795	770	740	710	680	650	615		
	LOW			715	710	705	690	670	650	630	605	580	-	-		
30	HIGH	1075	700	1115	1100	1075	1050	1020	990	960	930	895	850	800		
	LOW			965	960	950	935	915	895	870	840	810	780	745		
36	HIGH	1220	840	1230	1200	1170	1140	1110	1075	1040	1000	960	915	870		
	LOW			1115	1100	1075	1050	1020	990	960	930	895	855	805		

**PSC High Static Blower Performance (CFM)**

Unit Size	Motor Speed	Rated CFM	Min. CFM	External Static Pressure (in w.g.)																
				0	0.05	0.1	0.15	0.2	0.25	0.3	0.35	0.4	0.45	0.5	0.55	0.6	0.65	0.7	0.75	0.8
09	HIGH	340	220	375	370	360	350	340	330	315	300	285	265	245	220	-	-	-	-	-
	LOW			330	320	310	300	290	280	270	255	240	225	-	-	-	-	-	-	-
12	HIGH	430	290	485	475	465	455	440	425	410	395	380	360	340	315	-	-	-	-	-
	LOW			390	385	380	370	360	350	335	320	305	-	-	-	-	-	-	-	-
15	HIGH	550	335	665	650	635	615	595	575	555	540	520	500	475	450	420	395	370	340	-
	LOW			580	570	560	550	535	520	505	485	465	445	425	400	375	350	-	-	-
18	HIGH	685	430	750	735	715	695	675	655	630	605	580	555	525	495	465	435	-	-	-
	LOW			670	655	640	625	605	585	560	535	510	485	460	435	-	-	-	-	-
24	HIGH	850	575	990	970	950	930	910	890	865	845	820	795	770	740	710	680	650	615	575
	LOW			795	785	775	760	745	730	715	695	675	655	630	605	580	-	-	-	-
30	HIGH	1075	700	1180	1170	1160	1145	1130	1110	1090	1070	1050	1025	1000	970	940	910	875	840	800
	LOW			985	980	975	970	960	950	940	935	920	905	895	875	850	825	795	765	730
36	HIGH	1220	840	1340	1320	1295	1270	1245	1220	1190	1160	1130	1100	1070	1040	1010	980	945	910	870
	LOW			1180	1170	1160	1145	1130	1110	1090	1070	1050	1025	1000	970	940	910	875	840	800

**ECM Standard Blower Performance (CFM)**

Unit Size	Motor Speed	ECM TAP#	Rated CFM	Min. CFM	External Static Pressure (in w.g.)										
					0	0.05	0.1	0.15	0.2	0.25	0.3	0.35	0.4	0.45	0.5
09	HIGH	2	340	180	342	317	292	276	259	247	236	228	220	214	207
	LOW	1			278	252	226	212	198	189	180	-	-	-	-
12	HIGH	4	430	236	463	431	399	378	356	340	324	317	310	299	289
	LOW	2			342	317	292	276	259	247	236	-	-	-	-
15	HIGH	2	550	268	600	567	534	500	466	445	424	396	367	340	312
	LOW	1			495	447	399	372	346	307	268	-	-	-	-
18	HIGH	4	685	396	760	726	693	667	642	615	587	574	561	529	497
	LOW	2			600	567	534	500	466	445	424	396	-	-	-
24	HIGH	4	850	574	891	863	835	809	784	757	730	689	648	601	554
	LOW	2			760	726	693	667	642	615	587	574	-	-	-
30	HIGH	3	1075	718	1131	1105	1079	1058	1037	1016	994	972	949	934	918
	LOW	1			918	894	870	852	835	808	781	762	743	718	-
36	HIGH	4	1220	861	1265	1235	1206	1184	1163	1141	1118	1085	1051	1008	965
	LOW	2			1065	1037	1009	987	965	949	934	910	886	874	861

**ECM High Static Blower Performance (CFM)**

Unit Size	Motor Speed	ECM TAP#	Rated CFM	Min. CFM	External Static Pressure (in w.g.)															
					0	0.05	0.1	0.15	0.2	0.25	0.3	0.35	0.4	0.45	0.5	0.55	0.6	0.65	0.7	0.75
09	HIGH	3	340	220	411	382	354	334	315	300	286	279	272	263	254	242	231	220	-	-
	LOW	2			342	317	292	276	259	247	236	228	220	-	-	-	-	-	-	-
12	HIGH	5	430	290	554	529	504	477	451	430	408	393	378	360	341	330	319	300	-	-
	LOW	4			463	431	399	378	356	340	324	317	310	299	290	-	-	-	-	-
15	HIGH	3	550	312	659	623	587	564	541	511	482	462	441	419	397	372	346	320	-	-
	LOW	2			600	567	534	500	466	445	424	396	367	340	312	-	-	-	-	-
18	HIGH	5	685	408	891	863	835	809	784	757	730	689	648	601	554	518	482	446	408	-
	LOW	4			760	726	693	667	642	615	587	574	561	529	497	469	441	412	-	-
24	HIGH	5	850	571	1002	971	940	912	883	854	826	800	774	749	724	698	671	643	615	586
	LOW	3			866	827	789	762	735	708	682	659	636	612	587	571	-	-	-	-
30	HIGH	4	1075	701	1265	1235	1206	1184	1163	1141	1118	1085	1051	1008	965	913	861	808	756	701
	LOW	2			1065	1037	1009	987	965	949	934	910	886	874	861	839	818	-	-	-
36	HIGH	5	1220	840	1462	1418	1375	1331	1287	1241	1194	1153	1112	1053	994	964	934	903	872	840
	LOW	4			1265	1235	1206	1184	1163	1141	1118	1085	1051	1008	965	913	861	-	-	-

**ECM Blower Performance – All Speed Taps (CFM)**

Unit Size	ECM TAP#	Rated CFM	Min. CFM	External Static Pressure (in w.g.)																
				0	0.05	0.1	0.15	0.2	0.25	0.3	0.35	0.4	0.45	0.5	0.55	0.6	0.65	0.7	0.75	
09	1	340	180	278	252	226	212	198	189	180	-	-	-	-	-	-	-	-	-	
	2			342	317	292	276	259	247	236	228	220	214	207	-	-	-	-	-	
	3			411	382	354	334	315	300	286	279	272	263	254	242	231	220	-	-	
	4			463	431	399	378	356	340	324	317	310	299	290	-	-	-	-	-	
	5			554	529	504	477	451	430	408	393	378	360	341	330	319	300	-	-	
12	1	430	236	278	252	226	212	198	189	180	-	-	-	-	-	-	-	-		
	2			342	317	292	276	259	247	236	-	-	-	-	-	-	-	-		
	3			411	382	354	334	315	300	286	279	272	263	254	242	231	220	-	-	
	4			463	431	399	378	356	340	324	317	310	299	289	-	-	-	-	-	
	5			554	529	504	477	451	430	408	393	378	360	341	330	319	300	-	-	
15	1	550	268	495	447	399	372	346	307	268	-	-	-	-	-	-	-	-		
	2			600	567	534	500	466	445	424	396	367	340	312	-	-	-	-		
	3			659	623	587	564	541	511	482	462	441	419	397	372	346	320	-	-	
	4			760	726	693	667	642	615	587	574	561	529	497	469	441	412	-	-	
	5			891	863	835	809	784	757	730	689	648	601	554	518	482	446	408	-	-
18	1	685	396	495	447	399	372	346	307	268	-	-	-	-	-	-	-	-		
	2			600	567	534	500	466	445	424	396	367	340	312	-	-	-	-		
	3			659	623	587	564	541	511	482	462	441	419	397	372	346	320	-	-	
	4			760	726	693	667	642	615	587	574	561	529	497	469	441	412	-	-	
	5			891	863	835	809	784	757	730	689	648	601	554	518	482	446	408	-	-
24	1	850	574	659	623	587	564	541	511	482	462	441	419	397	372	346	320	-	-	
	2			760	726	693	667	642	615	587	574	-	-	-	-	-	-	-		
	3			866	827	789	762	735	708	682	659	636	612	587	571	-	-	-	-	
	4			891	863	835	809	784	757	730	689	648	601	554	518	482	446	408	-	-
	5			1002	971	940	912	883	854	826	800	774	749	724	698	671	643	615	586	-
30	1	1075	718	918	894	870	852	835	808	781	762	743	718	-	-	-	-	-		
	2			1065	1037	1009	987	965	949	934	910	886	874	861	-	-	-	-		
	3			1131	1105	1079	1058	1037	1016	994	972	949	934	918	-	-	-	-		
	4			1265	1235	1206	1184	1163	1141	1118	1085	1051	1008	965	913	861	808	756	701	
	5			1462	1418	1375	1331	1287	1241	1194	1153	1112	1053	994	964	934	903	872	840	
36	1	1220	861	918	894	870	852	835	808	781	762	743	718	-	-	-	-	-		
	2			1065	1037	1009	987	965	949	934	910	886	874	861	-	-	-	-		
	3			1131	1105	1079	1058	1037	1016	994	972	949	934	918	-	-	-	-		
	4			1265	1235	1206	1184	1163	1141	1118	1085	1051	1008	965	913	861	808	756	701	
	5			1462	1418	1375	1331	1287	1241	1194	1153	1112	1053	994	964	934	903	872	840	

Note: All airflow ratings are at lowest voltage rating of dual rating (i.e. 208 volt).  
Airflow ratings include resistance of wet coil and clean air filters.

## 12. MAINTENANCE

Maintenance on the unit is simplified with the following preventive suggestions:

1. Visually inspect unit at least once a month. Special attention should be paid to hose assemblies. Note any signs of hose deterioration or cracking; attend to any indication of minor leakage immediately.
2. Filter maintenance must be performed to ensure proper operation of the equipment. Inspect filters at least every three months, and replace when visible dirt build-up is evident.



**To avoid fouled machinery and extensive unit clean up, DO NOT operate units without filters in place, or use the unit as a temporary cooling/heating source during construction.**

3. Inspect condensate drain pan for algae growth and mineral build-up every three months. Excessive algae or mineral deposits in the drain pan or drain line can result in condensate overflow and unpleasant mildew odors.
4. Check fan motor and blower assembly annually. All units employ permanently lubricated fan motors. DO NOT OIL FAN MOTORS. Vacuum any accumulation of dirt from motor ventilation slots and the blower wheel.
5. Check the contactors and relays within the control panel annually. Inspect for any visible signs of overheated contacts or temperature damage to wiring. Check terminals for tightness.
6. Conduct an amperage check annually on the compressor and fan motor. Higher amperage draw than nameplate values (more than 10%) may indicate heat exchanger fouling, low water flow, or premature physical motor failure.
7. Inspect air-to-refrigerant heat exchanger surface at least once a year. A dirty or partially clogged coil can significantly reduce operating capacity, and can result in serious equipment problems. If the coils appear dirty, clean them using mild detergent or a commercial coil-cleaning agent.
8. Inspect hoses, valves and connections for water leaks. For hose connection leaks inspect rubber hose gaskets and replace as required.

### Safety Control Reset

All VSCS heat pumps are furnished with a high-pressure protection switch, a low-pressure control switch, low water temperature protection switch and condensate overflow switch to prevent compressor operation during abnormal conditions.

If either of these safety devices is activated a lockout relay circuit is engaged, which interrupts heating and cooling operation, even though the control contacts may have automatically re-closed.

This microprocessor driven lockout circuit must be manually reset. Reset is accomplished by moving the thermostat control (system) switch to the OFF position momentarily, then back to the HEAT, or COOL (or AUTO) position.

The lockout circuit may also be reset by opening and closing the unit mounted disconnect switch.

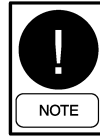

**If the unit must be reset more than twice on consecutive operating cycles, check the unit for a dirty filter, abnormal entering water temperature, inadequate or excessive water flow, or refrigerant circuit malfunction. If the unit continues to cutout, contact a trained service technician.**

## 13. UNIT CONTROLS

The control system microprocessor board is specifically designed for water source heat pump operation. The control system interfaces with a conventional type thermostat.

- A. Unit shall be complete with self-contained low-voltage control circuit
- B. Unit shall incorporate a lockout circuit which provides reset capability from a hard lock-out at the space thermostat or base unit, should any of the following standard safety devices trip and shut off compressor.
  - a. Loss-of-charge/Low-pressure switch
  - b. High-pressure switch
  - c. Freeze-protection thermostat, unit shutdown on low water temperature.
  - d. Condensate Overflow protection switch
- C. Unit shall operate with conventional thermostat designs and have a low voltage terminal strip for easy hook-up.
- D. Unit control board shall have on-board diagnostics and fault code display.
- E. Standard controls shall include anti-short cycle and low voltage protection
- F. Control board shall monitor each refrigerant safety switch independently.
- G. Control board shall have random start feature
- H. Control board shall retain last 5 fault codes in non volatile memory which will not be lost in the event of a power loss.

### Sequence of Operation

The room t-stat makes a circuit between "R" & "Y1" for cooling.

The call is passed to the unit micro processor control, which then determines whether the requested operation is available and, if so, which components to energize.

For the heating, the room t-stat makes a circuit between "R" & "W1". The micro processor control energizes the compressor and fan allowing the unit to run in heating mode.

If at any time a call for both heating and cooling are present, the heating operation will be performed. If operating, the cooling system is halted as with a completion of a call for cooling. Heating always takes priority.

### Continuous Blower

With the room t-stat fan switch set to "AUTO" and the system switch set to either the "AUTO" or "HEAT" settings, the blower is energized whenever a cooling or heating operation is requested. The blower is energized after any specified delay associated with the operation.

When energized, the indoor blower has a minimum run time of 30 seconds. Additionally, the indoor blower has a delay of 10 seconds between operations.

When the room t-stat calls for cooling, the low-voltage control circuit from "R" to "Y1" and "G" is completed. The compressor and fan motor are energized. After completing the specified fan on delay for cooling, the micro processor control will energize the blower motor.

Once the room t-stat has been satisfied, it will de-energize "Y1". If the compressor has satisfied its minimum run time, the compressor and fan de-energize. Otherwise, the unit operates the cooling system until the minimum run time for the compressor has been completed. After the compressor de-energizes, the blower is stopped following the elapse of the fan off delay for cooling.

To be available, a compressor must not be locked-out due to a high pressure switch; low pressure switch; condensate overflow switch; freeze-stat trip and the anti-short cycle delay (ASCD) must have elapsed.

#### Operation Errors

Each refrigerant system is monitored for operation outside of the intended parameters. Errors are handled as described below. All system errors override minimum run times for compressors.

#### **High-Pressure Limit Switch**

If a high pressure limit switch opens. The micro processor control de-energizes the compressor, initiates the ASCD (Anti-short cycle delay), and stops the unit fans (soft lock-out). If a call for cooling or heating is still present at the conclusion of the ASCD, the micro processor control will re-energize the compressor and unit fan.

Should a high pressure switch open three times within two hours of operation, the micro processor control will permanently lock –out the system compressor, requiring a manual reset of the system (enter a hard lock-out), by de-energizing the 24 volt power to unit, or turning the room t-stat to the "OFF" position then back to either heating or cooling as required. The micro processor control will flash a fault code indicating the high pressure lock-out. (See attached table).

#### **Low Pressure Limit Switch**

The low pressure limit switch is not monitored during the initial 30 seconds of compressor operation. For the following 30 seconds, the microprocessor control will monitor the low pressure switch to ensure it closes. If the low pressure switch fails to close after the 30 second monitoring phase, the micro processor control will de-energize the compressor, initiate the ASCD, and stop the fan (soft lock-out).

Once the low–pressure switch has been proven (closed during the 30 second monitor period described above), the microprocessor control will monitor the low pressure switch for any openings. If the low–pressure switch opens for greater than 5 seconds, the micro processor control will de-energize the compressor, initiate the ASCD, and stop the compressor (soft lock-out).

If the call for cooling is still present at the conclusion of the ASCD, the micro processor control will re-energize the compressor.

Should a low pressure switch open three times within one hour of operation, the microprocessor control board will lock-out the compressor (enter into a hard lock-out) and flash a fault code (see attached table).

#### **Freeze-stat**

If a freeze-stat opens, the micro processor control will de-energize the compressor, and initiate the ASCD. If a call for cooling or heating is still present at the conclusion of the ASCD, the micro processor control will re-energize the halted compressor.

#### **Condensate Overflow Switch**

A Condensate Overflow fault occurs if the Condensate Overflow switch opens continuously for 30 seconds. The compressor is shutdown regardless of Minimum Run Time and alarm 15 is set. Fan continues operating in its current state.

The control logs the first incident per compressor request. Lockout occurs on the second fault occurrence within a request cycle, requiring reset or power cycling. If the compressor request is removed, the fault occurrence counter is reset to zero. When lockouts are removed, the alarm is reset.

#### Safety Controls

The micro processor control monitors the following inputs:

1. A suction line freeze-stat to protect against low leaving water temperatures (opens at 34F and resets at 48F.)
2. A high pressure switch to protect against excessive discharge pressures (opens at 600 psig +/- 25 psig).
3. A low pressure switch to protect against loss of refrigerant charge (opens at 55psig +/- 5 psig).
4. A Condensate Overflow Switch to protect against condensate overflow

#### Coaxial Freeze Protection Set Point

The unit allows for field selection of the coaxial freeze protection set point. Unit utilizes a suction line freeze-stat factory set for compressor lock-out when leaving water temperature drops below 35F (resets at 48F). To lower the set point for low temp heating applications with an adequate water-antifreeze solution, unplug freeze-stat sensor, located at P6 on the microprocessor control board and plug in the (pink) jumper attached to existing harness. By installing the jumper, the freeze-stat is bypassed allowing for heating operation with leaving water temperatures below 35F. Use jumper only in low water applications with adequate antifreeze protection, otherwise damage can occur.

#### Random Start

Random start function, upon power up, will impose time delay of 4 minutes plus a random delay of 1 to 64 seconds. The random number generator seed is determined by a fixed seed programmed at the factory combined with the serial number, model number, and the hours of compressor run time of the unit.

#### Compressor Protection

In addition to the external pressure switches, the compressor also has inherent (internal) protection. If there is an abnormal temperature rise in a compressor, the protector will open to shut down the compressor. The micro processor control incorporates features to minimize compressor wear and damage. An anti-short cycle delay (ASCD) is utilized to prevent operation of a compressor too soon after its previous run. Additionally, a minimum run time is imposed any time a compressor is energized. The ASCD is initiated on unit start-up and on any compressor reset or lockout.

#### Microprocessor Control Unit Flash Codes

Various flash codes are utilized by the microprocessor control to aid in troubleshooting. Flash codes are distinguished by the short on and off cycle used (approximately 200ms on and 200ms off). To show normal operation, the control boards flash a 1 second on, 1 second off "heart beat" during normal operation. This is to verify that the micro processor is functioning correctly. Do not confuse this with an error flash code. To prevent confusion, a 1-flash, fault code is not used. See Table 6 for list of all flash codes.

Current alarms or active restrictions are flashed on the microprocessor control LED.

1. Last Error – When this button is pressed and released one time within five seconds, it flashes the last five fault codes on the board's LED. The most recent alarm is shown first and the oldest alarm is shown last.
2. Test Reset – When this button is pressed and released one time with five seconds, any anti-anti-short cycle delay (ASCD) is bypassed for one cycle.
3. Comm Set UP – If the board is to be networked with other units, this button is used to set the network address.

The first time the button is pressed within five seconds, it scans the bus, and then assigns itself the first available address, (starts at 2).It then flashes that address one time.

Pressing the button two times within five seconds causes the control to flash the address.

#### Communication

The communication protocol is MODBUS using the RTU method of packet framing at 19200-baud rate.

**TABLE 6 – Flash Codes**

Flash Codes	Description
On Steady	Control Failure – Replace Control
Heart Beat	Normal Operation
2 Flashes	Control Waiting on ASCD <sup>1</sup> (Anti-Short Cycle Delay)
3 Flashes	HPS1 – Compressor Lock out
5 Flashes	LPS1 – Compressor Lock out
13 Flashes	Compressor Held OFF due to Low Voltage <sup>1</sup>
14 Flashes	EEPROM Storage Failure (Control Failure)
15 Flashes	Condensate Overflow Switch – Compressor Lock out
16 Flashes	Coaxial Freeze Thermostat – Compressor Lock out

1. These flash codes do not represent alarms.



#### 14. SYSTEM FLUSHING AND CLEANING

After the piping system is complete, and prior to connection of the refrigeration chassis, the risers should be flushed and cleaned to ensure proper start-up and continued efficient operation of the system.

1. Ensure that the supply and return riser shut-off valves are closed at each unit.
2. Using flexible hoses or piping, connect the supply and return stub-outs in the unit located at the end of the riser run(s). If the building has more than 10 floors, connect the supply and return stub-outs in the last two units to divide the water flow and reduce pressure drop at the pump. (See Figure below)
3. Open the shut-off valves in the units that have had the supply and return risers inter-connected.
4. The water circulation system should be filled with clean water using the make-up water supply. The air vents should be open during initial filling (Do not allow the system to overflow).
5. With the air vents closed, start the circulating pump and then crack each air vent to ensure that all air is bled from the system. (*Make-up water must be available in sufficient volume to replace the volume occupied by the air that is bled off.*)
6. When all air is vented, and the water is circulating under pressure, the entire system should be checked for leaks. Make any repairs as required.
7. Set the loop temperature controls to raise the temperature to approximately 85°F. Perform a visual check for any leaks that may have occurred due to the increased heat. Repair as required.
8. Open the drain at the lowest point in the system (make-up water flow rate must be equal to rate of drain bleed). Continue to bleed system until water leaving the drain is clear, but not less than 2 hours.
9. Completely drain the piping system.

After the initial Flushing, the system should be chemically cleaned. The procedure for re-filling the system, and circulating the cleaning solution, is the repeat of the above flushing method.

The services of a professional water treatment company are recommended with regards to the type of solution to be used, and the duration of the cleaning application.

Once the cleaning process is complete, shut off the circulating pump and completely drain the system. Refill the system with clean water in preparation for connection of the refrigeration chassis, and system start-up.

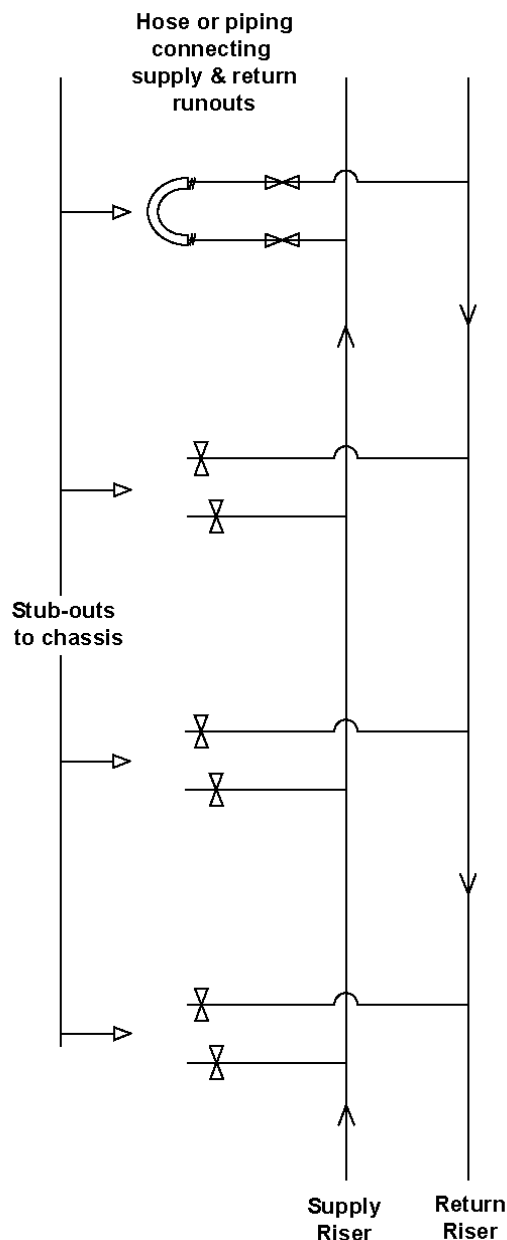

**It is strongly recommended a professional water treatment company is used to perform on-going maintenance of water loop including chemical analysis, and if necessary flushing. The water loop testing should be performed at intervals recommended by the professional water treatment consultant. It is up to the customer to carry out adequate water loop maintenance over the lifespan of the units otherwise damage to the units may occur.**

APPENDIX:

PSC MOTOR WIRING DIAGRAM

Mar 10, 2014

VSCS SERIES; 208-230V/1Ph/60Hz  
265V/1Ph/60Hz

**LEGEND:**

- S2 - FAN SPEED SWITCH
- C1 - COMPRESSOR CONTACTOR
- TRF - 24V CONTROL TRANSFORMER
- COMP - COMPRESSOR MOTOR
- EFM - EVAP. FAN MOTOR
- Rsv - REVERSING VALVE RELAY
- R2 - BLOWER RELAY
- CFT - COAXIAL FREEZE THERMOSTAT
- HPC - HIGH PRESSURE SWITCH
- LPC - LOW PRESSURE SWITCH
- RC - RUN CAPACITOR
- SV - REVERSING VALVE COIL
- COS - CONDENSATE OVERFLOW SWITCH
- MB - MICROPROCESSOR BOARD
- F6 - TRANSFORMER SECONDARY FUSE

**OPTIONAL:**

- TB1 - LINE VOLTAGE TERMINAL BLOCK
- MV - MOTORIZED VALVE
- S1 - LINE VOLTAGE DISCONNECT
- F1 - LINE VOLTAGE FUSES
- WP - WATER PUMP

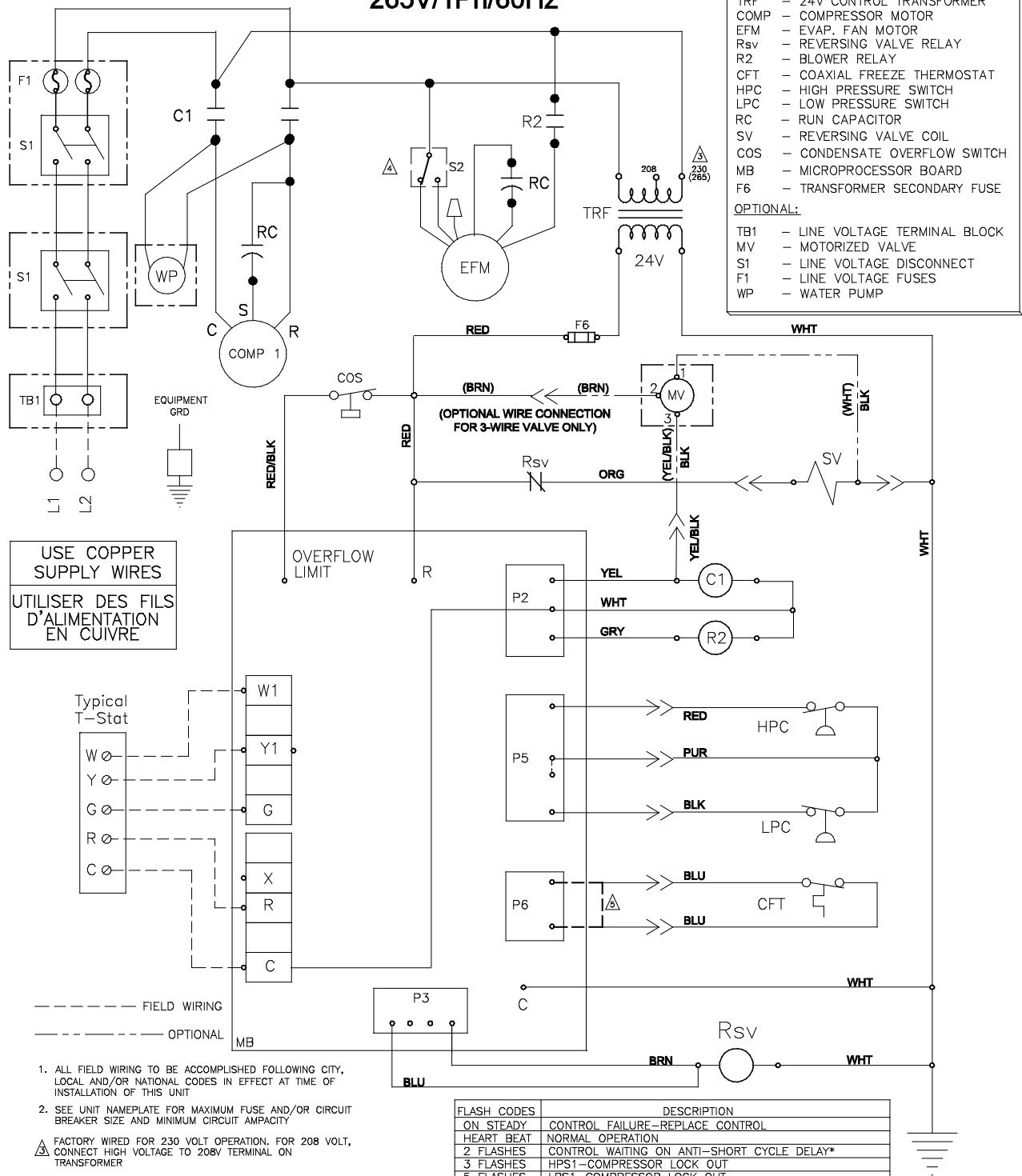

USE COPPER SUPPLY WIRES  
UTILISER DES FILS D'ALIMENTATION EN CUIVRE

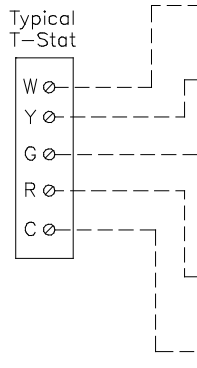

--- FIELD WIRING  
- - - - - OPTIONAL

1. ALL FIELD WIRING TO BE ACCOMPLISHED FOLLOWING CITY, LOCAL AND/OR NATIONAL CODES IN EFFECT AT TIME OF INSTALLATION OF THIS UNIT
  2. SEE UNIT NAMEPLATE FOR MAXIMUM FUSE AND/OR CIRCUIT BREAKER SIZE AND MINIMUM CIRCUIT AMPACITY
- ⚠ FACTORY WIRED FOR 230 VOLT OPERATION. FOR 208 VOLT, CONNECT HIGH VOLTAGE TO 208V TERMINAL ON TRANSFORMER
  - ⚠ REFER TO INSTALLATION MANUAL FOR UNIT-SPECIFIC FACTORY BLOWER SPEED CONNECTIONS
  - ⚠ FOR LOW TEMPERATURE OPERATION, DISCONNECT CFT, AND INSTALL JUMPER PLUG.

FLASH CODES	DESCRIPTION
ON STEADY	CONTROL FAILURE—REPLACE CONTROL
HEART BEAT	NORMAL OPERATION
2 FLASHES	CONTROL WAITING ON ANTI—SHORT CYCLE DELAY*
3 FLASHES	HPS1—COMPRESSOR LOCK OUT
5 FLASHES	LPS1—COMPRESSOR LOCK OUT
13 FLASHES	COMPRESSOR HELD OFF DUE TO LOW VOLTAGE*
14 FLASHES	EEPROM STORAGE FAILURE (CONTROL FAILURE)
15 FLASHES	CONDENSATE OVERFLOW SWITCH—COMPRESSOR LOCK OUT
16 FLASHES	COAXIAL FREEZE THERMOSTAT—COMPRESSOR LOCK OUT

\*THESE CODES DO NOT REPRESENT ALARMS.

STK-553-WP

ECM WIRING DIAGRAM

VSCS SERIES w/ ECM MOTOR  
208-230V, 265V/1Ph/60Hz

March 10, 2014

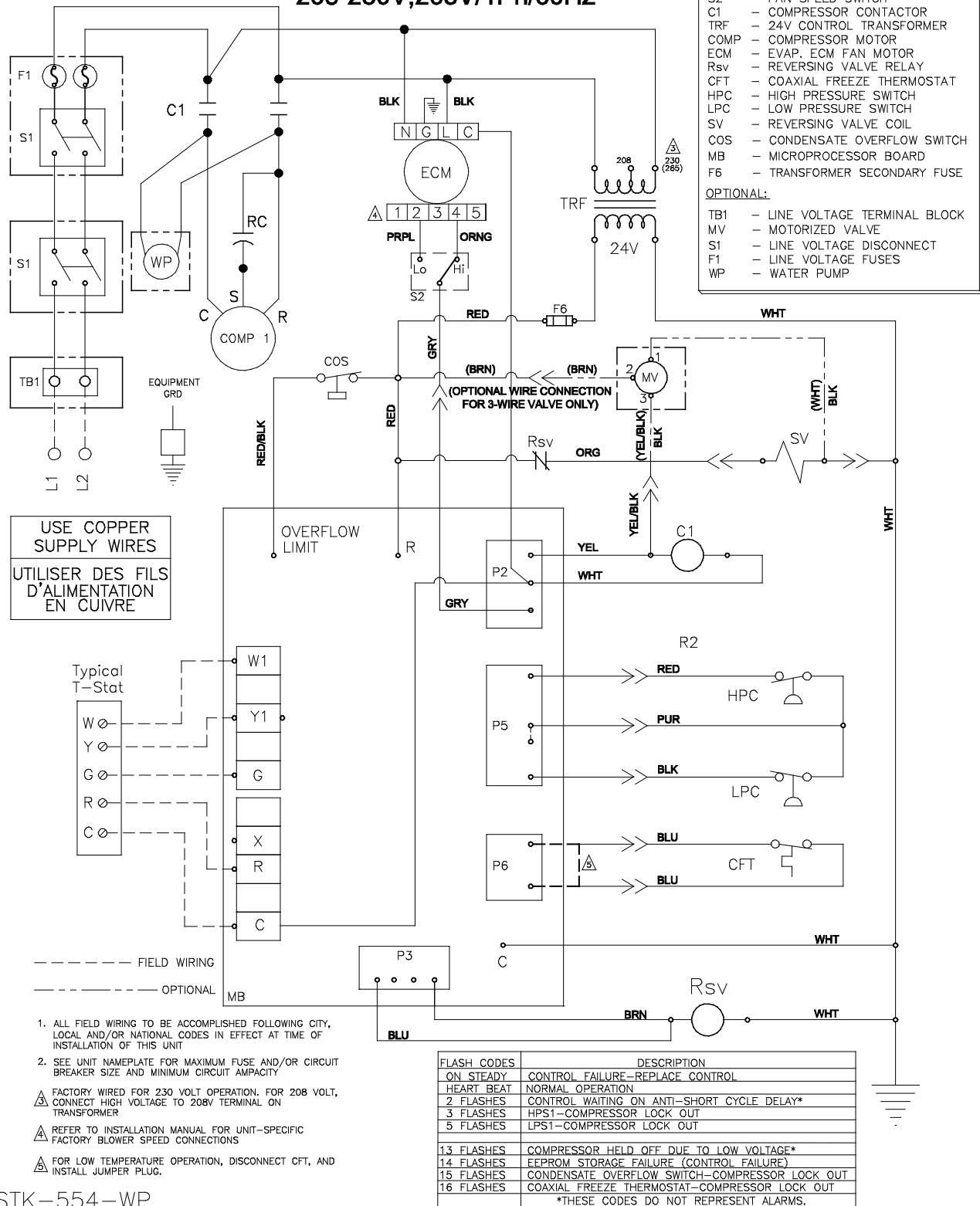

USE COPPER SUPPLY WIRES  
UTILISER DES FILS D'ALIMENTATION EN CUIVRE

----- FIELD WIRING  
----- OPTIONAL

1. ALL FIELD WIRING TO BE ACCOMPLISHED FOLLOWING CITY, LOCAL AND/OR NATIONAL CODES IN EFFECT AT TIME OF INSTALLATION OF THIS UNIT
  2. SEE UNIT NAMEPLATE FOR MAXIMUM FUSE AND/OR CIRCUIT BREAKER SIZE AND MINIMUM CIRCUIT AMPACITY
- ▲ FACTORY WIRED FOR 230 VOLT OPERATION. FOR 208 VOLT, CONNECT HIGH VOLTAGE TO 208V TERMINAL ON TRANSFORMER
- ▲ REFER TO INSTALLATION MANUAL FOR UNIT-SPECIFIC FACTORY BLOWER SPEED CONNECTIONS
- ▲ FOR LOW TEMPERATURE OPERATION, DISCONNECT CFT, AND INSTALL JUMPER PLUG.

STK-554-WP

CONTINUOUS FAN WITH ECM WIRING DIAGRAM

VSCS SERIES w/ ECM MOTOR; 208-230V/1Ph/60Hz

OCT 2014

265V/1Ph/60Hz

**LEGEND:**  
 S2 - FAN SPEED SWITCH  
 C1 - COMPRESSOR CONTACTOR  
 TRF - 24V CONTROL TRANSFORMER  
 COMP - COMPRESSOR MOTOR  
 ECM - EVAP. ECM FAN MOTOR  
 Rsv - REVERSING VALVE RELAY  
 CFT - COAXIAL FREEZE THERMOSTAT  
 HPC - HIGH PRESSURE SWITCH  
 LPC - LOW PRESSURE SWITCH  
 SV - REVERSING VALVE COIL  
 COS - CONDENSATE OVERFLOW SWITCH  
 MB - MICROPROCESSOR BOARD  
 F6 - TRANSFORMER SECONDARY FUSE

**OPTIONAL:**  
 TB1 - LINE VOLTAGE TERMINAL BLOCK  
 MV - MOTORIZED VALVE  
 S1 - LINE VOLTAGE DISCONNECT  
 F1 - LINE VOLTAGE FUSES  
 WP - WATER PUMP

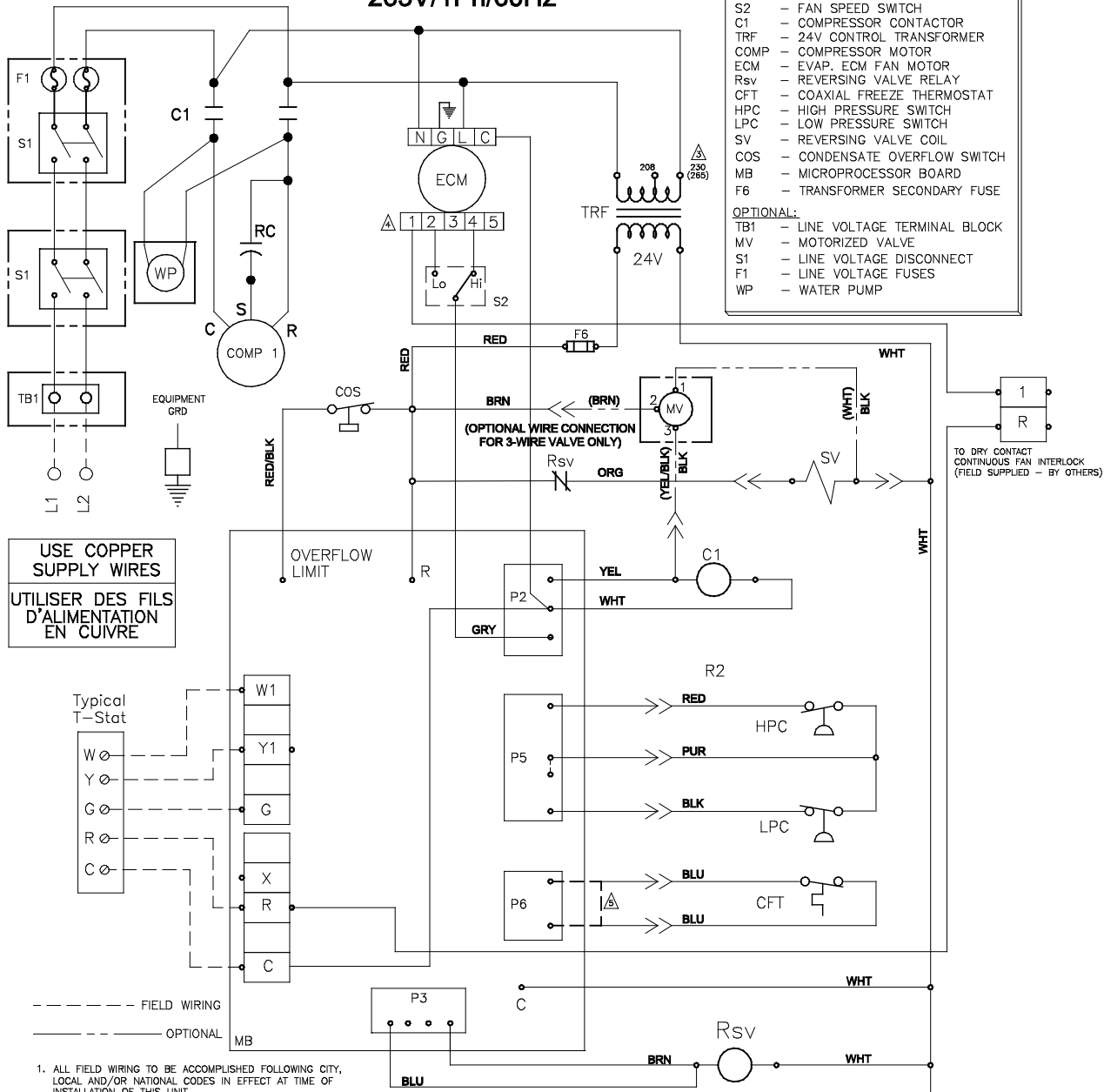

FLASH CODES	DESCRIPTION
ON STEADY	CONTROL FAILURE-REPLACE CONTROL
HEART BEAT	NORMAL OPERATION
2 FLASHES	CONTROL WAITING ON ANTI-SHORT CYCLE DELAY*
3 FLASHES	HPS1-COMPRESSOR LOCK OUT
5 FLASHES	LPS1-COMPRESSOR LOCK OUT
13 FLASHES	COMPRESSOR HELD OFF DUE TO LOW VOLTAGE*
14 FLASHES	EEPROM STORAGE FAILURE (CONTROL FAILURE)
15 FLASHES	CONDENSATE OVERFLOW SWITCH-COMPRESSOR LOCK OUT
16 FLASHES	COAXIAL FREEZE THERMOSTAT-COMPRESSOR LOCK OUT

\*THESE CODES DO NOT REPRESENT ALARMS.

STK-554CF

MOTORIZED DAMPER ECM WIRING DIAGRAM

VSCS SERIES w/ ECM MOTOR; 208-230V/1Ph/60Hz  
265V/1Ph/60Hz

OCT 2014

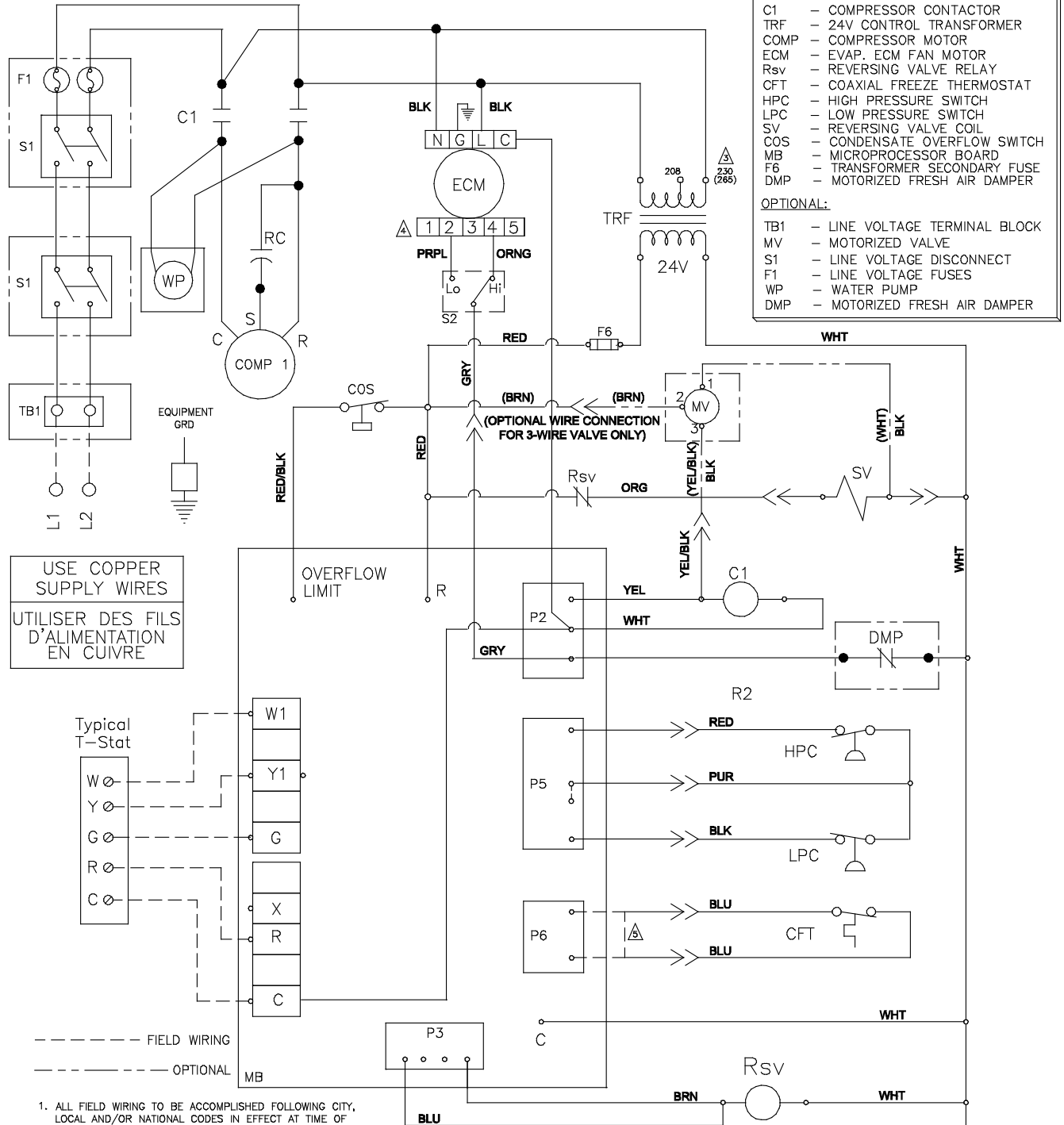

USE COPPER SUPPLY WIRES  
UTILISER DES FILS D'ALIMENTATION EN CUIVRE

Typical T-Stat

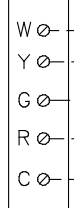

--- FIELD WIRING  
- - - - - OPTIONAL

1. ALL FIELD WIRING TO BE ACCOMPLISHED FOLLOWING CITY, LOCAL AND/OR NATIONAL CODES IN EFFECT AT TIME OF INSTALLATION OF THIS UNIT
2. SEE UNIT NAMEPLATE FOR MAXIMUM FUSE AND/OR CIRCUIT BREAKER SIZE AND MINIMUM CIRCUIT AMPACITY

⚠ FACTORY WIRED FOR 230 VOLT OPERATION. FOR 208 VOLT, CONNECT HIGH VOLTAGE TO 208V TERMINAL ON TRANSFORMER

⚠ REFER TO INSTALLATION MANUAL FOR UNIT-SPECIFIC FACTORY BLOWER SPEED CONNECTIONS

⚠ FOR LOW TEMPERATURE OPERATION, DISCONNECT CFT, AND INSTALL JUMPER PLUG.

FLASH CODES	DESCRIPTION
ON STEADY	CONTROL FAILURE-REPLACE CONTROL
HEART BEAT	NORMAL OPERATION
2 FLASHES	CONTROL WAITING ON ANTI-SHORT CYCLE DELAY*
3 FLASHES	HPS1-COMPRESSOR LOCK OUT
5 FLASHES	LPS1-COMPRESSOR LOCK OUT
13 FLASHES	COMPRESSOR HELD OFF DUE TO LOW VOLTAGE*
14 FLASHES	EEPROM STORAGE FAILURE (CONTROL FAILURE)
15 FLASHES	CONDENSATE OVERFLOW SWITCH-COMPRESSOR LOCK OUT
16 FLASHES	COAXIAL FREEZE THERMOSTAT-COMPRESSOR LOCK OUT
	*THESE CODES DO NOT REPRESENT ALARMS.

STK-554DMP

## R-410A QUICK REFERENCE GUIDE

**Refer to Installation Instructions for specific installation requirements.**

- R-410A Refrigerant operates at 50 - 70 percent higher pressures than R-22. Be sure that servicing equipment and replacement components are designed to operate with R-410A.
- R-410A Refrigerant cylinders are rose colored.
- Recovery cylinder service pressure rating must be 400 psig. DOT 4BA400 or DOT BW400.
- Recovery equipment must be rated for R-410A.
- Do not use R-410A service equipment on R-22 systems. All hoses, gages, recovery cylinders, charging cylinders and recovery equipment must be dedicated for use on R-410A systems only.
- Manifold sets must be at least 700 psig high side, and 180 psig low side, with 550 psig retard.
- All hoses must have a service pressure rating of 800 psig.
- Leak detectors, must be designed to detect HFC refrigerants.
- Systems must be charged with refrigerant. Use a commercial type metering device in the manifold hose.
- R-410A can only be used with POE type oils.
- POE type oils rapidly absorb moisture from the atmosphere.
- Vacuum pumps will not remove moisture from POE type oils.
- Do not use liquid line driers with a rated working pressure rating less than 600 psig.
- Do not install suction line driers in the liquid line.
- A liquid line drier is required on every unit.
- Do not use an R-22 TXV. If a TXV is to be used, it must be an R-410A TXV.
- Never open system to atmosphere when under vacuum.
- If system must be opened for service, evacuate system then break the vacuum with dry nitrogen and replace filter driers.

# NOTES



P.O. Box 1592, York, Pennsylvania USA 17405-1592  
Copyright © 2015

800-861-1001  
[www.enviro-tec.com](http://www.enviro-tec.com)

Subject to change without notice. Printed in USA  
ALL RIGHTS RESERVED

Form ET145-18-IOM1 (115)  
Issue Date: January 21, 2015  
Supersedes: ET145-18-IOM1 (513)