



**ENVIRO-TEC®**

**FAN POWERED VAV TERMINALS**

**INSTALLATION, OPERATION & MAINTENANCE**

Supersedes: ET130.13-NOM3 (708)

Form ET130.13-NOM3 (615)

**MODELS CFR, CFRQ, CFL, VFR & VFL**

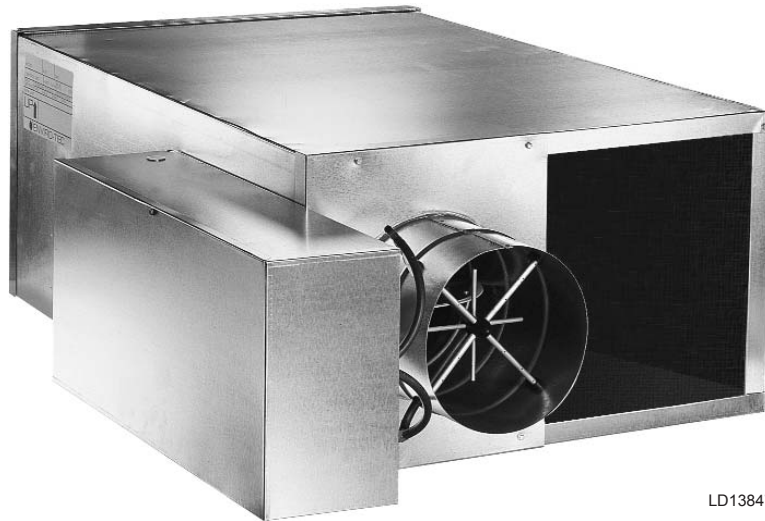

LD13847

# TABLE OF CONTENTS

- SAFETY CONSIDERATIONS.....4**
- INSPECTION .....5**
- STORAGE .....5**
- PRE-INSTALLATION INSPECTION.....5**
- SEQUENCE OF OPERATION.....6**
  - Parallel Flow.....6
  - Series Flow.....6
- INSTALLATION .....6**
  - Clearances .....7
  - Hanging and Mounting Equipment Overhead .....7
  - Duct Connections.....7
  - Critically Sound Applications.....7
  - Coil Connections .....8
  - Electrical.....8
- OPERATION .....8**
  - Start-Up .....8
  - Power Requirements .....8
  - Primary Air Damper and Fan Adjustment .....8
  - Series Flow, PSC Motor with SCR.....9
  - Parallel Flow, PSC Motor with SCR.....9
  - Series Flow ECM Motor Balancing .....10
  - Commissioning.....10
  - Balancing .....10
  - Manual Fan CFM Adjustment .....11
  - Remote Fan CFM Adjustment.....11
  - Status LED .....11
- MAINTENANCE .....11**
  - Factory Provided Damper Actuator .....11
  - Damper Shaft .....11
  - Motor/Blower.....11
    - Cleaning .....12
    - Replacement.....12
  - Coil.....12
    - Cleaning .....12
    - Replacement.....12
  - Electric Heat.....13
    - Replacement.....13
- TROUBLESHOOTING GUIDELINES .....14**
- ECM SPECIFIC TROUBLESHOOTING GUIDELINES.....15**
  - Checking ECM Cables.....15
- VALVE CALIBRATION CHARTS .....17**
- FAN CFM CALIBRATION CURVES - TABLE 3.....18**
- IN-WARRANTY RETURN PROCEDURE.....19**
- SERIES FLOW TERMINAL UNIT WEIGHTS -TABLE 4.....19**
- PARALLEL FLOW TERMINAL UNIT WEIGHTS - TABLE 5.....20**
- REPLACEMENT PARTS LIST .....20**

## SAFETY SYMBOLS

The following symbols are used in this document to alert the reader to areas of potential hazard:



***DANGER*** indicates an imminently hazardous situation which, if not avoided, will result in death or serious injury.



***CAUTION*** identifies a hazard which could lead to damage to the machine, damage to other equipment and/or environmental pollution. Usually an instruction will be given, together with a brief explanation.



***WARNING*** indicates a potentially hazardous situation which, if not avoided, could result in death or serious injury.

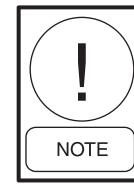

***NOTE*** is used to highlight additional information which may be helpful to you.

## SAFETY CONSIDERATIONS

The equipment covered in this manual is designed for safe and reliable operation when installed and operated within its' design specification limits. To avoid personal injury or damage to equipment or property while installing or operating this equipment, it is essential that qualified, experience personnel familiar with local codes and regulations, perform these functions using good judgment and safe practices. *See the following cautionary statements.*



***ELECTRICAL SHOCK HAZARDS***  
***All power must be disconnected prior to installation and servicing this equipment. More than one source of power may be present. Disconnect, tag and lock out all power sources to avoid electrocution or shock hazards.***



***ROTATING EQUIPMENT HAZARD***  
***Fans may start automatically. Disconnect all power and control circuits prior to servicing to avoid injury. Caution should be exercised due to the possibility of fans "free wheeling" due to connected duct air movement.***



***HOT PARTS HAZARD***  
***Electric heaters may start automatically. Disconnect all power and control circuits prior to servicing to avoid burns.***



***Check that rigging and lifting equipment can safely support the equipment assembly and component weights.***



***All assemblies must be adequately secured during lifting and rigging by temporary supports and restraints until equipment is permanently fastened and set in its' final location per manufacturer's guidelines.***



***All temporary and permanent equipment supports must be capable of safely supporting the equipment's weight as well as any additional live, seismic or dead loads that may be encountered. All supports must be designed to meet applicable local codes and ordinances.***



***All fastening devices must be designed to mechanically lock the assembly in place without the capability of loosening or breaking away due to system operation and vibration.***



***Dampers may activate automatically. Disconnect the control circuits or pneumatic control systems and secure all dampers when servicing damper, actuators or linkage to avoid injury.***



***Wear the appropriate personal protective equipment (gloves, safety glasses, leather closed toe shoes, etc) when handling this equipment recognizing that sheet metal components are being handled.***

## INSPECTION

Upon receipt of equipment, carefully check all items against the bill of lading to ensure that all equipment has been received (including shipped loose items). Note any discrepancy on the bill of lading before signing. Note that “ship loose” items may be included with the base unit or shipped (bulk) on a separate pallet.

Inspect all equipment for any signs of damage caused during transit. On equipment with electric heat, make sure to check the coil fins and/or make sure that the resistance heat coils are not damaged. Note any visual damage on the bill of lading before signing. **Immediately report all visual and concealed damage to the carrier and file a claim with the carrier.**

Locate the model number on the nameplate and check that the correct equipment has been received. Verify that all options have been included, such as controls, filters, heating coils, etc. Also check that equipment voltage agrees with the building parameters. If a discrepancy is discovered between what was ordered and received, contact your local Enviro-Tec representative immediately.



***Do not use flow sensor, connecting tubes, coil stubouts or damper shaft as a handle when lifting or moving equipment as damage may occur.***



***Do not handle by equipment's heating elements, as permanent damage will occur.***



***Check assembly and component weights to be sure that the rigging equipment can handle them safely. Note; also check the centers of gravity and any specific rigging instructions.***



***Check for adequate ventilation so fumes do not migrate through ductwork to occupied spaces when welding or cutting around the equipment.***



***Do not work on damper until associated actuator is disconnected.***



***Never pressurize equipment above specified test pressure.***



***Protect adjacent flammable materials when brazing. Use flame and heat protection barriers where need. Have a fire extinguisher at hand and ready for immediate use.***

## STORAGE

If equipment is to be stored prior to installation, observe the following precautions:

1. Choose a dry storage site that is reasonably level and sturdy to prevent undue stress or permanent damage to the equipment. Set equipment off ground if in moisture prone areas.
2. Cover entire equipment with protective tarp or moisture proof cover. Extend cover under equipment if stored on ground. Secure cover with adequate tie downs. Be sure that piping connections have protective shipping caps installed.
3. Do not stack equipment any higher than how it was shipped. If equipment has been unpackaged since receipt from the factory, do not stack without equivalent support between units as was supplied from the factory.

## PRE-INSTALLATION INSPECTION



***Do not use flow sensor, connecting tubes, coil stubouts or damper shaft as a handle when lifting or moving equipment as damage may occur.***



***Do not handle by equipment's heating elements, as permanent damage will occur.***

While viewing the damper from the discharge of the equipment, disengage the actuator by depressing the manual override button on the side of the actuator and rotate the shaft fully. The damper should close fully and there should be no gaps between the damper gasketing and the inside of the valve.

Units equipped with ECM or 1 horsepower motors will ship from the factory with a removable motor / wheel support installed in the fan housing. It is imperative that this shipping support be removed prior to equipment startup or damage may result to both the motor and the wheel. A label will be affixed to the outside of the unit next to the power entry point, to identify the presence of this shipping insert.

Manually rotate the fan wheel to assure that there are no obstructions within the fan housing.



***Equipment supplied with ECM motors, backward or reverse rotation of the blower is detrimental to the ECM motor.***

## SEQUENCE OF OPERATION

All fan-powered equipment is supplied with a rectangular discharge and comes in one of two configurations:

1. Parallel flow with hot water coils mounted on the plenum induction air opening.
2. Series flow with hot water coils mounted on the discharge opening.

Note that for either configuration, electric heaters (if supplied) are always mounted on the unit discharge opening.

### Parallel Flow

On parallel flow equipment, the primary air valve delivers cooled air to the equipment's outlet. When the space temperature decreases beyond the control of the primary air valve, the fan is started along with the first stage of heat. The fan delivers warm plenum air from the controlled space to the equipment's outlet, which is mixed with the primary air prior to being delivered to the space.

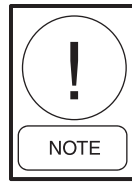

***Either the primary air valve, fan or both can deliver airflow to the occupied space. A back draft damper is provided, when the fan is not operating. The efficiency of this system is the same as standard single duct VAV equipment.***

In a typical control sequence applied to parallel flow equipment, the air valve is closed to a zero minimum airflow before the fan is energized. After the fan has been energized, the reheat will be energized upon a further drop in space temperature. Therefore, little primary air is mixed with the heated air stream.

### Series Flow



***Fan must be energized prior to introduction of air through the primary air valve or the possibilities exist that the fan wheel will operate backwards / counter rotation.***

On series flow equipment, the fan runs continuously whenever the central air handler is in operation.

In response to the space temperature, the air valve modulates the volume of primary air. The re-heat is typically off during the air valve's modulation. Should the space temperature decrease to the point at which a decrease in primary air will not maintain the desired temperature, the reheat will be activated to increase the discharge air temperature.

## INSTALLATION



***Do not use flow sensor, connecting tubes, coil stubouts or damper shaft as a handle when lifting or moving equipment as damage may occur.***



***Do not handle by equipment's heating elements, as permanent damage will occur.***



Terminal equipment with electric heat must be installed in a horizontal plane with respect to the air stream. Low height equipment can be flipped over in the field to vary or change control section handing.

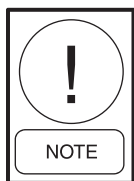

**Consult factory for application utilizing mercury contactors.**

### Clearances

All equipment covered in this document, including those with electric heat, are ETL listed for 0.0" clearance to combustibles. Refer to NEC and/or local codes for minimum electrical clearances required for service. Equipment should not make contact with any structure located above or below the equipment without appropriate isolation. Equipment supplied with bottom access panels requires sufficient clearance to remove access panels for service.

### Hanging and Mounting Equipment Overhead

ENVIRO-TEC strongly recommends that all equipment be suspended from the upper most ceiling or a structural element of the building, independent of the false ceiling grid. Suspension devices are field supplied, sized and designed by others. ENVIRO-TEC will not accept responsibility for equipment mounting supports. Equipment must be installed in a level horizontal plane. Failure to level equipment properly may prevent proper operation of controls. *See Tables 3 and 4 for equipment weights.*

When requested, equipment is supplied with optional hanger brackets for use with (up to) a 3/8" [10mm] diameter hanger rod. *See submittal drawings for hanger bracket locations.*

Hanger straps may be utilized as an alternate means of suspending the equipment. Do not secure hanger straps to electric heaters, coils or control enclosures. Hanger straps can be mounted directly to the sides and bottom of equipment casing, such that they do not interfere with working components or access panels using screws that are no longer than 1" [25mm].

When hanging equipment, always use the support method as prescribed for rectangular duct in the job specifications.

### Duct Connections

All duct connections should be configured and installed in accordance with SMACNA guidelines and all local code requirements. Check to see that duct fasteners are appropriate for the application and do not impinge any internal components. Pay particular attention to internal electrical components.

Fasten and seal all ductwork connections in accordance with project specifications.

Allow a minimum of 1½ duct diameters of straight duct prior to equipment inlet and after equipment discharge.

The diameter of the inlet duct for round valves must be equal to the listed size of the equipment. The round air valve inlet collar of the equipment is 1/8" smaller than listed size in order to allow the round ductwork to slip over the air valve inlet collar. **DO NOT INSERT DUCTWORK INTO AIR VALVE INLET COLLAR.**

When making ductwork connection to air valve inlet collar and insulating air valve inlet, take caution not to damage or remove the flow sensor connections, which are vital to equipment control.

Provide insulation around entire inlet collar (all the way to the equipment casing).

Cut "slits" in the insulation for the flow tubes and secure with duct tape.

Permissible discharge duct connections are straight flanged, slip and drive or drive and screw.

If equipment is to be installed in a location with high humidity, external insulation around the heating coil should be installed.

After all connections are made, check that the entire ductwork system is airtight. In some high-pressure systems, duct sealer may be necessary.

### Sound Critical Applications

Flexible duct connectors are not recommended on equipment discharge. The sagging membrane of these fittings can cause turbulence and locally high air velocities that generate noise. Also, lightweight membrane material allows noise to breakout, which can increase sound levels in the space below.

## Coil Connections

Hot water and steam coils are male sweat connection. Use appropriate brazing alloy for system temperature and pressure. Refer to equipment construction submittal drawing for specific connection size. **MAXIMUM HYDRONIC SYSTEM OPERATING PRESSURE MUST NOT EXCEED 300 PSIG. MAXIMUM STEAM SYSTEM PRESSURE MUST NOT EXCEED 15 PSIG.**

If necessary, you can change coil connection handing on one and two row coils from left-hand to right-hand (and vice-versa) by rotating the coil “like a steering wheel” 180° about its central axis when facing the fins. **For three and four row coils, consult factory.**

## Electrical

All field wiring must comply with NEC and all local codes. Electrical and control diagrams are affixed to the interior of the control enclosure box.

Minimum circuit ampacity (MCA) designates the maximum operating load of the equipment for sizing wire feeders. Supply Circuit Protection designates the largest breaker in the electrical service panel that can be used to protect the equipment.

Use Copper conductors only.

## OPERATION

### Start-Up

Thorough safety precautions should always be taken when performing startup and service. Refer to safety considerations at the beginning of this Operation Manual. Only qualified individuals should perform these tasks.

Prior to start-up, the project control sequence/wiring diagram should be obtained and thoroughly understood. If factory supplied analog or DDC controls are utilized, refer to the applicable Operation Manual for start-up and balancing information. Check that all electrical work is finished and properly terminated. Check that all electrical connections are tight and that the proper voltage is connected.

Check to make sure that heater elements are not damaged, free of all foreign material and proper control interlocks have been made before energizing the electric heater.

## Power Requirements

Three Phase AC power imbalance must not exceed 2%. Be sure that the following guides are met:

1. AC power is within 10% of rated voltage at rated frequency. (*See equipment nameplate for ratings*)
2. AC power is within 5% of rated frequency at rated voltage.
3. A combined variation in the voltage and frequency of 10% (sum of absolute values) of rated values provided the frequency variation does not exceed 5% of rated frequency.

## Primary Air Damper and Fan Adjustment

Unit should not be balanced until the incoming power supply is at the permanent voltage condition. All discharge ductwork must be connected. The minimum recommend discharge static pressure for all fan-powered equipment is 0.1” wg. and 0.2” on 3/4hp and larger (*see fan curves located on the Enviro-Tec web site for specifics*). All foreign materials should be removed from the duct system. Optional filters should be installed as required.

Unless otherwise specified, the fan motor has three speeds. Fan speed is selected in the electrical control enclosure by one of two methods. For units with dual motors, see Figure 1A showing how the fan speed is selected by placement of a factory supplied jumper wire on a terminal strip. Otherwise see Figure 1B which shows the wire to wire fan speed selection method. Simply insert the male quick connect (from control circuitry) into the female quick connect which corresponds to high (black), medium (blue), or low (red) motor speeds. Units are set to low speed at the factory as standard in order to optimize energy efficiency. A three position rotary switch is optional.



### ***ELECTRICAL SHOCK HAZARD***

***All power must be disconnected prior to changing jumper or serious injury or death will result.***

All fan-power equipment is shipped with an electronic solid state fan speed controller (SCR) for PSC motors. The SCR is located in the control enclosure. Using a 1/8” flat blade screwdriver, adjusting the manual potentiometer clockwise will increase the motor speed; adjusting the potentiometer counterclockwise will decrease the motor speed.



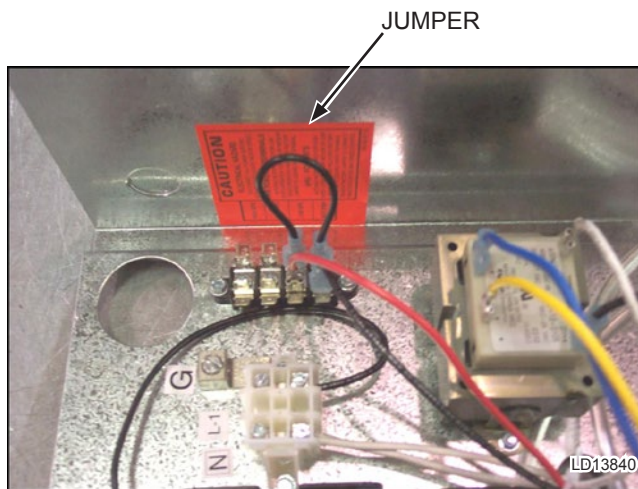

**FIGURE 1A - FAN SPEED CONTROL WITH JUMPER**

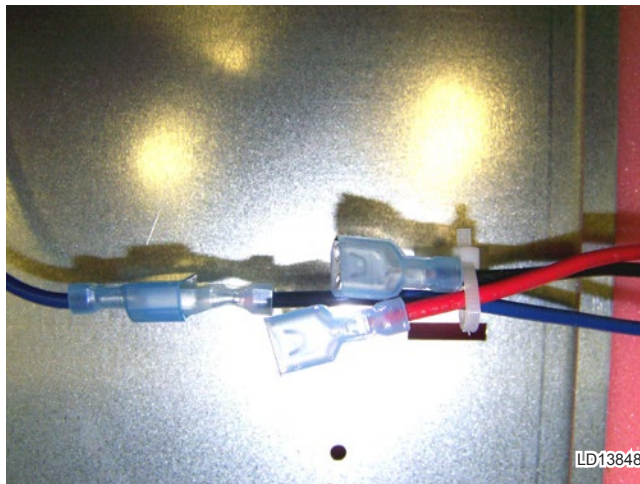

**FIGURE 1B - WIRE TO WIRE FAN SPEED SELECTION**

#### Series Flow, PSC Motor with SCR

1. Make sure that the motor speed is at maximum by turning the potentiometer located on the Fan Speed Control (SCR) all the way clockwise.
2. Energize motor and let motor operate for a minimum of 15 minutes. During this run-in, check ductwork for any leaks and repair as necessary.
3. If remote balancing dampers are present set them to full open.
4. Attach a manometer or magnehelic to the differential pressure ports in the pneumatic tubing leading to the high and low side of the inlet air probe and measure the velocity pressure. Adjust and set the primary maximum airflow as necessary to meet job site requirements. *See Table 2, Airflow vs. Velocity Pressure chart.* This chart, with different inlet sizes, is also located on the side of the equipment.

5. If balancing dampers are present, adjust and set proportionally to desired position. To minimize noise levels, leave these dampers in the most open position possible.
6. If total airflow is too low, de-energize unit and move jumper to next higher speed.
7. Energize unit and adjust Fan Speed Control (SCR) for desired total airflow.
8. The maximum primary air balance may be checked using the optional radiated sound damper, or by suspending a sheet of notebook paper over the inlet using a small piece of tape. If the damper or notebook paper is blowing out of the unit, the primary maximum airflow is too high. If the paper or damper is being pulled into the unit, the maximum primary airflow is too low. Optimum balance is achieved when the damper or paper hangs straight down.

#### Parallel Flow, PSC Motor with SCR

1. Make sure that the motor speed is at maximum by turning the potentiometer located on the Fan Speed Control (SCR) all the way clockwise.
2. With primary air valve in the closed position, energize motor and let motor operate for a minimum of 15 minutes. During this run-in, check ductwork for any leaks and repair as necessary.
3. If balancing dampers are present, adjust and set proportionally to desired position. To minimize noise levels, leave these dampers in the most open position possible.
4. If fan airflow is too low, de-energize unit and move jumper to next higher speed.
5. De-energize motor and perform minimum and maximum primary air balance. *See Table 2, Airflow vs. Velocity Pressure chart.* This chart, with different inlet sizes, is also located on the side of the equipment.

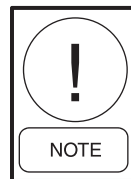

***An extra jumper is required on units with 480 VAC motors. See wiring diagram attached to unit.***

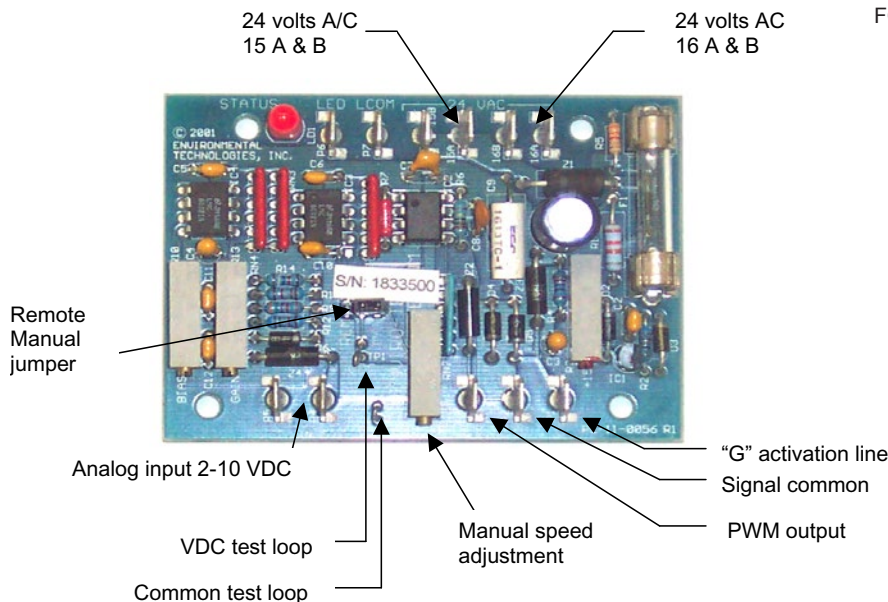

FIGURE 2 - ETPWM BOARD LAYOUT

LD13841

### Series Flow ECM Motor Balancing



***Fan must be energized prior to introduction of air through the primary air valve or the possibility exists that the fan wheel will operate backward (counter rotation). Reverse / counter rotation of the blower over a period of time will damage the ECM motor.***

See Figure 2 for ETPWM Board Layout.

### Commissioning

1. If remote balancing dampers are present set them to full open.
2. Make sure there are no obstructions in the discharge ductwork and/or at the plenum opening. If the unit has a radiated sound damper at the plenum opening, make sure it swings freely.
3. With unit de-energized, disable fan by disconnecting one of the wires leading to fan relay coil or contacts.
4. Energize unit.
5. Verify that there is 22 to 28 VAC across terminals 15 and 16 of ETPWM board.
6. Verify that there is 15 VDC across terminals G (+) and COM (-) of ETPWM board.
7. Connect voltmeter to wire loop VDC (+) and wire loop COM (-) of ETPWM board. Verify DC voltage is between 5.1 and 9.9 VDC.
8. De-energize unit and reconnect wire to fan relay removed in step 3. Make sure that all wires are reconnected per electrical schematic shipped with unit.

9. Energize unit and let motor operate for a minimum of 15 minutes. During this run-in, check ductwork for any leaks and repair as necessary.

### Balancing

1. Adjust fan to the design CFM using either the Manual or Remote Fan CFM Adjustment method listed below.
2. Attach a manometer or magnehelic to the differential pressure ports in the pneumatic tubing leading to the high and low side of the inlet air probe and measure the velocity pressure. Adjust and set the primary maximum airflow as necessary to meet job site requirements. See *Table 2, Airflow vs. Velocity Pressure chart*. This chart, with different inlet sizes, is also located on the side of the equipment.
3. If balancing dampers are present, adjust and set proportionally to desired position. To minimize noise levels, and prevent premature ECM motor failure, leave these dampers in the most open position possible.
4. The maximum primary air balance may be checked using the optional radiated sound damper, or by suspending a sheet of notebook paper over the inlet using a small piece of tape. If the damper or notebook paper is blowing out of the unit, the primary maximum airflow is too high. If the paper or damper is being pulled into the unit, the maximum primary airflow is too low. Optimum balance is achieved when the damper or paper hangs straight down.

## Manual Fan CFM Adjustment

1. Verify that the jumper on ETPWM board is in the “MAN” position (shipped from factory in Manual mode)
2. Connect voltmeter to wire loop VDC (+) and wire loop COM (-).
3. Determine the DC voltage for required airflow from the Fan Calibration Curve supplied on the side of the equipment. Use the bottom (5 to 10 volts DC) scale on the chart. An example Fan Calibration curve is shown in Table 3; however, the curve on the side of the equipment should be used in determining the voltage.
4. Using a 1/8” flat bladed screwdriver, adjust the manual speed potentiometer, labeled SPD, to obtain the required voltage. Clockwise increases airflow, counterclockwise decreases airflow.
5. Do not set the voltage lower than 5.1 VDC or higher than 9.9 VDC or motor may experience starting problems.
6. Do not set the balance voltage outside limits of the voltage/CFM curve or erratic motor operation and eventual failure may result.

## Remote Fan CFM Adjustment

1. Relocate the jumper on ETPWM board to the REM position.
2. Determine the DC voltage for required airflow from the Fan Calibration Curve supplied on the side of the equipment. Use the top (2 to 10 Analog Input Volts DC) scale on the chart. An example Fan Calibration curve is shown in Table 3; however, the curve on the side of the equipment should be used in determining the voltage.
3. Remotely adjust the external voltage source to the desired volts DC for required airflow.
4. Do not operate motor at control voltage lower than 2.1 VDC or higher than 9.9 VDC or motor may experience starting problems.
5. Do not operate motor at control voltage outside limits of the voltage/CFM curve or erratic motor operation, and eventual failure may result.

## Status LED

When the motor is running, the LED alternates between CFM and RPM indications. In the RPM mode, LED turns on for a period of approximately 220 microseconds at a rate of 36 pulses per revolution. This mode lasts for ten seconds. Due to the rapid rate, LED will appear to be dimly lit, not flashing. As RPM is increased, brightness will increase. In the CFM mode, the LED will flash slowly, and at maximum brightness, once for every 100 CFM. Accuracy is +/- one flash. LED will then return to RPM mode, and cycle will repeat.

## MAINTENANCE

### Factory Provided Damper Actuator

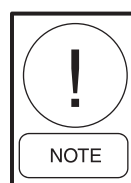

*Equipment may be supplied with a field or factory mounted damper actuator. If actuator is factory provided, see ACT24 Floating-Point Control Direct Coupled Actuator document. See Table 1 for maximum wire lengths for control voltage.*

WIRE SIZE	MAX FEET
16 GA	1225 FT
18 GA	725 FT
20 GA	400 FT
22 GA	200FT

### Damper Shaft

There is an indicator on the end of the damper shaft that can be used to determine the position on the damper blade. If the indicator is horizontal, the damper is completely open.

### Motor/Blower

Fan powered terminal unit motors are equipped with permanently lubricated bearings and require little or no maintenance. The frequency of required cleaning is dependent on the operating hours of the system, filter maintenance and efficiency as well as dirt load. Periodically inspect the motor and blower-housing wheel for accumulation of dust and clean as necessary.

## Cleaning

1. Disconnect all electrical power to the equipment, tag and lock out power source.
2. Gain access to motor housing through access panel.
3. Use soft brush and vacuum to remove loose debris from motor housing.
4. Replace access panels and restore electrical power to equipment.
5. Use caution to assure that any contaminated material does not contact other areas of the equipment or building. **Properly dispose of all contaminated materials.**

## Replacement

1. Disconnect all electrical power to the equipment, tag and lock out power source.
2. Remove bottoms access doors by removing the screws from the access door and then remove side rail screws to access to the motor.
3. Disconnect fan motor wiring.
4. Remove securing fan assembly to discharge
5. Loosen fan wheel set screw.
6. Remove nuts securing motor to housing and remove motor.
7. Remove fan cut off.
8. Remove fan wheel and clean as needed.
9. Reinstall wheel, cut off, motor, and housing.

## Coil

The frequency of required cleaning is dependent on the operating hours of the system, filter maintenance and efficiency as well as dirt load.



***Important: Coils may become externally fouled as result of normal operation. Dirt on the surface of the coil reduces its ability to transfer heat that can result in reduced performance and increased operating energy cost. If the dirt on the surface of the coil becomes wet, microbial growth (mold) can result, possibly causing unpleasant odors and serious health related indoor air quality problems.***



***Fin edges are sharp. Fins are fragile; care must be exercised to avoid damaging fins. Do not use solutions to clean coils; drain pans are not present to remove collected solution.***

## Cleaning

1. Disconnect all electrical power to the equipment, tag and lock out power source.
2. Put on appropriate personal protective equipment.
3. Gain access to coil either through ductwork or optional coil access panel.
4. Use soft brush and vacuum to remove loose debris from sides of coil.
5. Straighten any coil fins that may have been damaged during cleaning process with fin comb.
6. Replace ductwork or access panel and restore electrical power to equipment.
7. Use caution to assure that any contaminated material does not contact other areas of the equipment or building. **Properly dispose of all contaminated materials.**

## Replacement

1. Disconnect all electrical power to the equipment, tag and lock out power source.
2. Disconnect all ductwork, if applicable.
3. Remove filter rails/ filter clips, if applicable.
4. Cut or un-braze water connection at coil.
5. Disconnect coil from equipment by removing screws on the exterior perimeter of the coil. Low height equipment only has mounting screws located on the sides of the equipment.



## Electric Heat

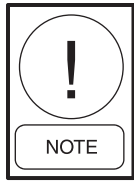

***Electric heat requires a minimum of 0.1" W.G. downstream static pressure for proper operation.***

Electric heaters come equipped with a primary auto-reset limit switch to provide protection against overheating. The primary auto-reset limit switch automatically cuts the heater off when overheating occurs, and turns the heater back on when the elements have cooled down. Should the secondary one-time trip limit switch trip, they will need to be replaced with a limit switch that has the same trip temperature as the one-time trip limit switch originally supplied with the electric heater. Optional secondary manual reset limit switches are available.

Electric heaters may be equipped with optional disconnect switch, fuses and airflow proving switch.

## Replacement

1. Disconnect all electrical power to the equipment, tag and lock out power source.
2. Disconnect discharge ductwork from unit.
3. Remove electric heat assembly from equipment.
4. Before removing wires from the element rack T-Plate, mark where the wires are connected so that they can be reconnected correctly on the new element rack.
5. Remove the wires and screws holding the heater T-plate in the control enclosure and remove element rack.
6. Insert new element rack into control enclosure and replace screws to secure the element rack to control enclosure.
7. Replace wires.
8. Close control enclosure cover before turning on the power.

<b>TROUBLESHOOTING GUIDELINES</b>		
<b>PROBLEM</b>	<b>POSSIBLE CAUSE</b>	<b>CORRECTIVE ACTION</b>
<b>Motor Fails to Start</b>	Blown fuse or open circuit breaker	Replace fuse or reset circuit breaker; verify and correct source of overload.
	Shipping Cardboard insert in fan wheel	Remove insert and restart.
	Improper wiring connections	Check wiring with diagram supplied on unit.
	Improper current supply	Compare actual supply power with motor nameplate recommendations. Contact power company for adjustments.
	Mechanical failure	Check motor and confirm rotates freely.
<b>Motor Overheats</b>	Overloaded motor	Reduce load or replace with a larger motor (refer factory).
	Motor fan is clogged with dirt preventing proper ventilation	Remove fan cover, clean fan and replace cover. May be necessary to replace motor.
	Lack of required external static pressure	Add required external static pressure.
<b>Excessive Motor Noise</b>	Motor mounting bolts loose	Tighten motor mounting bolts.
	Fan wheel rubbing on fan housing	Align wheel in housing.
	Loose fan wheel	Align and tighten.
	SCR set too low	Select lower tap to Reduce motor speed and re-adjust fan SCR.
<b>Low Coil Capacity</b>	Incorrect airflow	Check fan's operating conditions.
	Incorrect GPM	Check water pumps, valves and lines for obstructions.
	Dirty coil fins	Clean coil Fins.
	Dirty filter (where applicable)	Replace filter.
	Incorrect water temperature	Provide proper water temperature.
<b>Heater Does Not Operate</b>	No Power	Check Disconnect.
	No Control Voltage	Check transformer and transformer fusing (if applicable) replace if necessary.
	Blown Fuse	Replace fuse.
	Open Limit (primary or secondary)	Replace limits or reset as applicable.
		Check for continuity across limit to determine if open, replace as necessary.
	Airflow Incorrect Direction	Check sensing tube, red tube = high and black tube = low, rotate if needed.
	Low External Static Pressure	Increase airflow to obtain a minimum of .1 in. w.c. external static.
Damaged elements	Check for open or damaged elements and replace as necessary.	
<b>Low or High Temperature Rise</b>	Incompatible Thermostat or Controller	Check Wiring.
		Check for compatibility.
	Problems with Additional Stages	Check location of thermostat; might be installed in a "too hot" or "too cold" location. Check heat outputs on controller.
		Check contactors for open coil.
		Check for damaged elements.
Incorrect CFM	Check for blocked duct or location of heater.	
<b>Heater with SSR Does Not Operate</b>	Incorrect Signal Applied	Verify signal input.
	Interface Board Fuse Blown	Replace fuse.



ECM SPECIFIC TROUBLESHOOTING GUIDELINES		
PROBLEM	POSSIBLE CAUSE	CORRECTIVE ACTION
<b>Motor Fails to Start</b>	CFM Adjustment voltage above 9.9 VDC or below 5.1 VDC	Properly adjust CFM voltage.
	ECM cables improperly seated at motor	Unplug cables from motor and re-install, making sure plugs on cables are fully seated in motor receptacles.
	ECM cables open or intermittent	Replace cable(s). <i>See section on checking cables below.</i>
	Mechanical failure	Check motor and confirm it rotates freely.
	Electrical failure	Replace motor.
	Fan Relay Contacts Oxidized/Sulfidized	Replace fan relay.
<b>Motor Surges</b>	Fan CFM adjustment voltage outside range of Fan Calibration Curve	Adjust voltage to value within range of Fan Calibration Curve.
	ESP (external static pressure) too high	Verify balancing dampers as open as possible (at least one should be fully open). Verify radiated sound damper (if supplied) swings freely. Verify plenum opening is unobstructed. Verify filter (if supplied) is not dirty and does not obstruct flow of plenum air.
<b>Excessive Motor Noise</b>	Motor mounting bolts loose	Tighten motor mounting bolts.
	Fan wheel rubbing on fan housing	Align wheel in housing.
	Loose fan wheel	Align and tighten.
<b>Poor Performance</b>	Lack of required external static pressure	Add required external static pressure.
	Wrong Program	Contact Factory.
<b>Motor Runs in Reverse, Doesn't Respond to Speed Adjustment</b>	Motor Failure	Replace.

### Checking ECM Cables

Remove power from the unit. Unplug signal cable at motor, but leave quick connects attached to ETPWM board and fan relay or quick connect terminal block (*see Figure 3 and 4*). Use ohmmeter to check continuity. Repeat process for three wire power cable if signal cable does not appear to be defective (*see Figure 3 and 5*).

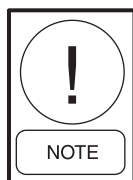

***Only very light force is required when inserting meter probe into plug. Excess force will damage contacts.***

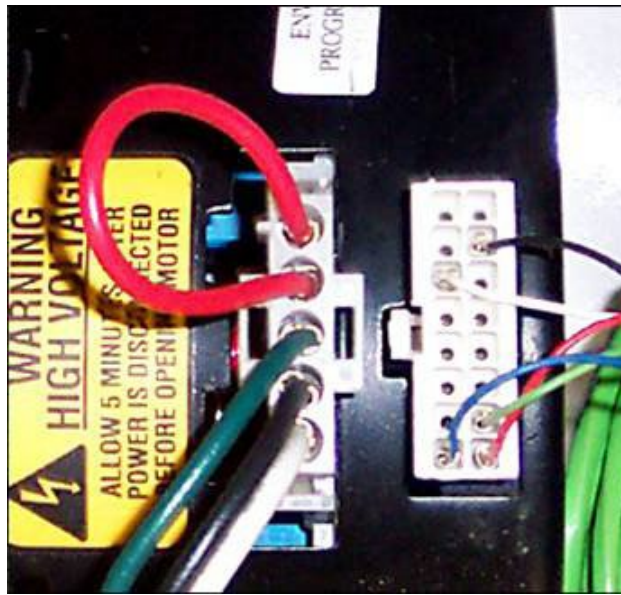

LD13842

FIGURE 3

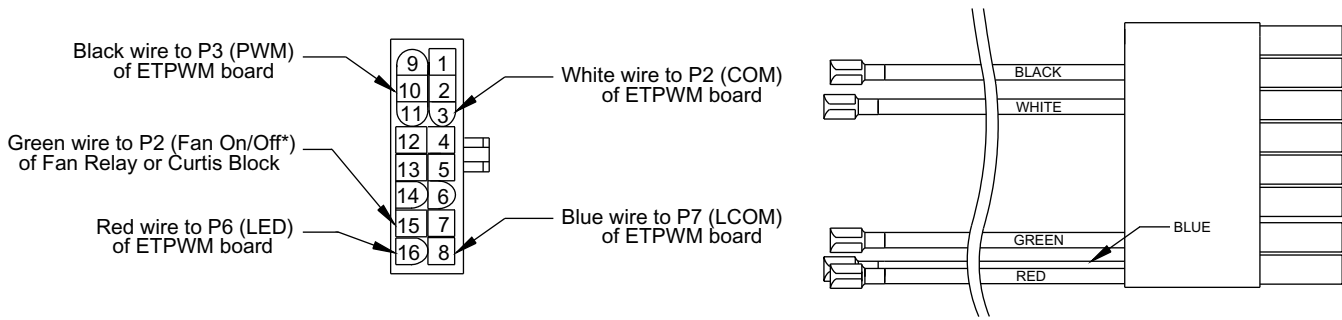

LD13843

FIGURE 4

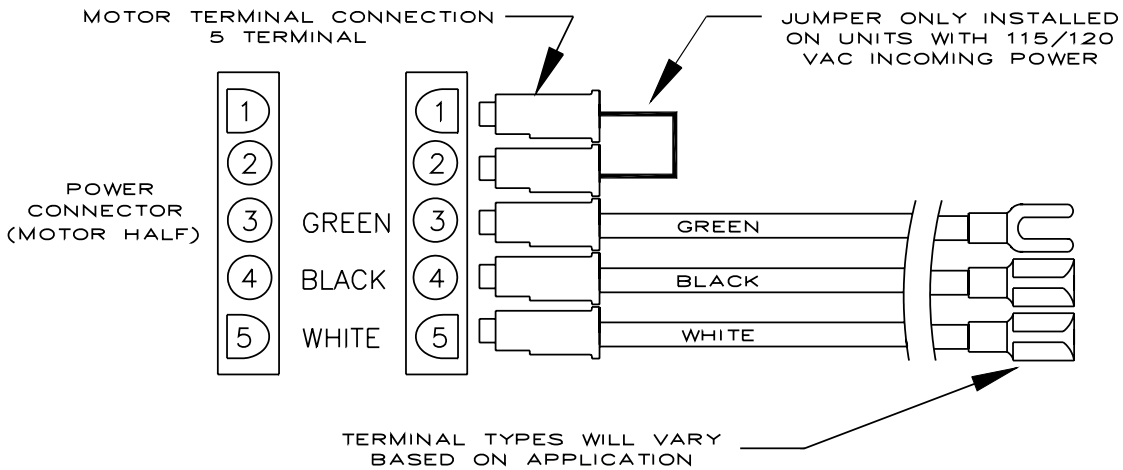

LD13844

FIGURE 5

**VALVE CALIBRATION CHARTS**

Applicable calibration charts are affixed to each unit or may be downloaded from the ENVIRO -TEC® website at [www.enviro-tec.com](http://www.enviro-tec.com).

**TABLE 2**

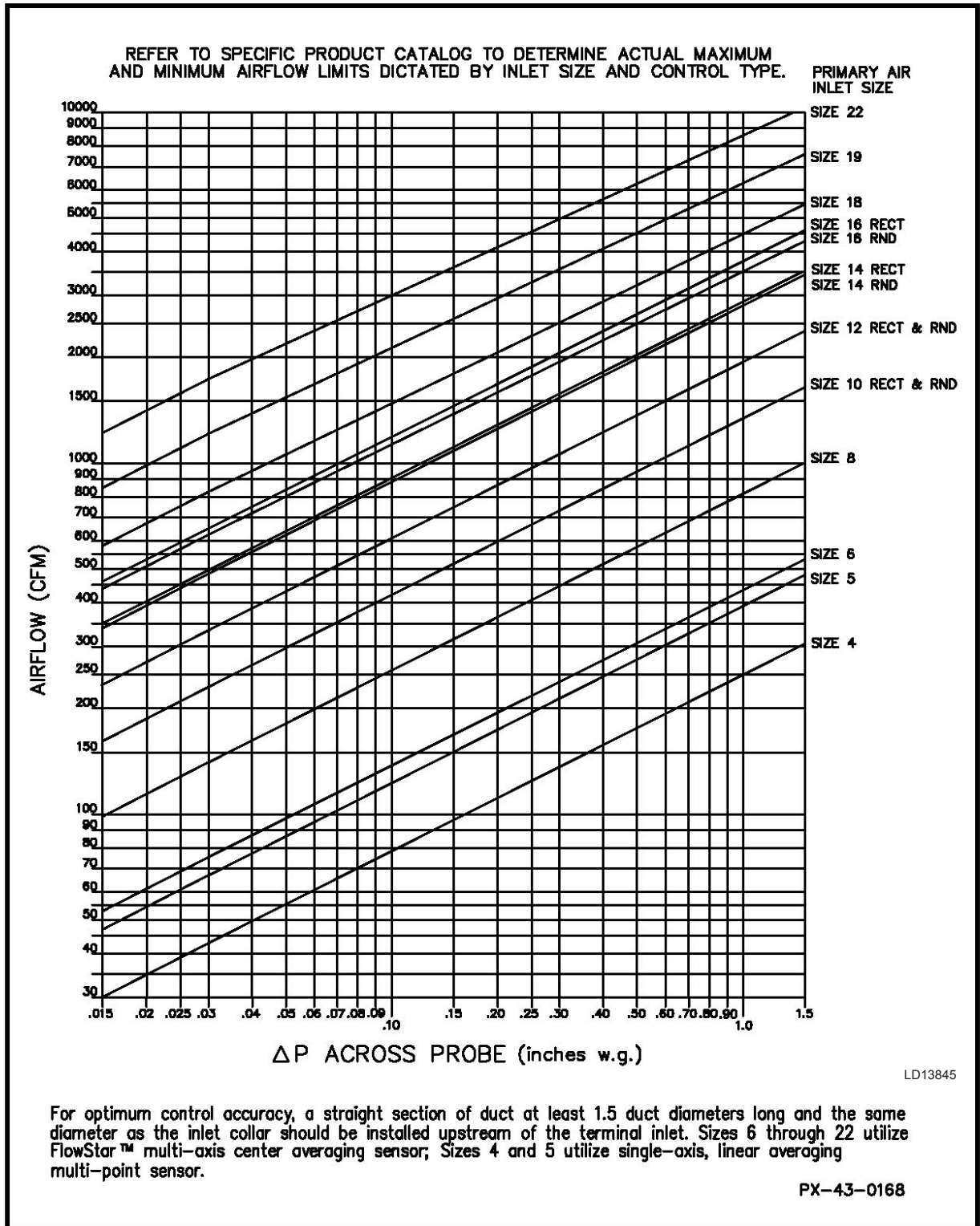

FAN CFM CALIBRATION CURVES - TABLE 3

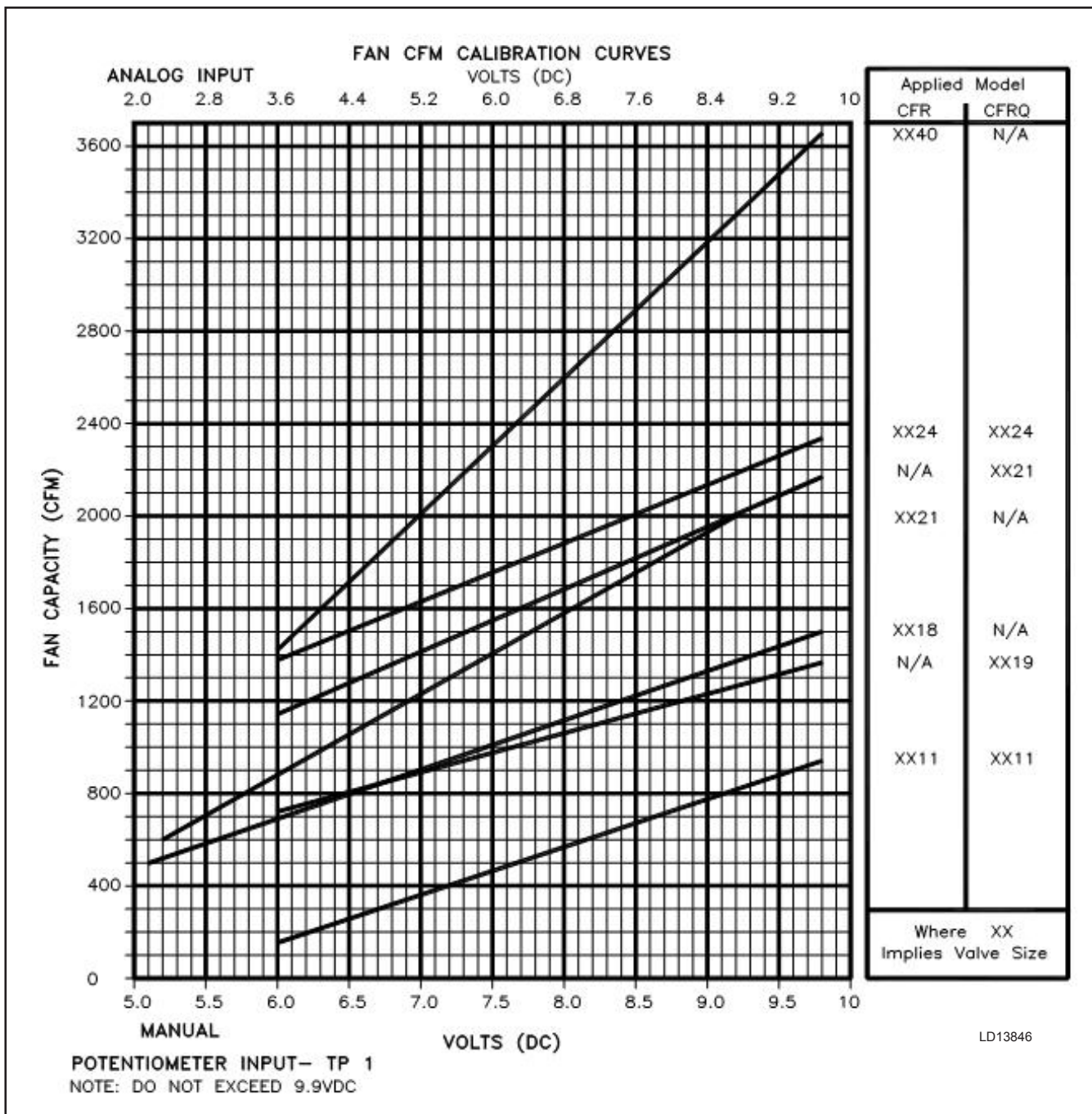

**IN-WARRANTY RETURN PROCEDURE**Refer to ENVIRO -TEC Warranty Parts Policy at [www.enviro-tec.com](http://www.enviro-tec.com).**SERIES FLOW TERMINAL UNIT WEIGHTS -TABLE 4**

CFR (22 GA)							
BASE UNIT WEIGHT		ADDERS TO BASE UNIT WEIGHT					
SIZE	SINGLE WALL	DOUBLE WALL	WATER COIL				ELEC. HEAT
			1 ROW	2 ROW	3 ROW	4 ROW	
0506	58	13	5	7	10	13	20
0606	57	13	5	7	10	13	20
0806	58	13	5	7	10	13	20
0611	59	13	5	7	10	13	20
0811	60	14	5	7	10	13	20
1011	61	14	5	7	10	13	20
0818	75	16	7	11	16	22	23
1018	77	17	7	11	16	22	23
1218	79	17	7	11	16	22	23
1021	79	17	9	11	16	22	23
1221	81	18	9	11	16	22	23
1421	83	18	9	11	16	22	23
1224	108	24	11	23	34	45	27
1424	111	24	11	23	34	45	27
1230	174	38	21	42	63	84	42
1430	177	39	21	42	63	84	42
1630	179	39	21	42	63	84	42
1440	181	40	21	42	63	84	42
1640	184	40	21	42	63	84	42
1644	194	42	21	42	63	84	52
1844	209	46	21	42	63	84	52

**PARALLEL FLOW TERMINAL UNIT WEIGHTS - TABLE 5**

VFR (22 GA)							
BASE UNIT WEIGHT		ADDERS TO BASE UNIT WEIGHT					
SIZE	SINGLE WALL	DOUBLE WALL	WATER COIL				ELECTRIC HEAT
			1 ROW	2 ROW	3 ROW	4 ROW	
4	44	PENDING	10	14	18	22	18
5	44		10	14	18	22	18
6	46		10	14	18	22	18
8	48		10	14	18	22	20
10	85		14	19	25	30	27
12	87		14	19	25	30	31
14	118		16	21	29	34	26
16	120		16	21	29	34	31

**REPLACEMENT PARTS LIST**

SERIES FLOW TERMINALS						
MOTORS AND BLOWERS, MODEL CFR						
SIZE	H/P	MOTOR			BLOWER SIZE	PART NO.
		120	208/230	277		
XX04	1/12	PM-02-1412	PM-02-1413	PM-02-1414	5.75-7	PM-06-0005
XX06	1/6	PM-02-0026	PM-02-0030	PM-02-0032	9-4T	PM-06-0119
XX11	1/4	PM-02-0046	PM-02-0051	PM-02-0052	9-7T	PM-06-0122
XX18	1/2	PM-02-0068	PM-02-0072	PM-02-0076	9-9R	PM-06-0124
XX21	3/4	PM-02-0098	PM-02-0104	PM-02-0106	10-10T	PM-06-0135
XX24	1	PM-02-0124	PM-02-0126	PM-02-0128	10-9R	PM-06-0134
XX30	2 @ 1/2	PM-02-0068	PM-02-0072	PM-02-0076	2 @ 9-9R	PM-06-0124
XX40	2 @ 3/4	PM-02-0098	PM-02-0104	PM-02-0106	2 @ 10-10T	PM-06-0135
XX44	2 @ 1	PM-02-0124	PM-02-0126	PM-02-0128	2 @ 10-9R	PM-06-0134

MOTORS AND BLOWERS, MODEL CFRQ						
SIZE	H/P	MOTOR			BLOWER SIZE	PART NO.
		120	208/230	277		
XX06	1/6	PM-02-0026	PM-02-0030	PM-02-0032	9-4T	PM-06-0119
XX11	1/4	PM-02-0046	PM-02-0051	PM-02-0052	9-7T	PM-06-0122
XX17	1/2	PM-02-0068	PM-02-0072	PM-02-0076	10-8T	PM-06-0132
XX19	3/4	PM-02-0098	PM-02-0104	PM-02-0106	10-9T	PM-06-0133
XX21	1	PM-02-0124	PM-02-0126	PM-02-0128	10-10T	PM-06-0135
XX24	1	PM-02-0124	PM-02-0126	PM-02-0128	10-9R	PM-06-0134
XX30	2 @ 1/2	PM-02-0068	PM-02-0072	PM-02-0076	2 @ 9-9R	PM-06-0124



<b>ECM MOTOR OPTION FOR MODELS CFR AND CFRQ</b>			
<b>SIZE</b>	<b>H/P</b>	<b>MOTOR</b>	
		<b>120/240</b>	<b>277</b>
XX11	1/3	PM-02-1334	PM-02-1302
XX18	1/2	PM-02-1335	PM-02-1303
XX19	1/2	PM-02-1335	PM-02-1303
XX21	3/4	PM-02-1336	PM-02-1304
XX24	1	PM-02-1337	PM-02-1305
XX40	2 @ 1/2	PM-02-1335	PM-02-1303

<b>MOTORS AND BLOWERS, MODEL CFL</b>						
<b>SIZE</b>	<b>H/P</b>	<b>MOTOR</b>			<b>BLOWER SIZE</b>	<b>PART NO.</b>
		<b>120</b>	<b>208/230</b>	<b>277</b>		
XX06	1/6	PM-02-0026	PM-02-0030	PM-02-0032	9-4R	PM-06-0118
XX08	1/4	PM-02-1404	PM-02-1403	PM-02-1402	10-4R	PM-06-0145
XX10	1/4	PM-02-1404	PM-02-1403	PM-02-1402	10-5R	PM-06-01
XX19	2 @ 1/4	PM-02-1404	PM-02-1403	PM-02-1402	2 @ 10-4R	PM-06-0145

<b>ECM MOTOR OPTIONS FOR MODEL CFL</b>			
<b>SIZE</b>	<b>H/P</b>	<b>MOTOR</b>	
		<b>120/240</b>	<b>277</b>
XX06	1/3	PM-02-1405	PM-02-1406
XX08	1/3	PM-02-1405	PM-02-1406
XX10	1/2	PM-02-1407	PM-02-1408
XX19	2 @ 1/3	PM-02-1405	PM-02-1406

<b>PARALLEL FLOW TERMINALS</b>						
<b>MOTORS AND BLOWERS, MODEL VFR</b>						
<b>SIZE</b>	<b>H/P</b>	<b>MOTOR</b>			<b>BLOWER SIZE</b>	<b>PART NO.</b>
		<b>120</b>	<b>208/230</b>	<b>277</b>		
XX04	1/12	PM-02-1412	PM-02-1413	PM-02-1414	5.75-7	PM-06-0005
XX06	1/6	PM-02-0026	PM-02-0030	PM-02-0032	9-4T	PM-06-0119
XX11	1/4	PM-02-0046	PM-02-0051	PM-02-0052	9-7T	PM-06-0122
XX18	1/2	PM-02-0068	PM-02-0072	PM-02-0076	10-9T	PM-06-0133
XX21	3/4	PM-02-0098	PM-02-0104	PM-02-0106	10-10T	PM-06-0135
XX24	1	PM-02-0124	PM-02-0126	PM-02-0128	10-9R	PM-06-0134

<b>ECM MOTOR OPTIONS FOR MODEL VFR</b>			
<b>SIZE</b>	<b>H/P</b>	<b>MOTOR</b>	
		<b>120/240</b>	<b>277</b>
XX06	1/3	PM-02-1334	PM-02-1302
XX11	1/2	PM-02-1335	PM-02-1303
XX18	1/2	PM-02-1335	PM-02-1303
XX21	3/4	PM-02-1336	PM-02-1304
XX24	1	PM-02-1337	PM-02-1305

<b>MOTORS AND BLOWERS, MODEL VFL</b>						
<b>SIZE</b>	<b>H/P</b>	<b>MOTOR</b>			<b>BLOWER PART NO.</b>	
		<b>120</b>	<b>208/230</b>	<b>277</b>		
XX04	1/8	PM-02-0001	PM-02-0003	PM-02-0005	PM-06-00148	
XX09	1/4	PM-02-1367	PM-02-1368	PM-02-1369	PM-06-00148	
XX15	1/2	PM-02-1376	PM-02-1377	PM-02-1378	PM-06-00150	

<b>MAGNETIC CONTACTORS</b>						
<b>AMPS</b>	<b># OF POLES</b>	<b>COIL VOLTAGE</b>				
		<b>24</b>	<b>120</b>	<b>240</b>	<b>277</b>	<b>480</b>
25	1	PE-05-1251	PE-05-1252	PE-05-1256	PE-05-1255	PE-05-1257
	2	PE-05-2251	PE-05-2252	PE-05-2256	PE-05-2255	PE-05-2257
	3	N/A	N/A	N/A	N/A	N/A
30	1	PE-05-1301	PE-05-1302	PE-05-1306	PE-05-1305	PE-05-1307
	2	PE-05-2301	PE-05-2302	PE-05-2306	PE-05-2305	PE-05-2307
	3	PE-05-3301	PE-05-3302	PE-05-3306	PE-05-3305	N/A
35	1	N/A	N/A	N/A	N/A	N/A
	2	PE-05-2351	PE-05-2352	PE-05-2356	PE-05-2355	N/A
	3	PE-05-3351	PE-05-3352	PE-05-3356	PE-05-3355	N/A
40	1	PE-05-1401	PE-05-1402	PE-05-1406	PE-05-1405	N/A
	2	PE-05-2401	PE-05-2402	PE-05-2406	PE-05-2405	N/A
	3	PE-05-3401	PE-05-3402	PE-05-3406	PE-05-3405	N/A
50	1	PE-05-1501	N/A	PE-05-1506	N/A	N/A
	2	PE-05-2501	PE-05-2502	PE-05-2506	PE-05-2505	N/A
	3	PE-05-3501	PE-05-3502	PE-05-3506	PE-05-3505	N/A

<b>MERCURY CONTACTORS</b>						
<b>AMPS</b>	<b># OF POLES</b>	<b>COIL VOLTAGE</b>				
		<b>24</b>	<b>120</b>	<b>240</b>	<b>277</b>	<b>480</b>
35	1	PE-26-1351	PE-26-1352	PE-26-1356	PE-26-1355	PE-26-1357
	2	PE-26-2351	PE-26-2352	PE-26-2356	PE-26-2355	PE-26-2357
	3	PE-26-3351	PE-26-3352	PE-26-3356	PE-26-3355	PE-26-3357
50	1	PE-26-1501	PE-26-1502	PE-26-1506	PE-26-1505	PE-26-1507
	2	PE-26-2501	PE-26-2502	PE-26-2506	PE-26-2505	PE-26-2507
	3	PE-26-3501	PE-26-3502	PE-26-3506	PE-26-3505	PE-26-3507

<b>CAPACITORS</b>		
<b>µf</b>	<b>PART #</b>	<b>VOLTAGE</b>
3	PE-12-0499	370
4	PE-12-0500	370
5	PE-12-0501	370
6	PE-12-0502	370
7.5	PE-12-0503	370
10	PE-12-0504	370
12.5	PE-12-0505	370
15	PE-12-0506	370
20	PE-12-0508	370
3	PE-12-0509	440

<b>TRANSFORMERS</b>					
	<b>120</b>	<b>208/240</b>	<b>277</b>	<b>480</b>	<b>575</b>
VA	TO 24 VAC	TO 24 VAC	TO 24 VAC	TO 24 VAC	TO 24 VAC
50	PE-10-2105	PE-10-6105	PE-10-5105	PE-10-7105	PE-10-9105
75	PE-10-2107	PE-10-6107	PE-10-5107	PE-10-7107	PE-10-9107

<b>FUSES</b>			
<b>TYPE CC</b>	<b>AMPS</b>	<b>STANDARD</b>	<b>TIME DELAY</b>
600 VOLT	1	PE-06-0001	N/A
MINI	2	PE-06-0002	PE-06-0035
	3	PE-06-0003	PE-06-0037
	4	PE-06-0004	PE-06-0039
	5	PE-06-0005	PE-06-0040
	6	PE-06-0006	PE-06-0041
	10	PE-06-0010	PE-06-0044
	15	PE-06-0015	PE-06-0046
	20	PE-06-0020	PE-06-0047
	25	PE-06-0025	PE-06-0048
	30	PE-06-0030	PE-06-0049

ENVIRO-TEC is a registered trademark of Johnson Controls, Inc. in the United States of America and other countries.  
Other trademarks used herein may be trademarks or registered trademarks of other companies.

Catalog: ET130.13-NOM3 (615) Supersedes ET130.13-NOM3 (708)  
© 2015 Johnson Controls, Inc. P.O. Box 423, Milwaukee, WI 53201 Printed in USA  
[www.enviro-tec.com](http://www.enviro-tec.com)

