



ENVIRO-TEC®

VERTICAL HI-RISE FAN COILS SERIES B

INSTALLATION, OPERATION & MAINTENANCE

Supersedes: ET115.24-NOM4 (315)

Form ET115.24-NOM4 (615)

**MODELS VHC/VHS/VHM VERTICAL HI-RISE
VHA/VHB TANDEM MASTER & TANDEM SLAVE**



IMPORTANT!

READ BEFORE PROCEEDING!

GENERAL SAFETY GUIDELINES

This equipment is a relatively complicated apparatus. During rigging, installation, operation, maintenance, or service, individuals may be exposed to certain components or conditions including, but not limited to: heavy objects, refrigerants, materials under pressure, rotating components, and both high and low voltage. Each of these items has the potential, if misused or handled improperly, to cause bodily injury or death. It is the obligation and responsibility of rigging, installation, and operating/service personnel to identify and recognize these inherent hazards, protect themselves, and proceed safely in completing their tasks. Failure to comply with any of these requirements could result in serious damage to the equipment and the property in

which it is situated, as well as severe personal injury or death to themselves and people at the site.

This document is intended for use by owner-authorized rigging, installation, and operating/service personnel. It is expected that these individuals possess independent training that will enable them to perform their assigned tasks properly and safely. It is essential that, prior to performing any task on this equipment, this individual shall have read and understood the on-product labels, this document and any referenced materials. This individual shall also be familiar with and comply with all applicable industry and governmental standards and regulations pertaining to the task in question.

SAFETY SYMBOLS

The following symbols are used in this document to alert the reader to specific situations:



Indicates a possible hazardous situation which will result in death or serious injury if proper care is not taken.



Identifies a hazard which could lead to damage to the machine, damage to other equipment and/or environmental pollution if proper care is not taken or instructions are not followed.



Indicates a potentially hazardous situation which will result in possible injuries or damage to equipment if proper care is not taken.



Highlights additional information useful to the technician in completing the work being performed properly.



External wiring, unless specified as an optional connection in the manufacturer's product line, is not to be connected inside the control cabinet. Devices such as relays, switches, transducers and controls and any external wiring must not be installed inside the micro panel. All wiring must be in accordance with ENVIRO-TEC's published specifications and must be performed only by a qualified electrician. ENVIRO-TEC will NOT be responsible for damage/problems resulting from improper connections to the controls or application of improper control signals. Failure to follow this warning will void the manufacturer's warranty and cause serious damage to property or personal injury.

CHANGEABILITY OF THIS DOCUMENT

In complying with ENVIRO-TEC's policy for continuous product improvement, the information contained in this document is subject to change without notice. ENVIRO-TEC makes no commitment to update or provide current information automatically to the manual or product owner. Updated manuals, if applicable, can be obtained by contacting the nearest ENVIRO-TEC Service office.

It is the responsibility of rigging, lifting, and operating/service personnel to verify the applicability of these documents to the equipment. If there is any question

regarding the applicability of these documents, rigging, lifting, and operating/service personnel should verify whether the equipment has been modified and if current literature is available from the owner of the equipment prior to performing any work on the chiller.

CHANGE BARS

Revisions made to this document are indicated with a line along the left or right hand column in the area the revision was made. These revisions are to technical information and any other changes in spelling, grammar or formatting are not included.

SAFETY CONSIDERATIONS

The equipment covered by this manual is designed for safe and reliable operation when installed, operated, and maintained within its' design specifications. To avoid personal injury or damage to equipment or property during installation, operation, and maintenance of this equipment, it is essential that these functions be performed by qualified, experienced personnel using good judgment and safe practices. See the following cautionary statements.



ELECTRICAL SHOCK HAZARDS. *All power must be disconnected prior to installation and servicing of this equipment. More than one power source may be present. Disconnect all power sources to avoid electrocution or shock injuries.*



MOVING PARTS HAZARDS. *Power must be disconnected from the motor and blower prior to opening access panels. Motors can start automatically, and more than one power source may be present. Disconnect all power and control circuits prior to servicing to avoid serious crushing or dismembering injuries.*



Electric resistance heating elements may start automatically. Disconnect all power and control circuits, and allow the elements to cool before servicing. Again, more than one power source may be present.



HOT PARTS HAZARDS. *Hot water and steam heating coils operate at temperatures that will cause severe burn injury. Some systems will continue to allow circulation of hot water, even with all control circuits deenergized. Before performing service at or near any heating coil, piping, or valve package component, disconnect all power and close all isolation valves, and allow the equipment to cool. As previously mentioned, more than one power source may be present.*



Check that the unit assembly and component weights can be safely supported by rigging and lifting equipment.



All assemblies must be adequately secured during lifting and rigging by temporary supports and restraints until equipment is permanently fastened and set in its final location.



All unit temporary and permanent supports must be capable of safely supporting the equipment's weight and any additional live or dead loads that may be encountered. All supports must be designed to meet applicable local codes and ordinances.



All fastening devices must be designed to mechanically lock the assembly in place without the capability of loosening or breaking away due to system operation and vibration.



Secure all dampers when servicing damper, actuator or linkages. Dampers may activate automatically, disconnect control circuits to avoid injury.



Protect adjacent flammable materials when brazing, Use flame and heat protection barriers where needed. Have fire extinguisher available and ready for immediate use.



Never wear bulky or loose fitting clothing when working on any mechanical equipment. Gloves should only be worn when required for proper protection from heat or other possible injury. Safety glasses or goggles should always be worn when drilling, cutting, or working with chemicals such as refrigerants or lubricants.



Never pressurize any equipment beyond specified test pressures. Always pressure test with some fluid or inert gas such as clear water or dry nitrogen on refrigeration systems to avoid possible damage or injury in the event of a leak or component failure during testing.



The manufacturer assumes no responsibility for personal injury or property damage resulting from improper or unsafe practices during the handling, installation, service, or operation of any equipment.

VH SERIES B FEATURES

SEE SECTION 6 - Dimensional Data FOR DIMENSIONAL DRAWINGS

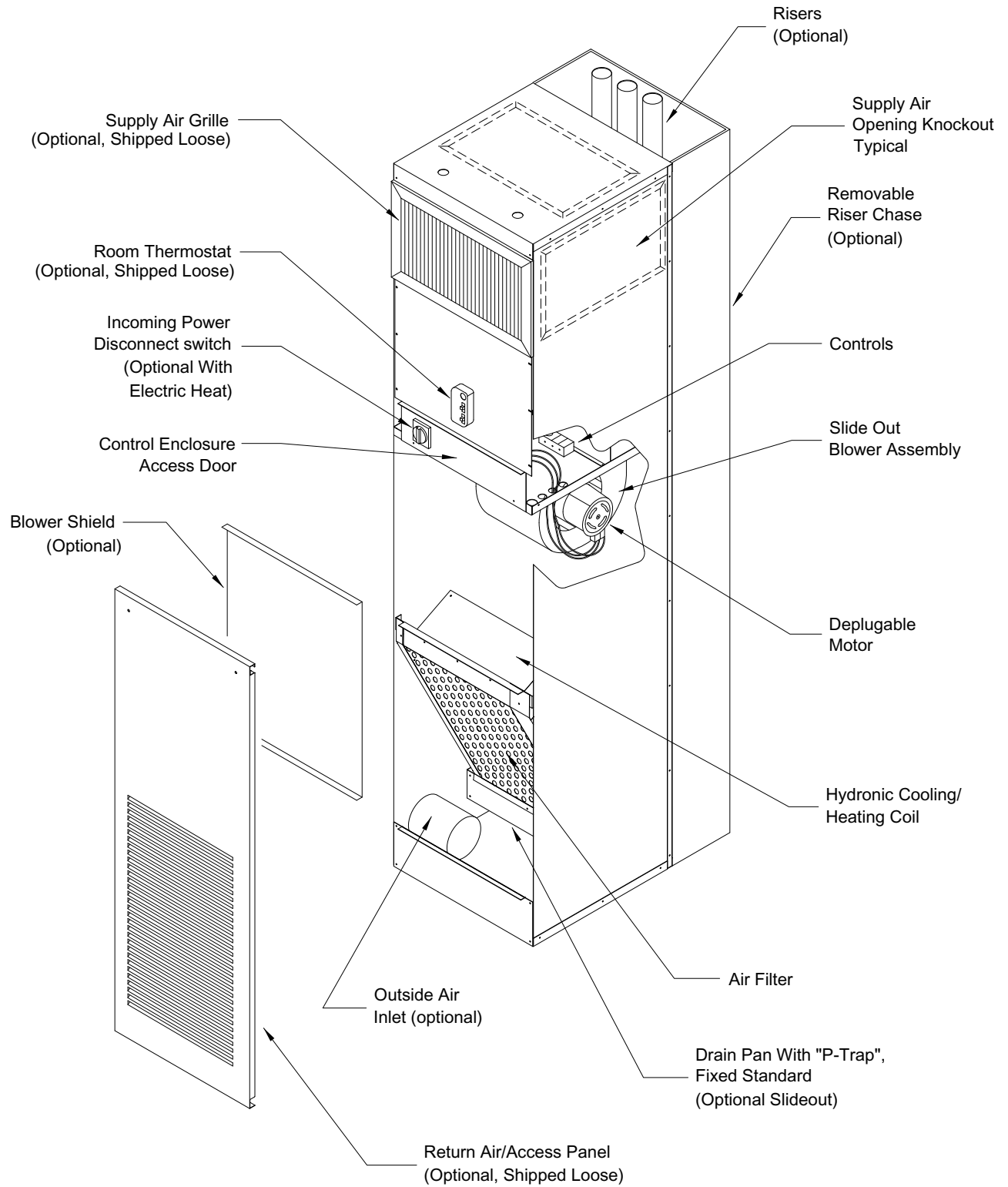

Note: Some optional items are included with other features.

TABLE OF CONTENTS

SECTION 1 - RECEIPT & INSTALLATION	11
Preface	11
Unpacking & Inspection	11
Ship Loose Items	11
Handling & Installation	12
Cooling/Heating Medium Connections	12
Flex Hose	14
Factory Installed Risers	14
Factory Furnished, Field Installed Risers	15
Field Furnished and Installed Piping or Risers	16
Riser Connection	16
Ductwork Connections	17
Dual Air Discharge Units	17
Field Reconfigurable Risers and Discharge Openings.....	18
Riser Reconfiguration	18
Discharge Opening Reconfiguration	18
Wall Framing	19
Tandem Master & Tandem Slave Unit Installation	19
Outside Air Connection	20
Manual Outside Air Damper	20
Motorized Outside Air Damper	20
Electrical Connections Shock / Electrical Hazards.....	20
Thermostats	21
 SECTION 2 - START-UP	 23
General	23
Cooling/Heating System	23
Air System Balancing	24
Water System Balancing	24
Controls Operation	24
Fan Coil EC Motor Control	25
G3 PWM Board	25
PWM Board Status LED	25
G3 PWM Status Descriptions.....	26
Adjusting EC Motor Speed.....	27
2 – 10 VDC Proportional Motor Control.....	29
EC Motor Troubleshooting Guidelines.....	32
Checking EC Wire Harnesses	35
EC Motor and Driver.....	35
Constant Airflow/Constant Torque EC Motors	35
Constant RPM EC Motors.....	36
Constant RPM EC Motor Driver Enable Jumper.....	37
ECM 3-Speed Constant Torque Motor Troubleshooting Guide	38
Procedure for Checking ECM Constant Torque Wiring Harnesses.....	39
ECM Constant Torque Motor Connections.....	39
ECM Constant Torque Motor Specifications.....	40
Wiring Diagrams.....	42

TABLE OF CONTENTS (CONT'D)

SECTION 3 - NORMAL OPERATION & PERIODIC MAINTENANCE	47
General	47
Motor/Blower Assembly	47
Coil	47
Electric Resistance Heater Assembly.....	47
Electrical Wiring & Controls	48
Valves & Piping	48
Filters, Throwaway	49
Drain	49
Optional Removable Drain Pan	49
Replacement Parts	49
 SECTION 4 - INSPECTION, INSTALLATION & START-UP CHECKLIST	 51
 SECTION 5 - TROUBLESHOOTING	 53
Troubleshooting Guide for Fan Coil Relay Board.....	56
 SECTION 6 - DIMENSIONAL DATA	 59
Vertical Hi-Rise Tandem Units	
VHA/VHB Installation Instructions	83
Receipt & Initial Installation	83
Temperature	87

LIST OF FIGURES

FIGURE 1 - Flex Hose Connections.....	13
FIGURE 2 - Ball Valve With Memory Stop.....	13
FIGURE 3 - Factory Installed Risers	14
FIGURE 4 - Factory Installed Risers, Master/Slave Configuration.....	15
FIGURE 5 - Factory Furnished, Field Installed Risers.....	15
FIGURE 6 - Factory Furnished, Field Installed Risers, Master/Slave.....	15
FIGURE 7 - Field Furnished and Installed Risers.....	16
FIGURE 8 - Field Furnished and Installed Risers Master/Slave.....	16
FIGURE 9 - Knockout Removal.....	18
FIGURE 10 - Critical Penetration Areas	19
FIGURE 11 - Outside Air Connection	20
FIGURE 12 - G3 PWM Board.....	25
FIGURE 13 - Program Mode (Configuration Switch 1 ON)	26
FIGURE 14 - Constant RPM and Constant Torque EC Motors Example Fan Calibration Curve	27
FIGURE 15 - Constant Airflow and Constant Torque EC Motors Example Fan Calibration Curve.....	27
FIGURE 16 - High Speed Adjust	28
FIGURE 17 - Medium Speed Adjust.....	28
FIGURE 18 - Low Speed Adjust	29
FIGURE 19 - Normal Three Speed Operation.....	29
FIGURE 20 - Mode to 2–10 VDC Proportional Control	30
FIGURE 21 - Max Speed Adjust.....	30
FIGURE 22 - Min Speed Adjust.....	31
FIGURE 23 - Normal 2 – 10 VDC Speed Control.....	31
FIGURE 24 - Constant CFM/Constant Torque EC Motors (1/3 HP Shown).....	35
FIGURE 25 - Constant CFM/Constant Torque EC Motor Driver.....	35
FIGURE 26 - Constant RPM EC Motor (1/4 HP Shown).....	36
FIGURE 27 - Constant RPM EC Motor Driver.....	36
FIGURE 28 - Constant RPM EC Driver EC Motor Enable Connector.....	37
FIGURE 29 - Motor Power and Signal Connectors	39
FIGURE 30 - Example Wiring Diagram 1	42
FIGURE 31 - Example Wiring Diagram 2	44
FIGURE 32 - Motor/Blower Assembly	47
FIGURE 33 - Electric Heat.....	48
FIGURE 34 - Drain Pan Removal.....	49
FIGURE 35 - Fan Coil Relay Board with Motor Power Connections.....	56
FIGURE 36 - Fan Coil Relay Board (Current)	57
FIGURE 37 - Fan Coil Relay Board (Obsolete).....	57
FIGURE 38 - Model VHM, Vertical Concealed Master High Rise, FCU, 88" Cabinet	59
FIGURE 39 - Model VHS, Vertical Concealed Slave High Rise, FCU, 88" Cabinet	60
FIGURE 40 - Model VHA/VHB, Vertical Hi-Rise Tandem Fire Rated and Non-Fire Rated, FCU Combinations, 88" Cabinets	61
FIGURE 41 - Model VH, Vertical Concealed High Rise Fan Coil Unit with 79" Cabinet.....	63
FIGURE 42 - Model VHM, Vertical Concealed Master High Rise Fan Coil Unit with 79" Cabinet.....	64
FIGURE 43 - Model VHS, Vertical Concealed Slave High Rise Fan Coil Unit with 79" Cabinet	65
FIGURE 44 - Model VHA/VHB, Vertical Hi-Rise Fire Rated and Non-Fire Rated FCU Combinations, 79" cabinets	66
FIGURE 45 - Model VH, Vertical High Rise Coil Unit, Aluminum Discharge Grille.....	68
FIGURE 46 - Model VHC/VHM/VHA Vertical High Rise Fan Coil Unit Arrangement Designations.....	69

LIST OF FIGURES (CONT'D)

FIGURE 47 - Model VHC w/o Risers & VHS/VHB Vertical High Rise Fan Coil Units, Unit Arrangement Designations	70
FIGURE 48 - Model VH Vertical High Rise Coil Unit Outside Inlet Dimensions	71
FIGURE 49 - Model VHM/VHA/VHC Tandem Master & Tandem Slave Unit Configuration Fan Coil Unit.....	72
FIGURE 50 - Assembly Instructions Return Panel with Latches, Quick Opening or Tamper Proof, Model VHC/VHM/VHS High Rise FCU	73
FIGURE 51 - Preparation Instructions for Model VHC/VHM Vertical High Rise FCU "Ship Loose" Riser Assemblies	74
FIGURE 52 - Full Louvered Aluminum Return Air/Wall Panel Model VH Vertical High Rise Fan Coil Unit	75
FIGURE 53 - Model VH Vertical High Rise Fan Coil Unit Standard Surface Mount Wall Panel.....	76
FIGURE 54 - Recessed Wall Panel Model VH Vertical High Rise Fan Coil Unit.....	77
FIGURE 55 - Model VH Vertical High Rise Fan Coil Unit Standard Return Wall Panel with ADA Thermostat.....	78
FIGURE 56 - Suggested Riser Floor Openings VHC & VHM.....	81
FIGURE 57 - Riser Terminology, Model VHC, VHM, VHA Units.....	82
FIGURE 58 - Standard Installation	84
FIGURE 59 - Alternate Installation.....	84
FIGURE 60 - Mounting Details	85

LIST OF TABLES

TABLE 1 - G3 Status LED Definition	25
TABLE 2 - EC Motor Troubleshooting Guidelines	32
TABLE 3 - Signal Connector	36
TABLE 4 - Power Connector	36
TABLE 5 - CON1, Power Input.....	36
TABLE 6 - CON502 (if present), Programming Connector.....	36
TABLE 7 - CON302, PWM Signal Input	36
TABLE 8 - CON503 (if present), Motor Enable Input	37
TABLE 9 - CON202, Feedback from EC Motor Hall Sensor	37
TABLE 10 - CON201, Output Power to Motor.....	37
TABLE 11 - ECM Constant Torque Motor Specific Troubleshooting Guidelines	38
TABLE 12 - The ECM Constant Torque Motor Power Wiring Harness	39
TABLE 13 - The Standard ECM Constant Torque Motor Signal Wiring Harness (White Plug)	40
TABLE 14 - The High Static ECM Constant Torque Motor Signal Wiring Harness (Red Plug)	40
TABLE 15 - ECM Constant Torque Motor Part Numbers	40
TABLE 16 - Motor Signal Tap Specifications.....	40
TABLE 17 - General ECM Constant Torque Motor Specifications	40
TABLE 18 - Discharge Register Performance Data, VH Standard FCU 88" Cabinet, Single and Double Supply .	79
TABLE 19 - Discharge Register Performance Data, VH Standard FCU 79" Cabinet, Single and Double Supply .	80
TABLE 20 - SI Metric Conversion.....	87

THIS PAGE INTENTIONALLY LEFT BLANK

SECTION 1 - RECEIPT & INSTALLATION

PREFACE

ENVIRO-TEC fan coils represent a prudent investment which can, with proper installation, operation, and regular maintenance, give trouble-free operation and long service.

Equipment is initially protected under the manufacturers' standard warranty; however, this warranty is provided under the condition that the steps outlined in this manual for initial inspection, proper installation, regular periodic maintenance, and everyday operation of the equipment be followed in detail. This manual should be fully reviewed in advance of any actual work being done on the equipment. Should any questions arise, please contact your local Sales Representative or the factory BEFORE proceeding.

The equipment covered by this manual is available with a vast variety of options and accessories. Consult the approved unit submittal, order acknowledgement, and other manuals for details on the options and accessories provided with the equipment on each project.

UNPACKING & INSPECTION

All units are carefully inspected at the factory throughout the manufacturing process under a detailed quality assurance program. All factory furnished major components and subassemblies are carefully tested for proper operation and verified to be in full compliance with the customer order and quality assurance documents.

Each unit is then carefully packaged for shipment to avoid damage during normal transport and handling. The equipment must be stored in a dry place in the proper orientation as marked on the packaging.

All shipments are made F.O.B. factory and it is the responsibility of the receiving party to inspect the equipment upon arrival. Any obvious damage to the packaging and/or its contents should be recorded on the bill of lading and a claim should be filed with the freight carrier.

After determining the condition of the unit's exterior, carefully remove each unit from the packaging and inspect for hidden damage. At this time, check to make sure that "ship loose" items such as grilles, decorator panels, and thermostats are accounted for. Any hidden damage should be recorded and immediately reported to the carrier, and a claim filed as before. In the event a claim for shipping damage is filed, the unit, shipping package, and all packing must be retained for physical inspection by the freight carrier. All equipment should be stored in the factory shipping package with internal packing in place until installation.

A series of rigorous leak tests are performed on all of the piping installed in this equipment to ensure piping integrity. Because this equipment may be shipped with factory supplied external riser piping, it is necessary for the receiving inspector to carefully inspect this piping for signs of shipping damage. If damage is present, a claim must be filed with the freight carrier.

At the time of receipt, the equipment type and arrangement should be verified against the order documents. Should any discrepancy be found, the local Sales Representative should be notified immediately so that the proper action may be instituted. Should any question arise concerning warranty repairs, the factory must be notified BEFORE any corrective action is taken. Where local repairs or alterations can be accomplished, the factory must be fully informed as to the extent and expected cost of those repairs before work is begun. Where factory operations are required, the factory must be contacted for authorization to return equipment and a Return Authorization Number will be issued. Unauthorized return shipments of equipment and shipments not marked with an authorization number will be refused. In addition, the manufacturer will not accept any claims for unauthorized expenses.

SHIP LOOSE ITEMS

Several components are shipped loose for field installation. These may include: thermostat, return air access panel, return air access panel fasteners, discharge grille(s), risers (optional). These parts are shipped loose to offer protection against shipping and job-site damage. Refer to packing slip.

HANDLING & INSTALLATION

While all equipment is designed and fabricated of sturdy construction and may present a rugged appearance, great care must be taken to assure that no force or pressure be applied to the coil, risers, piping or drain stub-outs during handling. Do not use the risers for lifting the unit. Also, depending on the options and accessories, some units could contain delicate components that may be damaged by improper handling. Wherever possible, all units should be maintained in an upright position and handled by the exterior casing, with no impact forces applied that may damage internal components or painted surfaces.

The equipment covered in this manual IS NOT suitable for outdoor installations. The equipment should never be stored or installed where it may be subjected to a hostile environment such as rain, snow, extreme temperatures, or hazardous chemicals.

During and after installation, special care must be taken to prevent foreign material such as paint, plaster, and drywall dust from being deposited in the drain pan, electric heater, motor and blower wheels. Failure to do so may have serious adverse effects on unit operation and in the case of the heater, motor and blower assembly, may result in immediate or premature failure. All manufacturers' warranties are void if foreign material is allowed to be deposited on the heater, motor or blower wheels of any unit. Some units and/or job conditions may require some form of temporary covering during construction.

Condensate pan is internally sloped toward drain connection. Make assurance that unit is level and plumb. Level the unit to insure proper coil operation and condensate drainage. After units are positioned and risers centered in pipe chase, plumb the unit in two directions, using unit casing as a reference. Avoid any interference with wiring, coil, or coil connections, drain pan, and structural components inside the cabinet while using bolts or lag screws to anchor the unit to building. See *Figure 10 on page 19* for critical penetration areas.

After mounting the unit, it is then ready for the various service connections such as water, drain and electrical. At this time it should be verified that the proper types of service are actually provided to the unit. On those units requiring chilled water and/or hot water,

the proper line size and water temperature should be available to the unit. The electrical service to the unit should be compared to the unit nameplate to verify compatibility. The routing and sizing of all piping, and the type and sizing of all wiring and other electrical components such as circuit breakers, disconnect switches, etc. should be determined by the individual job requirements and should not be based on the size and/or type of connection provided on the equipment. All installations should be made in compliance with all governing codes and ordinances. Compliance with all codes is the responsibility of the installing contractor.



For seismic certified installation, reference the seismic installation document.

COOLING/HEATING MEDIUM CONNECTIONS



Toxic residues and loose particles resulting from manufacturing and field piping techniques such as joint compounds, soldering flux, and metal shavings may be present in the unit and the piping system. Special consideration must be given to system cleanliness when connecting to solar, domestic or potable water systems.

Submittals and Product Catalogs detailing unit operation, controls, and connections should be thoroughly reviewed BEFORE beginning the connection of the various cooling and/or heating mediums to the unit.

All accessory valve packages should be installed as required, and all service valves should be checked for proper operation.

If coil and valve package connections are made with "sweat" or solder joint, care should be taken to assure that no components in the valve package are subjected to a high temperature which may damage seals or other materials. Many two-position electric control valves, depending on valve operation, are provided with a manual-opening lever. This lever should be placed in the "open" position during all soldering or brazing operations. Solder joints with Sil-fos[®], phos-copper, or similar high temperature alloy. Do not use soft solder.

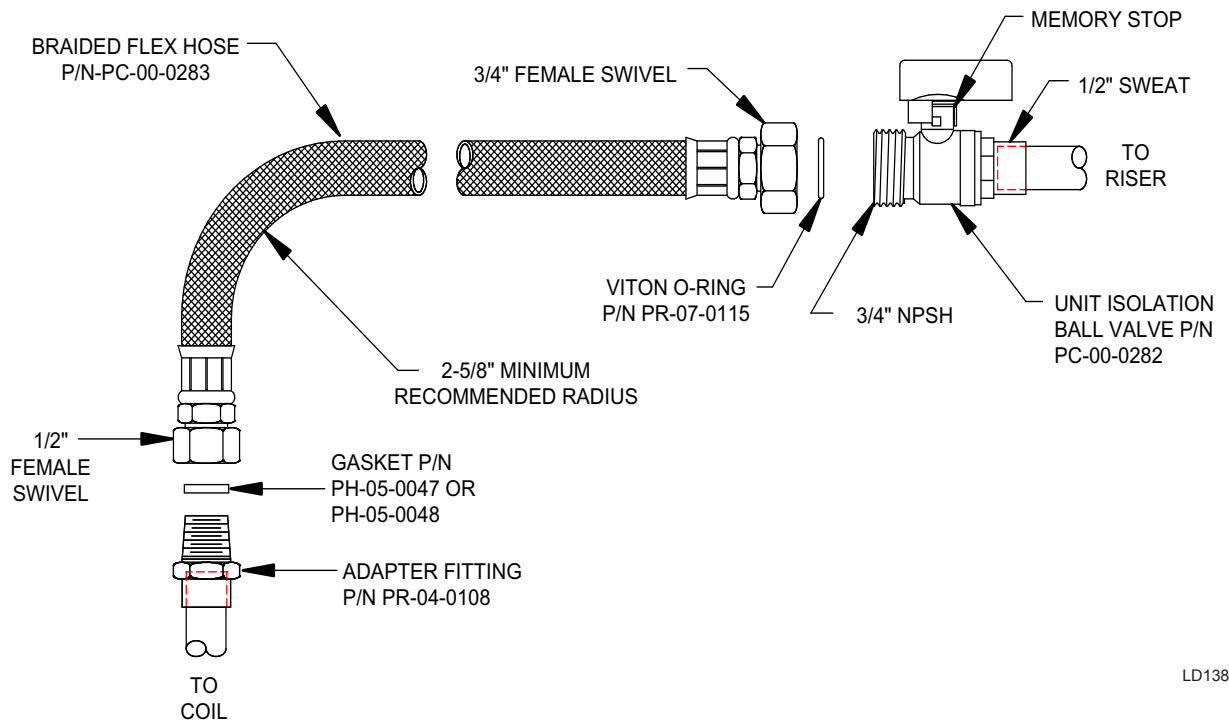

LD13870

FIGURE 1 - FLEX HOSE CONNECTIONS

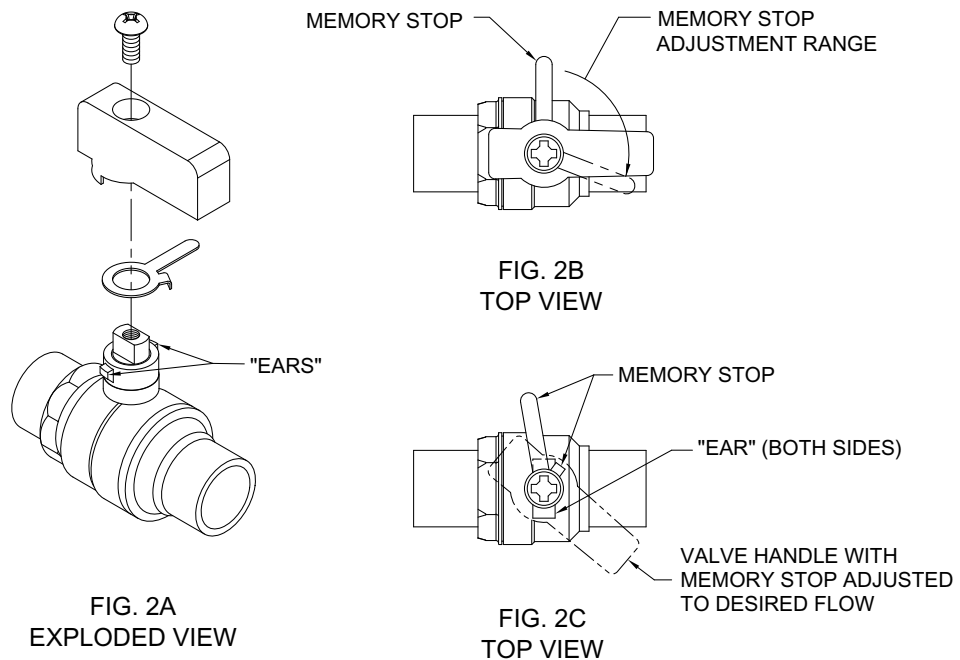

NOTE:
Valve package isolation valve shown,
typical for riser shut off valve.

TO REGULATE FLOW (FIG. 2C):
STEP 1. SET VALVE TO DESIRED FLOW.
STEP 2. LOOSEN SCREW AT THE TOP OF VALVE.
STEP 3. TURN MEMORY STOP TO "EAR" ON VALVE BODY.
STEP 4. TIGHTEN SCREW AT TOP OF VALVE.

LD13871

FIGURE 2 - BALL VALVE WITH MEMORY STOP

FLEX HOSE

All Vertical Hi-Rise and Tandem Master & Tandem Slave units use Kevlar reinforced braided stainless steel flexible hoses for all water piping between the coil and the risers or field piping. This factory piping includes two ball valves per coil, with memory stop. These hoses are designed with swivel connections on both ends, and require either a gasket or O-ring for positive sealing. See *Figure 1 on page 13* for connection details.

These hoses are designed to provide for riser movement due to thermal expansion, and allow for quick, easy coil removal through the use of the swivel connections.

During transit, vibration may cause a connection to loosen. Therefore, all threaded connections must be checked during unit installation. Any fitting that is loose must be tightened. The stationary side of any swivel connection must be prevented from twisting during tightening by the use of a “backup” wrench. Pressure test all joints before applying water.

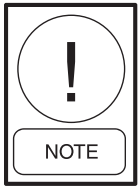

Some hose-to-coil joints are furnished with a removable vulcanized fiber gasket. This gasket (Part No. PH-05-0047) must be replaced each time the joint is broken. Later model units have a hose-to-coil joint with a black EDPM gasket (Part No. PH-05-0048). This gasket is re-useable, but may be replaced should it become damaged and no longer seal.

FACTORY INSTALLED RISERS

Units provided with factory installed water and drain risers include fully insulated risers as specified per order. The flex hose and ball valve described above is assembled to the riser and pressure tested at the factory. Each unit is configured for a specific location in the building, and is marked with that location by room number, floor, riser number, or other identification as specified per order.

Units provided with factory installed drain risers are supplied with “full height” drain risers that extend 3” above the top of the unit, and include the standard “swaged” section at the top. Field piping and venting of the drain riser must be furnished and installed by others.

Factory installed risers are strapped to the unit for shipment to prevent damage during transit. These shipping straps must be removed at installation to allow movement of the risers to assure proper alignment.

See *Figure 3 on page 14* and *Figure 4 on page 15* for details.



At no time should a unit be lifted, moved, or otherwise handled by the risers.

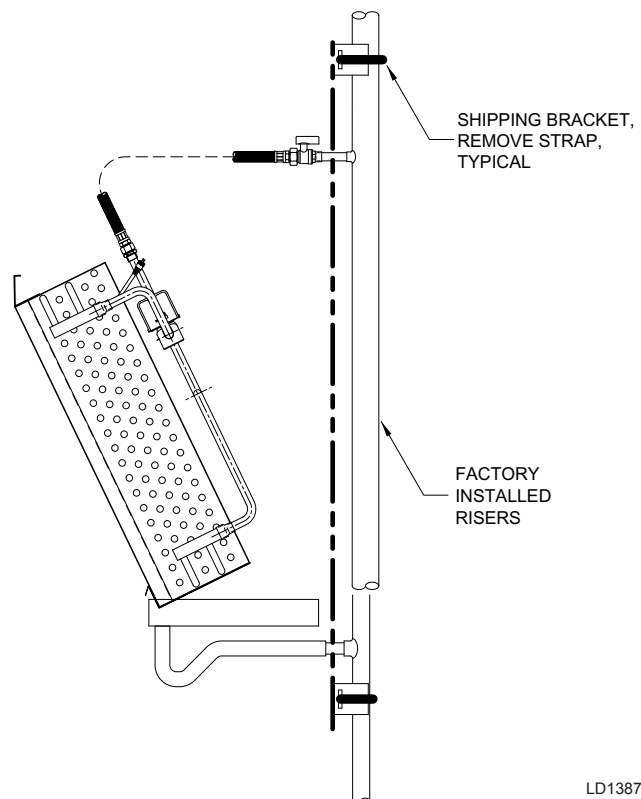

LD13872

FIGURE 3 - FACTORY INSTALLED RISERS

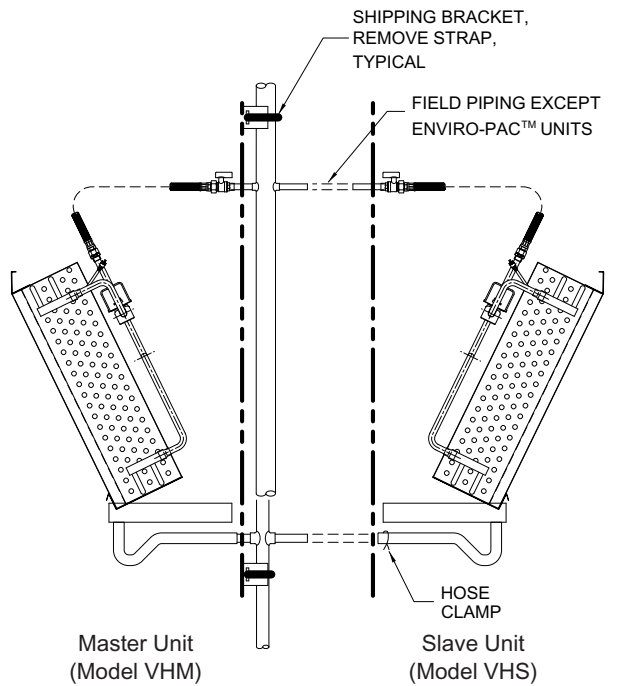

LD13873

FIGURE 4 - FACTORY INSTALLED RISERS, MASTER/SLAVE CONFIGURATION

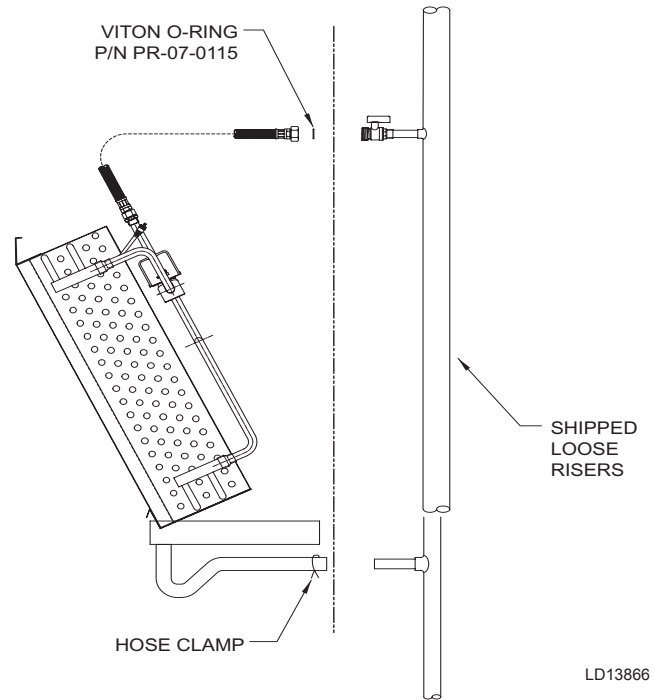

LD13866

FIGURE 5 - FACTORY FURNISHED, FIELD INSTALLED RISERS

FACTORY FURNISHED, FIELD INSTALLED RISERS

Units provided with factory furnished, field installed water and drain risers include fully insulated risers as specified per order, which are shipped separately for installation on the job prior to receipt of the units. The ball valve previously described is assembled to the riser and pressure tested at the factory. The risers are packaged as a “kit” for a specific location in the building, and each “kit” is marked with that location by room number, floor, riser number, or other identification as specified per order.

Riser “kits” that include drain risers are supplied with “full height” drain risers that extend 3” above the top of the unit, and include the standard “swaged” section at the top, similar to factory installed riser sets. Field piping and venting of the drain riser must be furnished and installed by others.

See Figures 5 and 6 on page 15 for details.

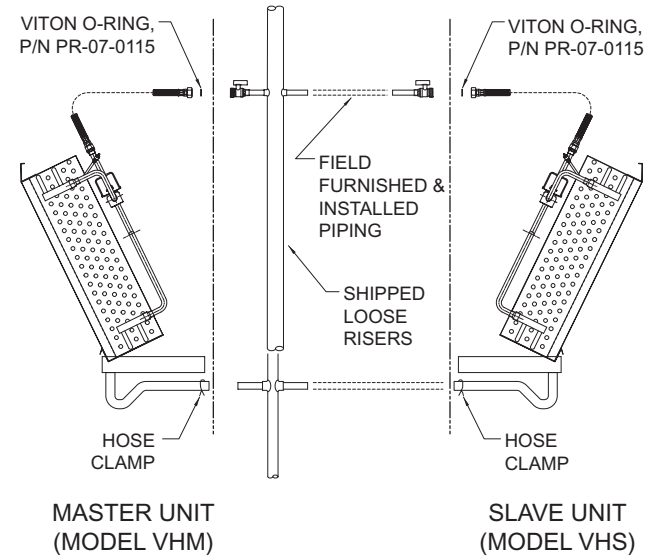

LD13867

FIGURE 6 - FACTORY FURNISHED, FIELD INSTALLED RISERS, MASTER/SLAVE



Field installed risers MUST be installed with the proper unit connection height and orientation to allow for correct unit installation at a later date. Swage is always oriented up. Refer to unit dimensional drawings.

FIELD FURNISHED AND INSTALLED PIPING OR RISERS

Units provided for field furnished and installed water and drain piping or risers include the flex hose and ball valve assemblies previously described. These hose and valve assemblies include a stub of copper tube for field connection to the unit piping. The factory hose and valve assemblies are marked by connection type and retracted inside the unit for shipment. Do not braze the pipe stub without opening the ball valve and disconnecting the hose. Riser stub out should slope down slightly away from the riser. This prevents condensation from dripping at the bottom of a riser column.

See *Figure 7 on page 16* for details.



Field fabricated/installed piping and risers MUST be installed with the proper unit connection height and orientation to allow for correct unit installation at a later date. Refer to unit dimensional drawings.

RISER CONNECTION

Do not rigidly attach risers to this equipment. Risers must be free to move with thermal expansion and contraction. Units and risers are designed to accommodate a maximum of 3" (1-1/2" up and 1-1/2" down) total vertical movement. To achieve this range of movement, the risers must be installed according to the conditions outlined below. If the total combined riser expansion will exceed 3", additional expansion compensation, such as loops and expansion joints, or alternate riser anchoring techniques must be field furnished and installed.

Factory furnished risers are designed with a "swage" or socket in the top to accommodate 2" of tailpiece insertion from the riser above. The riser configuration, when combined with the required length as provided by the customer, is designed to position the riser-to-unit stub out piping at the vertical center of the riser slot in the unit casing. See unit submittal drawings for dimensional details. Due to building construction variations, some risers may require cutting or lengthening to correctly position the riser. Any field modifications are the responsibility of the installer.

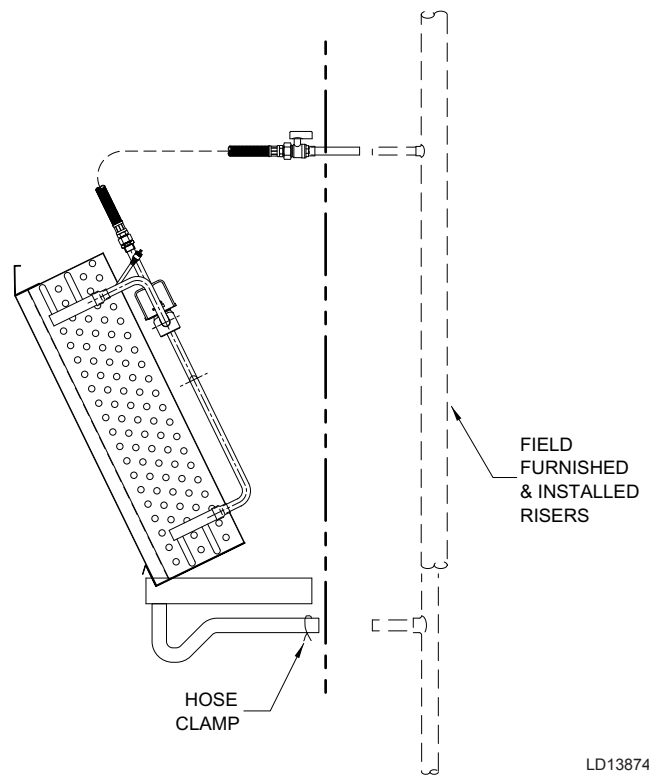

LD13874

FIGURE 7 - FIELD FURNISHED AND INSTALLED RISERS

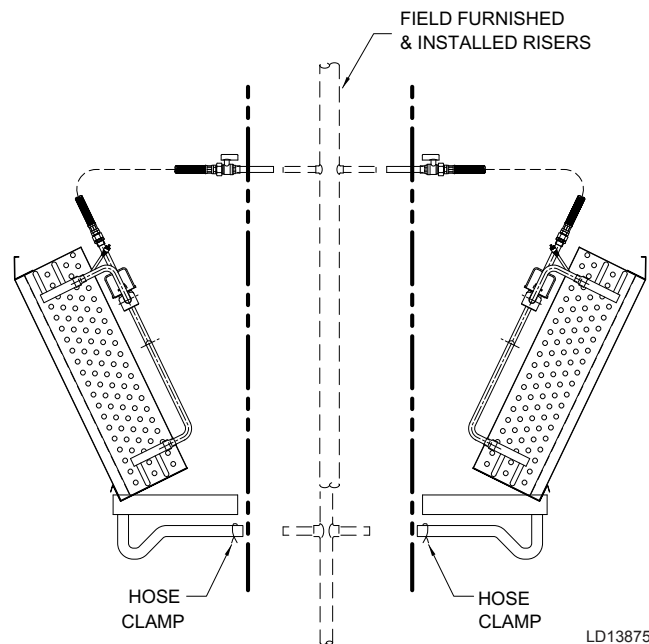

LD13875

FIGURE 8 - FIELD FURNISHED AND INSTALLED RISERS MASTER/SLAVE

After all connections are completed, and prior to insulating and furring-in of any riser or piping connections, the system should be tested for leaks. Since some components are not designed to hold pressure with a gas, hydronic systems should be tested with clear water. Care should be taken to completely drain the system, or otherwise protect it from freezing in cold weather.



Standard unit operating pressure is 300 psig maximum. Field test pressure must not exceed 400 psig maximum. Some optional or special unit piping components may have lower pressure ratings than the standard unit. All valve and piping component pressure ratings must be verified before applying test pressure to the unit.



All water coils and unit piping must be protected from freezing after initial filling with water. Unit coils and piping may still hold enough water to cause damage when exposed to freezing temperatures, even after the system is drained.

In the event that leaking or defective components are discovered, the Sales Representative must be notified BEFORE any repairs are attempted. All leaks should be repaired before proceeding with installation.

After all risers and piping are installed and pressure tested, all riser joints must have the insulation joint sealed and all other piping must be insulated in compliance with the project specifications. All chilled water risers, piping, and valves must be insulated or located over a drain pan, to prevent damage from condensation. This includes factory and field piping inside the unit cabinet.

The drain should always be connected and piped to an acceptable disposal point. For proper moisture carry-off, the drain piping should be sloped away from the unit at least 1/8" per foot. A drain trap is integral to the unit and is necessary for odor containment. The drain riser and piping must be installed to avoid pinching or kinking the unit drain tube.

Any required piping or riser penetration fire blocking is the responsibility of the installer. All penetrations for piping and risers should be sealed with materials and techniques suitable for all governing codes and ordinances.

DUCTWORK CONNECTIONS

All ductwork and/or supply and return grills should be installed in accordance with the project plans and specifications. If not included on the unit or furnished from the factory, supply and return grilles should be provided as recommend in the product catalog.

All units must be installed in non-hazardous areas. Zero clearance to combustible materials is allowed.

Units provided with outside air for ventilation should have some form of low temperature protection to prevent coil freeze-up. This protection may be any of several methods such as a low temperature thermostat to close the outside air damper or a preheat coil to temper the outside air before it reaches the unit. It is recommended that outside air is pretreated to regulate its temperature and humidity ratio

It should be noted that none of these methods would adequately protect a coil in the event of power failure. The safest method of freeze protection is to use glycol in the proper percent solution for the coldest expected air temperature.

Flexible duct connections should be used on all air handling equipment. All ductwork and insulation should be installed to allow proper access to all components for service and repair such as filters motor/blower assemblies, etc.

Dual Air Discharge Units

All dual discharge units are provided with a sight and sound baffle in the discharge plenum area (except top discharge units). It is recommended that a discharge grille with a damper be provided in one of the discharge locations to aid in air balancing. Dual discharge units with top discharge must be provided with a field supplied damper in the top discharge duct.



Do not inhibit inlet or outlet connections. Quickly turning off the inlet or rapid reduction in ductwork can cause system effects that impact airflow. Reductions in airflow can cause electric heaters to overheat, condensation to form, or other unintended consequences, which can result in injury, property damage, equipment damage, as well as void factory warranty.

FIELD RECONFIGURABLE RISERS AND DISCHARGE OPENINGS

Riser Reconfiguration

Vertical Hi-Rise units are furnished with riser slot “knockouts” in the casing back and both sides. Should it be necessary to relocate risers in the field, the water risers may be disconnected at the swivel joint on the riser isolation valve, and removed from the unit. The drain riser may be removed by moving the drain tube hose clamp and removing the riser tube from the drain hose.

The water riser slot “knockouts” may be removed by clipping the “tabs” to separate the inner portion of the knockout. See *Figure 9 on page 18* for details. After opening the riser slot, make a vertical slit in the cabinet insulation with a sharp utility knife. This slit must be centered left to right, and full height in the slot. The water riser may now be re-installed at the desired location by inserting the valve through the new opening. Insert the valve through the opening with care to avoid damage to the cabinet insulation. Make sure that the swivel joint O-ring is undamaged, and re-attach the hose to the valve with the O-ring in place. Replacement O-rings (Part No. PR-07-0115) may be ordered through the parts department.

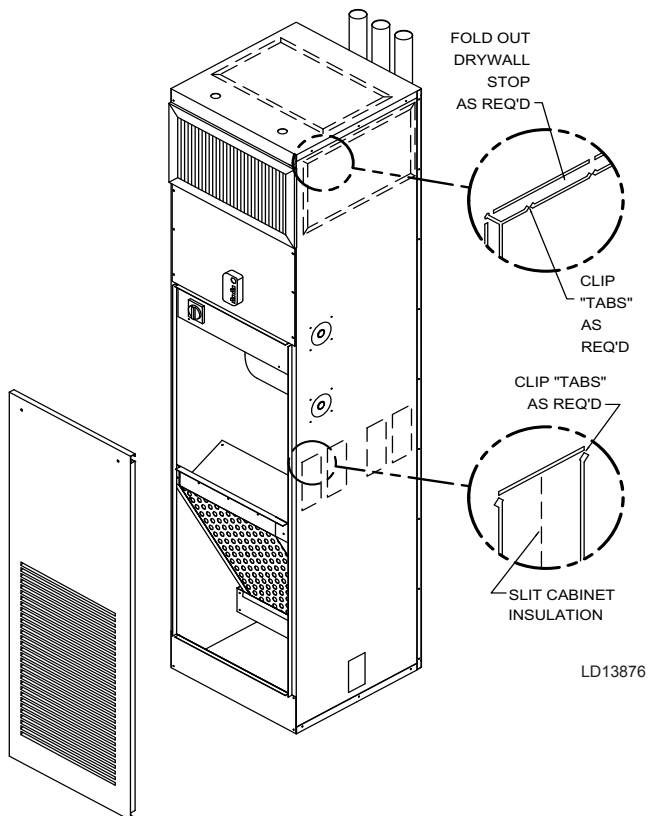

LD13876

FIGURE 9 - KNOCKOUT REMOVAL

After relocating all the risers, pressure test the joints to assure system integrity.

The drain riser slot is already present on the back, left and right sides. To install the drain riser, insert the riser tube into the unit and connect the drain hose using the hose clamp preciously removed.

After all the risers have been relocated, inspect the cabinet insulation where the risers were removed, and repair any insulation damage before starting the unit and cover unused openings.

DISCHARGE OPENING RECONFIGURATION

Vertical Hi-Rise and Tandem Master & Tandem Slave units are furnished with discharge opening “knockouts” in all four sides and the top. Should it be necessary to reconfigure a unit for a different discharge arrangement than originally provided, the new discharge opening may be created by clipping the tabs of the desired opening to remove the inner portion of the “knockout”. The side flanges may then be folded out to provide the drywall stops for the opening. See *Figure 9 on page 18* for details.

After the new opening is created, the cabinet insulation must be trimmed out, and the edges of the insulation should be coated with duct board adhesive or appropriate liner tape to prevent erosion into the airstream.

Any unused discharge openings must have the drywall stops bent back flush with the unit casing. The opening must then be covered with an insulated plate. Any cover plates and insulation must be provided and installed by others.

Relocating a discharge opening on a double discharge unit may require removal or relocation of any factory provided sight and sound baffle. Consult the factory for details on requirements and relocation of sight and sound baffles.

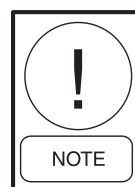

Size 10 and 12 units factory furnished with double discharge do not have discharge “knockouts” to allow field conversion to a single discharge. Consult the factory for details.

The manufacturer assumes no responsibility for undesirable system operation due to improper field design, equipment or component selection, and/or installation of ductwork, grilles, and other related components.

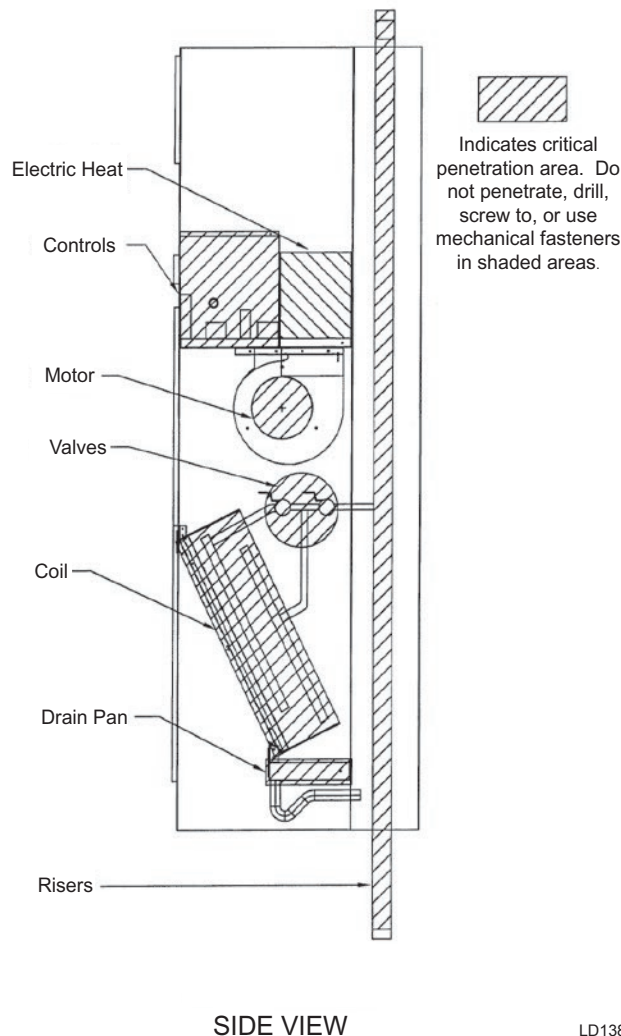

FIGURE 10 - CRITICAL PENETRATION AREAS

WALL FRAMING

All wall framing is the responsibility of others. The Vertical Hi-Rise and Tandem Master & Tandem Slave unit casing is designed to be concealed by a finished wall or enclosure that is installed in the field by others. This enclosure may be a framed structure with gypsum board or other material covering as selected by others. Where desired, the gypsum board or paneling may be applied directly to the unit casing. If the direct application method is used, care must be taken when installing the fasteners so as not to damage any internal components. See *Figure 10 on page 19* for critical penetration areas.

Due to factory manufacturing tolerances and jobsite construction variations, some unit casing surface conditions may exist that could require additional framing or shimming of the finished wall surface. **ALL WORK REQUIRED TO ACHIEVE THE DESIRED FINISHED WALL SURFACE CONDITION IS THE RESPONSIBILITY OF OTHERS.**

1. Attaching fasteners should be no longer than necessary to provide proper grip.
2. Do not locate fasteners where they could penetrate coils, risers, piping, electrical enclosures or other components.
3. Do not locate fasteners where they would pose a safety hazard during access or service on any internal components.
4. Do not locate fasteners where they would impede the access or removal of any internal component.
5. Verify that all enclosure attachment points are located properly and do not pose any safety hazards or damage any internal components before bringing the enclosure surface to finished condition (e.g., finish drywall or apply wall covering).

TANDEM MASTER & TANDEM SLAVE UNIT INSTALLATION

(See *SECTION 6 - Dimensional Data* for details)

Tandem Master & Tandem Slave units are shipped as a factory assembled pair and are intended for installation with the space separating the units to be included in the wall between the units. Tandem Master & Tandem Slave units are available with fire rated and non-fire rated construction.

Non-fire rated unit pairs may be installed as required to achieve the finished wall configuration desired. Wall framing and drywall application should be accomplished as noted above.

Fire rated unit pairs are designed to be installed with the space between the units becoming part of a fire rated wall usually used to separate specific occupancies. These unit pairs must be installed according to the procedure shown on Tandem Master & Tandem Slave Installation Instructions to maintain the fire rating for the unit.

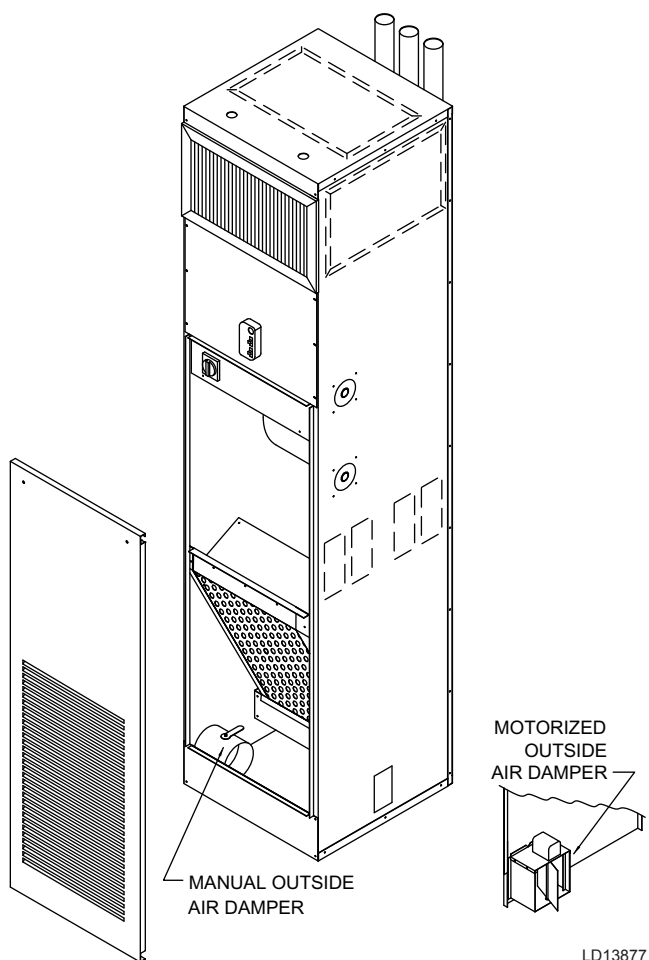

FIGURE 11 - OUTSIDE AIR CONNECTION

OUTSIDE AIR CONNECTION

The optional 6" diameter round outside air connection is provided with either a round butterfly manual damper, or a rectangular motorized damper assembly, for outside air control. See *Figure 11 on page 20* for details. Installation of outside air duct connections may require installation of a vapor barrier between the unit and the wall, and may require freeze protection control devices. These components must be supplied and installed by others as required. It is recommended that all outside air be pretreated to regulate its temperature and humidity ratio.

MANUAL OUTSIDE AIR DAMPER

The manual outside air damper may be adjusted by loosening the wing nuts on the top and bottom, and setting the adjustment lever to the required position for the desired amount of outside air. The wing nuts are then tightened to lock the damper in place.

MOTORIZED OUTSIDE AIR DAMPER

The standard motorized outside air damper is factory wired to open the damper when the fan is operating. Other damper operating sequences are available. See individual order documents to verify actual damper operation.

The motorized outside air damper is factory set to drive from full closed to full open. The damper may be adjusted in the field to set the desired amount of outside air by the following steps:

1. Loosen the set screw in the damper actuator set collar and turn on all power and set all controls to call for full outside air. This should drive the damper actuator to the "full open" position.
2. Manually position the damper blade to achieve the desired amount of outside air.
3. Tighten the set screw to lock the damper blade to the actuator set collar.
4. Disconnect power or set controls to de-energize the outside air, and verify that the damper drives to the "closed" position.
5. Re-energize the outside air and verify that the damper returns to the position set in Step 2.

ELECTRICAL CONNECTIONS SHOCK / ELECTRICAL HAZARDS

The unit nameplate lists the unit electrical characteristics such as the required supply voltage, fan and heater amperage, unit minimum circuit ampacity, and maximum overcurrent protective device. The unit-wiring diagram shows all unit and field wiring. Since each project is different and each unit on a project may be different, the installer must be familiar with the wiring diagram and nameplate on the unit **BEFORE** beginning any wiring. Provide for adequately sized fuse, circuit breaker or disconnect means as applicable to meet local and national electrical codes. All electrical connections should be checked for tightness prior to startup.

All components furnished for field installation, by either the factory or the controls contractor should be located and checked for proper function and compatibility. All internal components should be checked for shipping damage and any loose connections should be tightened to minimize problems during startup.

Any devices such as fan speed switches or thermostats that have been furnished from the factory for field installation must be wired in strict accordance with the applicable wiring diagrams. Failure to do so could result in personal injury or damage to components and will void all manufacturers' warranties. Refer to the diagram within unit.

THERMOSTATS

Various types of thermostats are available for this unit. Unit surface mounted thermostats are provided with a drywall mud ring for field mounting. The mud ring may be located on the unit front or either side as appropriate in the field. For remote mounted thermostats, the mud ring should be removed from the unit and re-installed on the thermostat mounting box, or discarded as necessary. Unit surface mounted thermostats are provided with a plug assembly for easy connection.

The plug is polarity specific and connects only in one direction. Remote thermostats must be field wired to unit's connection points as indicated on the unit's wiring diagram.

The fan motor(s) should never be controlled by any wiring or device other than the factory furnished switch or thermostat/switch combination, without factory authorization.

All field wiring should be done in accordance with governing codes and ordinances. Any modification of the unit wiring without factory authorization will result in voiding of all factory warranties and will nullify any agency listings.

The manufacturer assumes no responsibility for any damages and/or injuries resulting from improperly field installed or wired components.

THIS PAGE INTENTIONALLY LEFT BLANK

SECTION 2 - START-UP

GENERAL

Before beginning any start-up operation, the start-up personnel should familiarize themselves with the unit, options and accessories, and control sequence to understand the proper system operation. All personnel should have a good working knowledge of general start-up procedures and have the appropriate start-up and balancing guides available for consultation.

The building must be completely finished including doors, windows, and insulation. All internal walls and doors should be in place and in the normal position. In some cases the interior decorations, curtains and furniture may influence overall system performance by blocking return or supply air openings. The entire building should be as complete as possible before beginning any system balancing. Operation of the unit during construction is not recommended since construction dust will foul filters and coils and can seriously degrade unit performance.

The initial step in any start-up operation should be a final visual inspection. All equipment, duct-work, and piping should be inspected to verify that all systems are complete and properly installed and mounted and that no construction debris or foreign articles such as paper or drink cans are left in the units.



Fan coils are not intended for temporary heat/cool or ventilation. Units are not designed or equipped to operate in dusty construction environments. Operation of the units in conditions outlined above could result in damage.

Each unit should be checked for loose wires, free blower wheel operation, and loose or missing access panels or doors. Except as required during start-up and balancing operations, no fan coil units should be operated without all the proper duct-work attached, supply and return grills in place, and all access doors and pan-

els in place and secure. A clean filter of the proper size and type must also be installed. Failure to do so could result in damage to the equipment or building and furnishings, and/or void all manufacturers' warranties.

COOLING/HEATING SYSTEM

Prior to the water system start-up and balancing, the chilled/hot water systems should be flushed to clean out dirt and debris, which may have collected in the piping during construction. During this procedure, all unit service valves must be in the closed position. This prevents foreign matter from entering the unit and clogging the valves and metering devices. Strainers should be installed in the piping mains to prevent this material from entering the units during normal operation.

During system filling, air venting from the unit is accomplished by the use of the standard manual, or optional automatic, air vent fitting installed on the coil. In the case of the manual air vent fitting, the screw should be turned counterclockwise no more than 1-½ turns to operate the air vent. Automatic air vents may be unscrewed one turn counterclockwise to speed initial venting but should be screwed in for automatic venting after start-up operations.



The air vent provided on the unit is not intended to replace the main system air vents and may not release air trapped in other parts of the system. Inspect the entire system for potential air traps and vent those areas independently as required. In addition, some systems may require repeated venting over a period of time to properly eliminate air from the system.



Do not exceed 300 PSIG operating pressure.

AIR SYSTEM BALANCING

All ductwork must be complete and connected, and all grilles, filters, and access doors and panels must be properly installed to establish actual system operating conditions BEFORE beginning air balancing operations.

Each individual unit and associated ductwork is a unique system with its own operating characteristics. For this reason, air balancing is normally done by balance specialists who are familiar with all procedures required to properly establish air distribution and fan system operating conditions. These procedures should not be attempted by unqualified personnel. Units without ductwork do not require air balancing other than selecting the desired fan speed.

After the proper system operation is established, the actual unit air delivery and the actual fan motor amperage draw for each unit should be recorded in a convenient place for future reference such as the inspection, installation, and start-up check sheet (see *SECTION 4 - INSPECTION, INSTALLATION & START-UP CHECKLIST*). Contact the Sales Representative or the factory for additional copies of this sheet.

WATER SYSTEM BALANCING

A complete knowledge of the hydronic system, its components, and controls is essential to proper water system balancing and this procedure should not be attempted by unqualified personnel. The system must be complete and all components must be in operating condition BEFORE beginning water system balancing operations.

Each hydronic system has different operating characteristics depending on the devices and controls in the system. The actual balancing technique may vary from one system to another.

After the proper system operation is established, the appropriate system operating conditions such as various water temperatures and flow rates should be recorded in a convenient place for future reference such as the inspection, installation, and start-up check sheet (see *SECTION 4 - INSPECTION, INSTALLATION & START-UP CHECKLIST*). Contact the Sales Representative or the factory for additional copies of this sheet.

Before and during water system balancing, conditions may exist which can result in noticeable water noise or undesired valve operation due to incorrect system pressures. After the entire system is balanced, these conditions will not exist on properly designed systems.

CONTROLS OPERATION

Before proper control operation can be verified all other systems must be in proper operation. The correct water and air temperatures must be present for the control function being tested. Some controls and features are designed not to operate under certain conditions.

A wide range of controls and electrical options and accessories may be used with the equipment covered in this manual. Consult the approved unit submittals, order acknowledgement, and other manuals for detailed information regarding each individual unit and its controls. Since controls and features may vary from one unit to another, care should be taken to identify the controls to be used on each unit and their proper control sequence. Information provided by component manufacturers regarding installation, operation, and maintenance of their individual controls is available upon request.



Fan coil units, which allow water flow through the coils while the fan is in the OFF position, can create condensation on the exterior of the cabinet.

FAN COIL EC MOTOR CONTROL

G3 PWM Board

The Enviro-Tec “Generation 3 PWM” (G3 PWM) board provides a pulse-width modulated (PWM) signal to the EC motor to control fan speed. The board is factory programmed to control the motor in either Three Speed (adjustable) mode or Proportional Control using a remote 2 – 10 V DC input signal. In Proportional Control mode, a 2 – 10 V DC signal will control EC motor speed between factory set minimum (Min) and maximum (Max) values. For either control mode, fan on/off control is enabled via the “G” signal.

Tools Needed

- Digital multimeter capable of measuring 30 volts AC/DC and duty cycle
- Insulated 1/8” flat bladed screwdriver
- Mini Hook Test Clips for multimeter (optional)

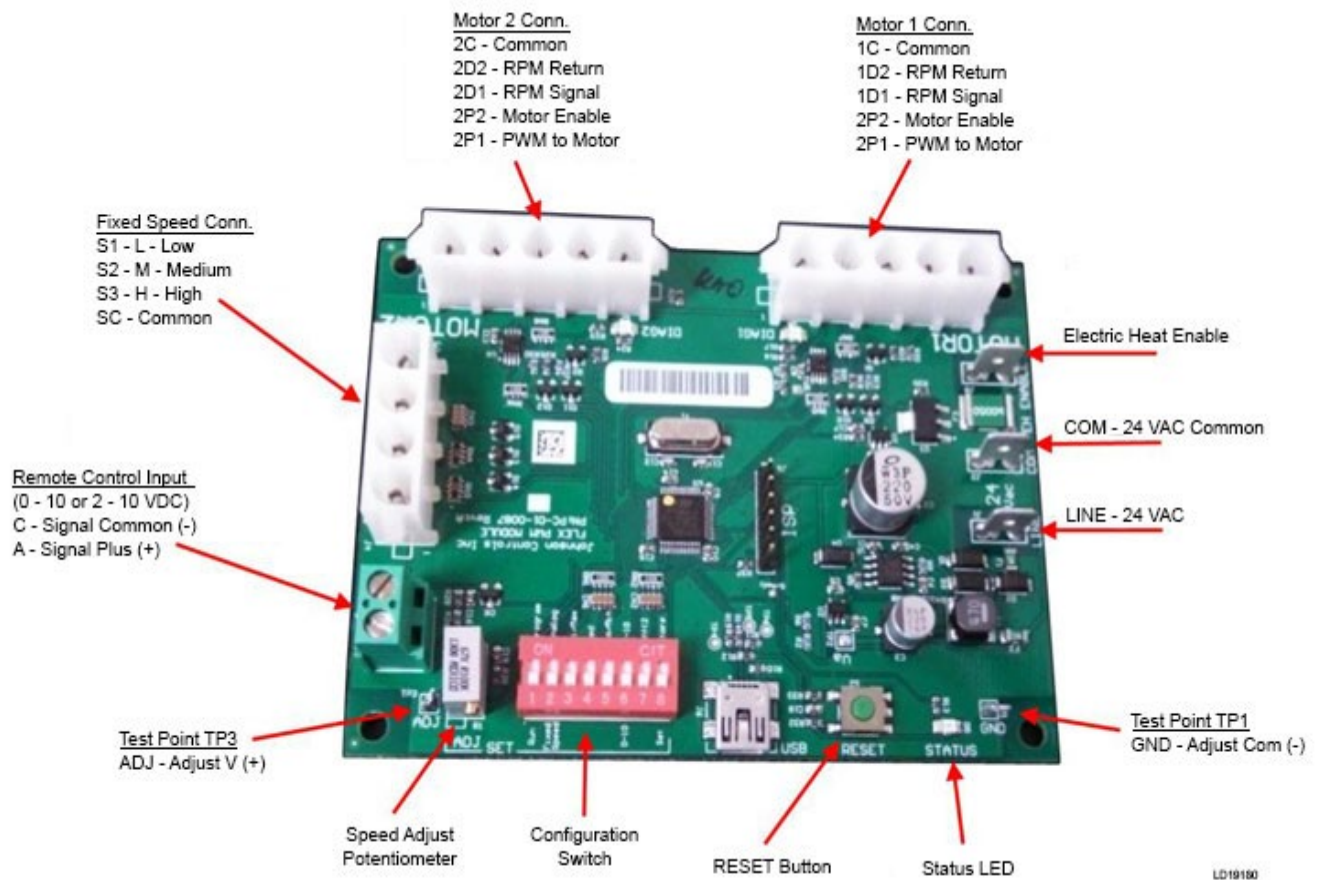

FIGURE 12 - G3 PWM BOARD

PWM Board Status LED

The G3 PWM Status LED (refer to *Figure 12 on page 25*) indicates the status of the G3 PWM board. See *Table 1 on page 25*.

TABLE 1 - G3 STATUS LED DEFINITION

FLASH	MODE	INDICATES
Yes	Run	Normal
Yes	Program	Timed out
Always On	Run	Erro
Always On	Program	Program Mode
Always Off	Any	Fault

G3 PWM Status Descriptions

Normal - (Run mode) - If configuration switch 1 is in Run Mode (OFF) the LED will flash to indicate Normal status.

Timed Out - (Program Mode) - The PWM board has a time out function in Program Mode. If the PWM board has timed out in Program Mode, the LED will flash. Time Out may be cleared by pushing the Reset Button.

Error - (Run Mode) - If configuration switch 1 is in Run mode (OFF) and the LED is always ON, there is a system error. Verify all connections and proper input voltage at Line and Com, then push the Reset Button. If this fails to return the board to Normal mode, replace the board.

Program Mode - If configuration switch 1 is in Program Mode (ON) the LED will be always ON to indicate that the board is in Program Mode. See Figure 2.

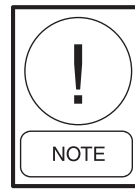

While in Program Mode, the fan motor will not run.

Fault - (Any mode) - If the LED remains OFF, the board either has no power or is faulted. Verify proper input voltage at Line and Com, then push the Reset Button. If this fails to return the board to expected mode, replace the board.

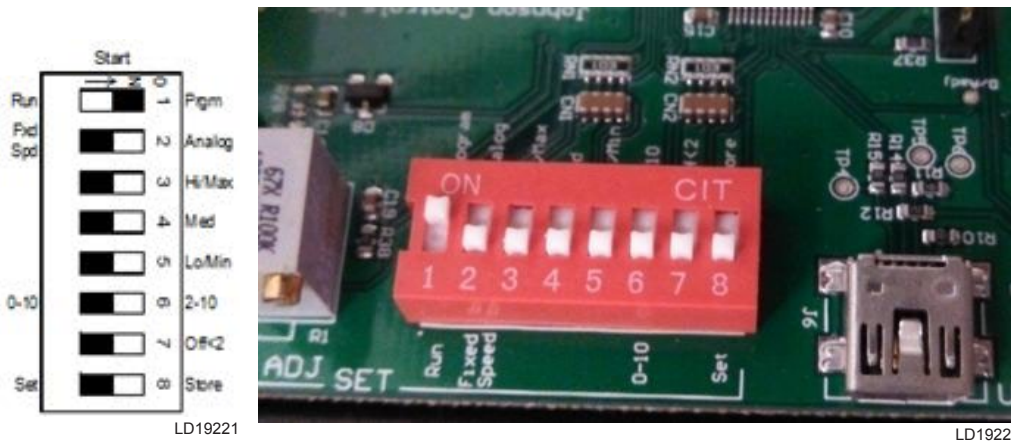

FIGURE 13 - PROGRAM MODE (CONFIGURATION SWITCH 1 ON)



All power must be disconnected prior to installation and servicing this equipment. More than one source of power may be present. Disconnect all power sources to avoid electrocution or shock injuries. Refer to lock out tag out procedures.

1. Make sure there are no obstructions in the discharge ductwork and/or at the plenum opening.
2. Locate the G3 PWM board in the control enclosure. Refer to Figure 1 for location of test points TP3 and TP1, the Configuration Switch, Speed Adjust Potentiometer, and Reset Button.
3. Place Configuration Switch into Program Mode. Use an insulated screwdriver to flip configuration switch #1 (closest to speed adjust potentiometer) to the ON position. See *Figure 13 on page 26*.

4. Press Reset button. Connect a voltmeter to test points TP1 (-) and TP3 (+). Refer to Figure 1. Set voltmeter to DC volts.

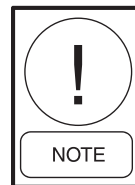

The PWM board must be in Program Mode to read voltage across TP1 and TP3.

5. Apply power to the unit. Verify that the status LED is Always On, indicating that the PWM board is in Program Mode. If the status LED blinks while in Program Mode, the board has timed out. In this case, push the reset button and verify the status LED returns to Always On.

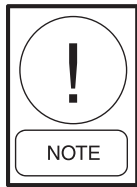

The PWM board times out in Program Mode after approximately 5-6 minutes and will need to be reset by pushing the reset button. If more time is needed to verify correct airflow, perform the STORE operation (through switch 8) after adjustment to save the adjusted fan speed.

6. Determine desired fan operating points. Refer to the Fan Calibration Curve label supplied on the side of the equipment. There are two different styles of Fan Calibration Curve, depending on EC motor type.

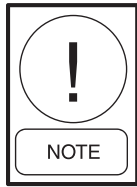

The Fan Calibration Curve provided with the unit represents response for a unit with typical configuration. Actual airflow may vary slightly depending on actual system configuration.

- a. Constant RPM EC Motor. Refer to *Figure 14* on page 27 for sample label. Five curves are shown, showing factory default airflow for Minimum, Low, Medium, High, and Maximum speeds. A table is provided which shows the expected voltage across test points TP1 and TP3 for each speed, depending on whether the unit is set up for three speed or 2 – 10 VDC motor control.
- b. Constant Airflow or Constant Torque EC Motor. Refer to *Figure 15* on page 27 for sample label. Several curves are shown on the label, one for each size unit. Refer to the 0 to 2.5 volt scale on the label and use the voltmeter to read the voltage across TP1 and TP3 to determine desired airflow setting.

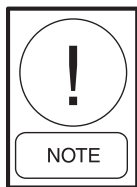

Changing the factory setting for minimum and maximum CFMs will invalidate the range for the Fan Calibration Curve as it will narrow the scale of the input signal.

7. Follow instructions for adjusting EC motor speed using the G3 PWM board. Separate instructions are provided for Three Speed (adjustable) and 2 – 10 VDC Proportional motor control modes.

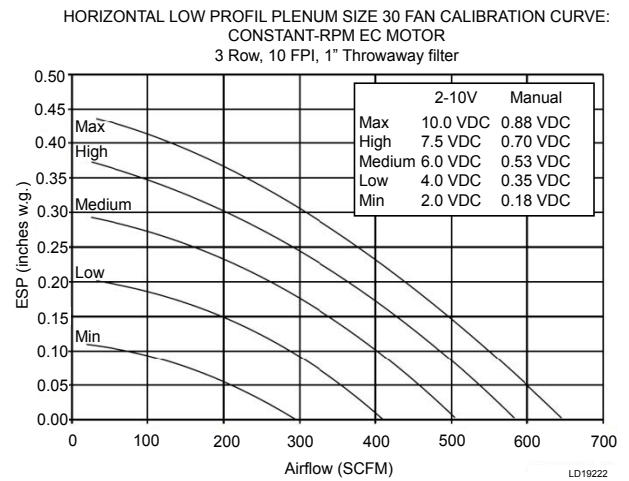

FIGURE 14 - CONSTANT RPM AND CONSTANT TORQUE EC MOTORS EXAMPLE FAN CALIBRATION CURVE

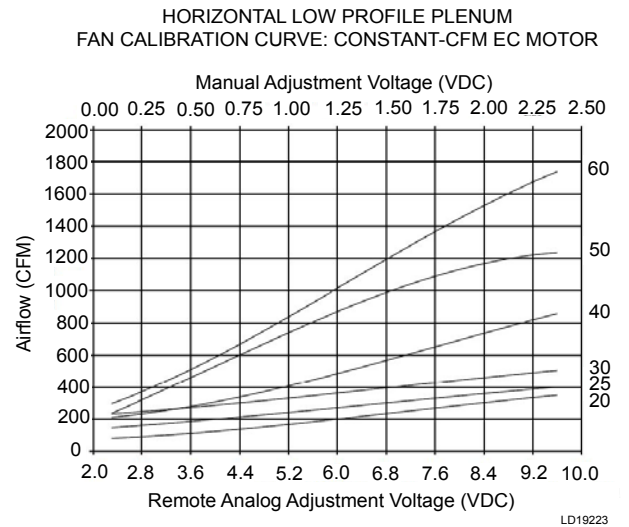

FIGURE 15 - CONSTANT AIRFLOW AND CONSTANT TORQUE EC MOTORS EXAMPLE FAN CALIBRATION CURVE

Adjusting EC Motor Speed

This section contains instructions for using the G3 PWM board to adjust the EC motor speed for balancing purposes. There are two modes of EC motor speed control: Three Speed operation at three fixed (adjustable) speeds, or Proportional Control with remote 2 – 10 VDC signal.



For units with electric heat, fan speed must not be adjusted below 70 CFM/kW.

Refer to *Figure 12 on page 25* for location of Configuration Switch, speed Adjust Potentiometer, and Reset Button. These will be used to program the EC operating mode and motor speed settings.

Three Speed (Adjustable) Motor Control

High, Medium, and/or Low speed adjustment for three speed operation.

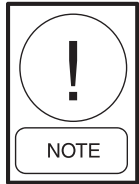

Thermostat must be set for three speed operation.

1. **High Speed Setting Adjust:** Set Configuration Switch to HIGH SPEED adjust (see *Figure 16 on page 28*). Switches to ON-OFF-ON-OFF-OFF-OFF-OFF-OFF-OFF.

- Set switch 1 to ON (Program).
- Set switch 2 to OFF (Fixed Speed).
- Set switch 3 to ON (Hi/Max).
- Set switches 4 through 8 to OFF.
- Press RESET button.

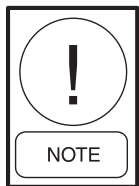

RESET button only needs to be pressed once per programming session unless board times out. Refer to Status LED.

- Refer to voltmeter connected to TP1 and TP3. Using an insulated 1/8" flat bladed screwdriver, adjust speed potentiometer to desired high speed airflow per Fan Calibration Curve on unit.
- **STORE:** Set switch 8 to Store (ON), wait one second, then to Set (OFF), to save the value.

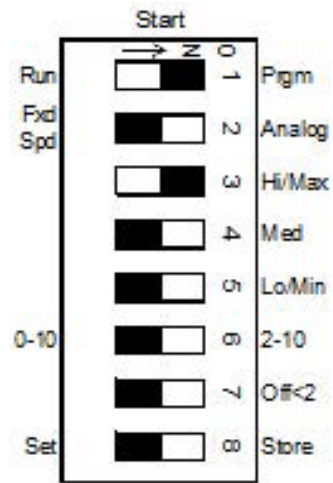

FIGURE 16 - HIGH SPEED ADJUST

2. **Medium speed Adjust:** Set Configuration Switch to MEDIUM SPEED adjust (see *Figure 17 on page 28*). Switches to ON-OFF-OFF-ON-OFF-OFF-OFF-OFF-OFF.

- Set switch 1 to ON (Program).
- Set switches 2 -3 to OFF.
- Set switch 4 to ON (Med).
- Set switches 5 through 8 to OFF.
- Refer to voltmeter connected to TP1 and TP3. Using an insulated 1/8" flat bladed screwdriver, adjust speed potentiometer to desired high speed airflow per Fan Calibration Curve on unit.
- **STORE:** Set switch 8 to Store (ON), wait one second, then to Set (OFF), to save the value.

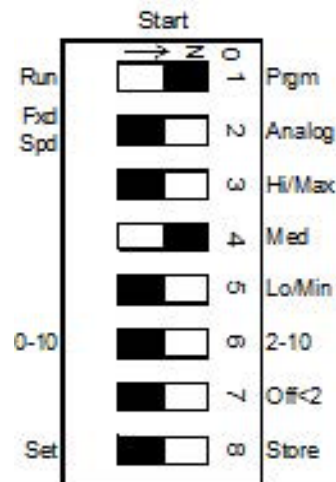

FIGURE 17 - MEDIUM SPEED ADJUST

3. **Low Speed Adjust:** Set Configuration Switch to LOW SPEED adjust (see *Figure 18 on page 29*). Switches to ON-OFF-OFF-OFF-ON-OFF-OFF-OFF

- Set switch 1 to ON (Program).
- Set switches 2 -4 to OFF.
- Set switch 5 to ON (Lo/Min).
- Set switches 6 through 8 to OFF.
- Refer to voltmeter connected to TP1 and TP3. Using an insulated 1/8" flat bladed screwdriver, adjust speed potentiometer to desired high speed airflow per Fan Calibration Curve on unit.
- **STORE:** Set switch 8 to Store (ON), wait one second, then to Set (OFF), to save the value.

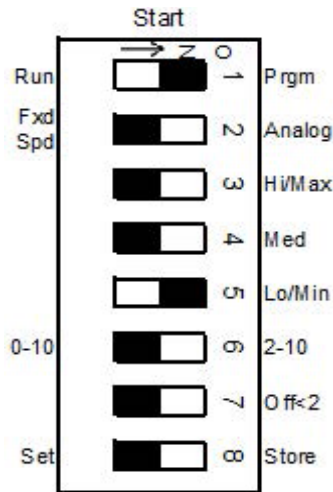

FIGURE 18 - LOW SPEED ADJUST

4. **Resume Normal Three Speed Operation:** Set all switches to OFF to resume normal three speed operation. Refer to *Figure 19 on page 29*.

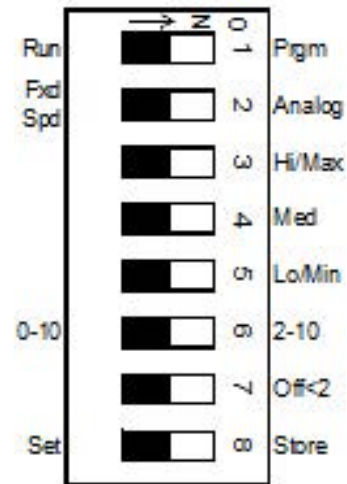
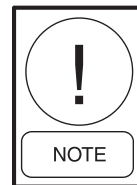

FIGURE 19 - NORMAL THREE SPEED OPERATION

2 – 10 VDC PROPORTIONAL MOTOR CONTROL

Speed range adjustment for Proportional Control operation. Minimum (Min) and maximum (Max) speeds are programmed at the factory for optimum operation. Changing factory Min or Max speed defaults will change the motor effective speed range and invalidate the voltage settings shown on the Fan Calibration Curve. However, the speed range may still be adjusted as long as the Min speed remains greater than 70 CFM/kW for units with electric heat.



Thermostat must be set for either analog or single (high) speed operation.

1. **Connections:** Connect or verify connection of remote analog signal and common wires to 2-10 VDC Remote Control Input terminals (refer to *Figure 12 on page 25*).
2. **Set Mode to 2 – 10 VDC Proportional Control:** Set configuration switches to 2 – 10 ANALOG programming mode (see *Figure 20 on page 30*). Switches to ON-ON-OFF-OFF-OFF-ON-OFF-OFF.
 - Set switch 1 to ON (Program).
 - Set switch 2 to ON (Analog).
 - Set switches 3 – 5 to OFF.
 - Set switch 6 to ON (2-10 V).

- Set switches 7 and 8 to OFF.
- Press RESET button.



RESET button only needs to be pressed once per programming session unless board times out. Refer to Status LED.

- **STORE:** Set switch 8 to Store (ON), wait one second, then to Set (OFF), to save the value.

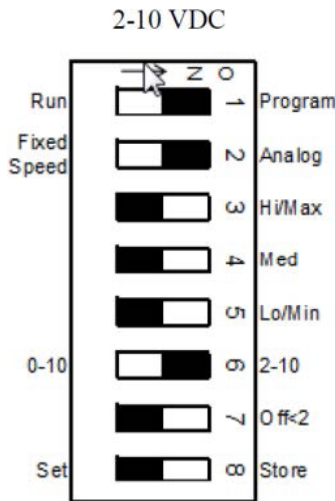
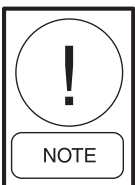

FIGURE 20 - MODE TO 2-10 VDC PROPORTIONAL CONTROL



If adjusting Min/Max CFM values, continue to step 3. Otherwise, skip to step 5.

3. Max Speed Adjust: Set configuration switches to HI/MAX SPEED balancing mode (see *Figure 21 on page 30*). Switches to ON-ON-ON-OFF-OFF-ON-OFF-OFF.

- Set switch 1 to ON (Program).
- Set switch 2 to ON (Analog).
- Set switch 3 to ON (Hi/Max).
- Set switches 4 and 5 to OFF.
- Set switch 6 to ON (2-10 V).
- Set switches 7 and 8 to OFF.
- Refer to voltmeter connected to TP1 and TP3. Using an insulated 1/8" flat bladed screwdriver, adjust speed potentiometer to desired Max speed airflow.
- **STORE:** Set switch 8 to Store (ON), wait one second, then to Set (OFF), to save the value.

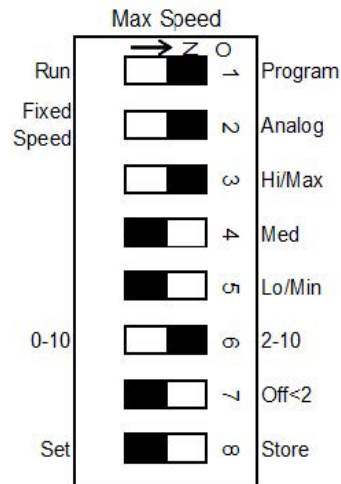

FIGURE 21 - MAX SPEED ADJUST

4. **Min Speed Adjust:** Set configuration switches to LO/MIN SPEED balancing mode (see *Figure 22 on page 31*). Switches to ON-ON-OFF-OFF-ON-ON-OFF-OFF.

- Set switch 1 to ON (Program).
- Set switch 2 to ON (Analog).
- Set switches 3 and 4 to OFF.
- Set switch 5 to ON (Lo/min).
- Set switch 6 to ON (2-10 V).
- Set switches 7 and 8 to OFF.
- Refer to voltmeter connected to TP1 and TP3. Using an insulated 1/8" flat bladed screwdriver, adjust speed potentiometer to desired Min speed airflow.
- **STORE:** Set switch 8 to Store (ON), wait one second, then to Set (OFF), to save the value.

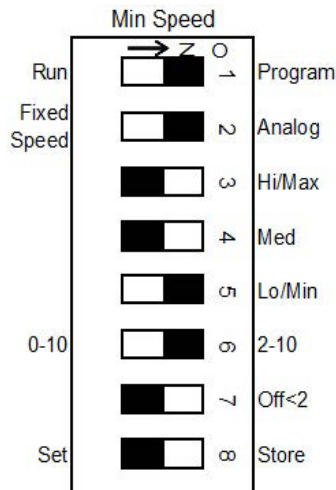

FIGURE 22 - MIN SPEED ADJUST

5. **Resume Normal 2 – 10 V DC Proportional Control:** Set configuration switches to OFF-ON-OFF-OFF-OFF-OFF-ON-OFF-OFF for normal proportional speed control, as shown in *Figure 23 on page 31*.

- Set switch 2 to ON (Analog).
- Set switch 6 to ON (2 – 10).
- Set all other switches to OFF.

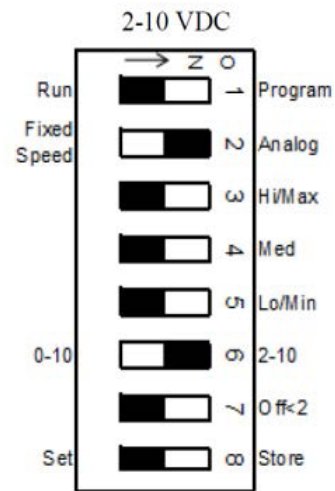

FIGURE 23 - NORMAL 2 – 10 VDC SPEED CONTROL

EC MOTOR TROUBLESHOOTING GUIDELINES

Ensure motors and blowers are clean as part of normal maintenance. No further maintenance is required for these motors.



Follow standard lock out tag out (LOTO) procedures when performing service on motor or blower.

TABLE 2 - EC MOTOR TROUBLESHOOTING GUIDELINES

PROBLEM	POSSIBLE CAUSE	CORRECTIVE ACTION
Motor fails to start	No or loose enable jumper (constant RPM motor only)	Verify enable jumper connected properly to motor driver. Refer to <i>Constant RPM EC Motor Driver Enable Jumper</i> on page 37.
	No power to motor. Possible blown fuse or open circuit breaker	Verify line voltage at motor driver. Replace fuse or reset circuit breaker.
	PWM configuration switch in program mode	Configuration switch 1 must be in Run mode (<i>Figure 13</i> on page 26). Refer also to <i>PWM Board Status LED</i> on page 25.
	PWM board faulted	Refer to <i>PWM Board Status LED</i> on page 25. Verify voltage input, wiring and connections. Push reset button. Replace PWM board if fault returns.
	No control signal (constant RPM)	Constant RPM EC motors will not rotate if they lose PWM signal while enabled. Verify PWM signal at motor connector by connecting a multimeter set for "duty cycle" between pins 1P1 and 1C (or between pins 2P1 and 2C). The duty cycle represents the on-time percentage signal sent to the motor (this number will vary between the minimum and maximum duty cycle set by the factory). See <i>Figure 12</i> on page 25 for PWM board connections. Refer also to <i>PWM Board Status LED</i> on page 25 to verify board is in normal operating mode.
	Improper wiring connections	Verify wiring. If Fan Coil Relay board present, verify all jumpers installed. Refer to Fan Coil Relay Board Troubleshooting Guide.
	EC motor wiring harness improperly seated	Unplug harness and re-install, making sure plugs are fully seated.
	EC motor wiring harness(es) open or intermittent	Replace harness(es). See section on <i>Checking EC Wire Harnesses</i> on page 35.
	Blower jammed	Clear blockage. Verify blower rotates freely with motor disconnected.
	No 24 VAC power	Refer to Fan Coil Relay Board Troubleshooting Guide.
	Float switch tripped	Verify float switch (if present) is made.
	Motor seized	Verify motor rotates freely by hand with blower disconnected. If not, replace motor.
Damaged motor cable	Cable is integral to motor, replace motor.	

TABLE 2 - EC MOTOR TROUBLESHOOTING GUIDELINES (CONT'D)

PROBLEM	POSSIBLE CAUSE	CORRECTIVE ACTION
Motor surges	Fan speed adjustment outside operating range	Refer to Fan Calibration curve on unit. Adjust speed on PWM Controller to value that will allow motor to start. See instructions for <i>Adjusting EC Motor Speed on page 27</i> .
	Blower Screw loose	Tighten Screw onto motor shaft.
	ESP (external static pressure) too high	Verify dampers, if present, are not closed. Verify there are no obstructions in the discharge ductwork and/or at the plenum opening. Verify filter is not dirty and does not obstruct airflow.
Poor performance	Lack of required external static pressure	Add required external static pressure.
	Speed adjustment outside fan operating range	Refer to Fan Calibration curve on unit. Adjust speed on PWM Controller to value that will allow motor to start. See instructions for <i>Adjusting EC Motor Speed on page 27</i> .
	Erratic speed command (in Proportional Control mode)	Verify 2-10V analog signal at Remote Control Input terminals.
	Damaged or blocked blower	Verify blower rotates freely. Clear blockage.
Motor starts but stops	Voltage or ground loss at motor driver	Verify proper voltage and ground at motor driver power terminals. Refer to Motor Driver Connections for the EC motor.
	Motor overloaded - blower binding	Clear blockage. Verify blower rotates freely with motor disconnected.
	Motor overloaded	Use amp meter to verify motor amps. Verify motor rotates freely with power disconnected. If not, replace motor.
	Open ductwork for concealed units	Verify ducts sealed properly.
	Motor overheated due to lack of airflow	Verify dampers, if present, are not closed. Verify there are no obstructions in the discharge ductwork and/or at the plenum opening. Verify filter is not dirty and does not obstruct airflow.
	PWM board error or faulted	Refer to <i>PWM Board Status LED on page 25</i> . Verify all connections. Push reset button. Replace board if fault returns.
	Motor driver failure	Replace motor (Constant airflow or constant torque motors.) Replace driver (Constant RPM motor.)
	Damaged motor cable	Cable is integral to motor, replace motor.

TABLE 2 - EC MOTOR TROUBLESHOOTING GUIDELINES (CONT'D)

PROBLEM	POSSIBLE CAUSE	CORRECTIVE ACTION
Motor speed cannot be adjusted	PWM board error or faulted	Refer to <i>PWM Board Status LED</i> on page 25. Verify all connections. Push reset button. Replace board if fault returns.
	Improper wiring connections	Verify wiring. If Fan Coil Relay board present, verify all jumpers installed.
	EC wiring harness damaged or improperly seated	Unplug harness and re-install, making sure plugs are fully seated. See section on <i>Checking EC Wire Harnesses</i> on page 35. Replace harness if damaged.
	No control signal (constant airflow and constant torque)	Constant airflow and constant torque EC motors will run at idle speed if they lose PWM signal while enabled. Verify PWM signal at motor connector by connecting a multimeter set for "duty cycle" between pins 1P1 and 1C (or between pins 2P1 and 2C). The duty cycle represents the on-time percentage signal sent to the motor (this number will vary between the minimum and maximum duty cycle set by the factory). See <i>Figure 12</i> on page 25 for PWM board connections. Refer also to <i>PWM Board Status LED</i> on page 25 to verify board is in normal operating mode.
	ESP (external static pressure) too high	Verify dampers, if present, are not closed. Verify there are no obstructions in the discharge ductwork and/or at the plenum opening. Verify filter is not dirty and does not obstruct airflow.
	Motor driver failure	Replace motor (constant airflow or constant torque motors) Replace driver (constant RPM motors)
Motor runs in reverse, does not respond to speed adjustment	Motor driver failure	Replace motor (constant airflow or constant torque motors) Replace driver (constant RPM motors)
Excessive motor noise	Motor mounting bolts loose	Tighten motor mounting bolts.
	Motor bearing	Replace motor.
	Motor overloaded	Use amp meter to verify motor amps. Verify motor rotates freely with power disconnected. If not, replace motor. Verify static pressure within limits shown on Fan Calibration Curve on unit.
	Fan wheel rubbing on fan housing	Align wheel in housing.
	Loose fan wheel	Align and tighten.
Motor runs in G3 PWM Program mode but not in Run mode	Loose pin in Fixed Speed Conn. harness	Verify that the pins in the Fixed Speed Conn. harness (see location in <i>Figure 12</i> on page 25) are inserted fully.

CHECKING EC WIRE HARNESES

Use ohmmeter to verify that motor ground wire has continuity from motor case to ground.

To check signal wire harnesses:

- Remove power from the unit. Unplug signal harness at EC driver and from motor connector at PWM board.
- Use ohmmeter to check continuity for each conductor, then reconnect harnesses to driver and to PWM board.

To check power wire harness:

- Refer to wiring diagram.
- Remove power from the unit. Unplug power harness at EC driver.
- Verify green wire has continuity to ground.
- Unplug power wires from connections in electrical enclosure. Verify continuity of wires to motor driver, then reconnect to same terminals.

Before reconnecting power to unit, verify all harnesses are connected per diagram.



Use light force when inserting meter probe into plug. Excess force will damage contacts.

EC MOTOR AND DRIVER

There are two types of EC motor:

- Constant RPM EC motor, both single and double shaft.
- Constant Airflow or Constant Torque EC motor, both single and double shaft.

Constant Airflow/Constant Torque EC Motors



LD19307

FIGURE 24 - CONSTANT CFM/CONSTANT TORQUE EC MOTORS (1/3 HP SHOWN)



LD19309

FIGURE 25 - CONSTANT CFM/CONSTANT TORQUE EC MOTOR DRIVER

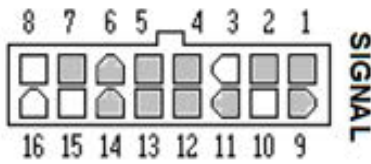

LD19310

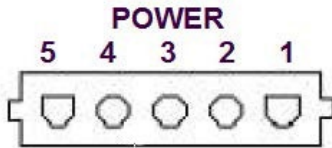

LD19311

TABLE 3 - SIGNAL CONNECTOR

PIN	DESCRIPTION
1	C1 (n/u - com)
2	W/W1 (n/u)
3	C2 (PWM COM)
4	DELAY (n/u)
5	COOL (n/u)
6	Y1 (n/u)
7	ADJUST (n/u)
8	OUT - (PWM FB)
9	O (n/u)
10	PWM
11	HEAT (n/u)
12	R (n/u)
13	EM/W2 (n/u)
14	Y/Y2 (n/u)
15	G (Fan Enable)
16	OUT + (PWM FB)

NOTE:
Connections marked (n/u) are not used.

TABLE 4 - POWER CONNECTOR

PIN	DESCRIPTION
1	Jumper pin 1 to pin 2 for 120 VAC Line Input only
2	
3	Chassis Ground
4	AC Line (Line 1)
5	AC Line (Line 2, Neutral)

Constant RPM EC Motors



LD19312

FIGURE 26 - CONSTANT RPM EC MOTOR (1/4 HP SHOWN)



LD19313

FIGURE 27 - CONSTANT RPM EC MOTOR DRIVER

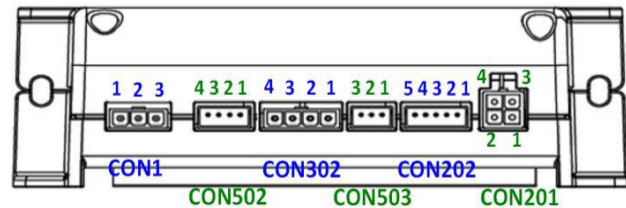

LD19314

TABLE 5 - CON1, POWER INPUT

PIN	DESCRIPTION
1	Ground
2	Neutral (or Line 2)
3	Line 1

TABLE 6 - CON502 (IF PRESENT), PROGRAMMING CONNECTOR

PIN	DESCRIPTION
1	+15V
2	Ground
3	TX-
4	TX+

TABLE 7 - CON302, PWM SIGNAL INPUT

PIN	DESCRIPTION
4	Speed Control Input (H)
3	Speed Control Input (L)
2	Speed Control Input (H)
1	Speed Control Input (L)

TABLE 8 - CON503 (IF PRESENT), MOTOR ENABLE INPUT

PIN	DESCRIPTION
1	No Connection
2	Signal Input
3	Ground

TABLE 9 - CON202, FEEDBACK FROM EC MOTOR HALL SENSOR

PIN	DESCRIPTION
1	+5V
2	Ground
3	Hall "W"
4	Hall "V"
5	Hall "U"

TABLE 10 - CON201, OUTPUT POWER TO MOTOR

PIN	DESCRIPTION
1	W1
2	NC
3	V1
4	U1

Constant RPM EC Motor Driver Enable Jumper

The ETI Constant RPM EC motor driver has a Motor Enable Input. These drivers require a jumper across the Enable Connector to allow the unit to operate. See Figure 10 for jumper location across pins 2 and 3 of the Enable Connector.

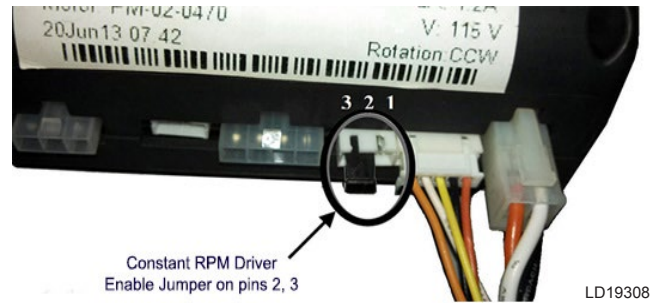

FIGURE 28 - CONSTANT RPM EC DRIVER EC MOTOR ENABLE CONNECTOR

2

ECM 3-SPEED CONSTANT TORQUE MOTOR TROUBLESHOOTING GUIDE

TABLE 11 - ECM CONSTANT TORQUE MOTOR SPECIFIC TROUBLESHOOTING GUIDELINES

PROBLEM	POSSIBLE CAUSE	CORRECTIVE ACTION
Motor Fails to Start	HVAC system not calling for operation	Verify the thermostat, if supplied, is operating properly and/or the applicable thermostat is connected to your unit.
	Signal voltage at FRCB out of range	Verify FCRB* jumper is connected from '24VAC' – 'R' terminal to 'MTR PWR' terminal. Measure signal voltage from FCRB '24VAC' – 'COM' terminal to each of 'TO FAN MTR' 'HIGH', 'MED', and 'LOW' terminals. Verify voltages range from 12 to 33VAC. If any voltage is out of range, replace the FCRB.
	Motor voltage not present	Verify the motor line voltage (black harness wire) is connected to the applicable 'LINE VOLTAGE IN' terminal on the FCRB. Measure voltage from the applicable 'LINE VOLTAGE IN' terminal to the 'P1' terminal on the FCRB. Verify the applicable voltage is present. If no voltage is present, verify voltage at the line.
	Wiring harness improperly connected	With power removed from the unit , verify that connectors at motor, panel, and FCRB seat correctly. If not, reconnect them.
	Loose wires in wiring harness	With power removed from the unit , verify that none of the wiring harnesses have loose wires.**
	Wiring harness is defective or damaged	With power removed from the unit and the wiring harnesses disconnected, verify continuity of harness from FCRB and from equipment ground to motor connector. Replace wiring harness if suspect. Refer to <i>Procedure for Checking ECM Constant Torque Wiring Harnesses on page 39</i>
	Mechanical failure of motor	Remove power from the unit. Replace the motor.
Motor Surges	ESP (external static pressure) too high	Verify there are no discharge obstructions and the coil fins are clean. Verify plenum is unobstructed. Verify the filter is clean and does not obstruct flow of plenum air. Verify that the High Static Option plug (red) is connected if static is high.
Excessive Motor Noise	Motor mount loose	With power removed from the unit , tighten motor mounting bolts.
	Fan wheel loose or rubbing on fan housing	With power removed from unit , loosen fan wheel, align wheel in housing, then retighten.
Poor Performance	Lack of required ESP	Adjust system to provide required static pressure. (See fan curve.)
	Wrong motor program	Contact factory.
Motor runs in reverse or not responding to speed adjustment	Motor failure	Remove power from the unit. Replace motor.

* - Fan Coil Relay Board

** - Verify wiring harnesses have no loose wires by gently pulling on each wire.

Procedure for Checking ECM Constant Torque Wiring Harnesses

1. Remove power from the unit. Lock and tag out power source.
2. Verify that equipment is properly grounded.
3. Unplug ECM Motor Power wiring harness, and use ohmmeter to verify continuity (see *Table 12 on page 39* for details.)
4. Verify continuity from green wire (motor ground) to equipment ground.
5. Unplug ECM Motor Signal wiring harness, and use ohmmeter to verify continuity (see *Tables 13 and 14 on page 40* for details.)
6. Replace all connections. Ensure good connections are made.



Only very light force is required when inserting meter probe into plug. Excess force will damage contacts.

ECM Constant Torque Motor Connections

The ECM Constant Torque motor connector is located on the side of the motor. It has two rows of terminals, as shown in *Figure 29 on page 39*. The Power (4-pin) connector plugs into the top row. The Signal (5-pin) connector plugs into the bottom row.

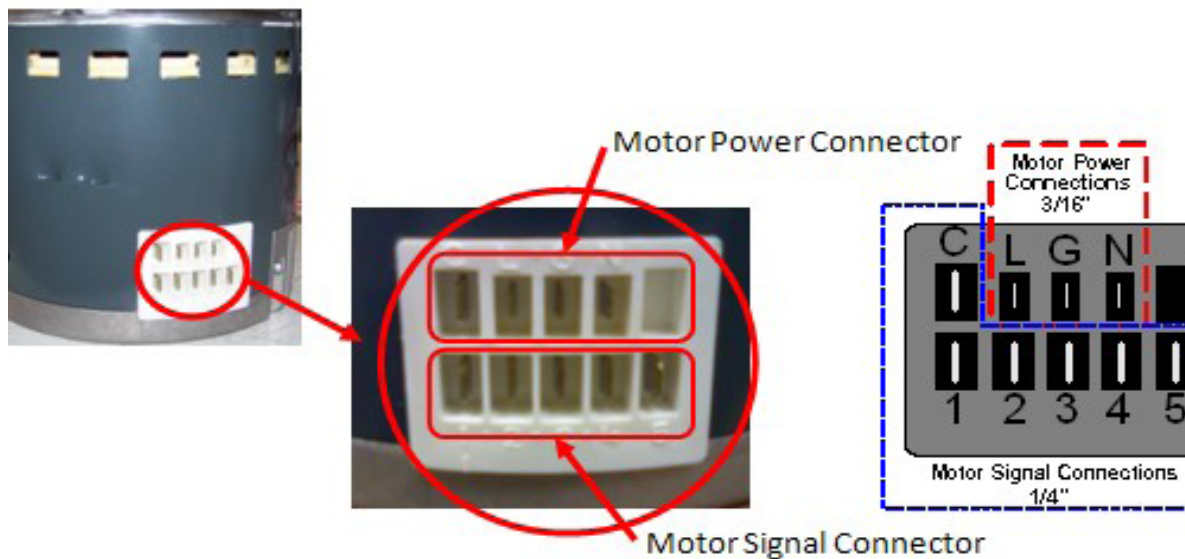

FIGURE 29 - MOTOR POWER AND SIGNAL CONNECTORS

TABLE 12 - THE ECM CONSTANT TORQUE MOTOR POWER WIRING HARNESS

<i>Motor Power Connector</i>	WIRE COLOR	FUNCTION	MOTOR CONNECTION	FCRB CONNECTION
	Purple	Signal Common	C	24 VAC - COM
	Black	Line Voltage	L	Line Voltage In - see equipment
	Green	Ground	G	N/A - Ground
	White	Neutral	N	P1 - L2/Neut

TABLE 13 - THE STANDARD ECM CONSTANT TORQUE MOTOR SIGNAL WIRING HARNESS (WHITE PLUG)

	WIRE COLOR	FUNCTION	MOTOR CONNECTION	FCRB CONNECTION
1	Yellow	Standard Option Low Speed	1	TO FAN MOTOR - LOW
2	Red	Standard Option Medium Speed	3	TO FAN MOTOR - MED
3	Black	Standard Option High Speed	4	TO FAN MOTOR - HIGH

TABLE 14 - THE HIGH STATIC ECM CONSTANT TORQUE MOTOR SIGNAL WIRING HARNESS (RED PLUG)

	WIRE COLOR	FUNCTION	MOTOR CONNECTION	FCRB CONNECTION
1	Orange	High Static Option Low Speed	2	TO FAN MOTOR - LOW
2	Gray	High Static Option Medium Speed	4	TO FAN MOTOR - MED
3	Blue	High Static Option High Speed	5	TO FAN MOTOR - HIGH

ECM Constant Torque Motor Specifications**TABLE 15 - ECM CONSTANT TORQUE MOTOR PART NUMBERS**

TYPE	POWER	PART #	VOLTAGE
ECM 3 SPD	1/3 HP	PM-02-0425	277
ECM 3 SPD	1/3 HP	PM-02-0426	115
ECM 3 SPD	1/3 HP	PM-02-0427	208/230

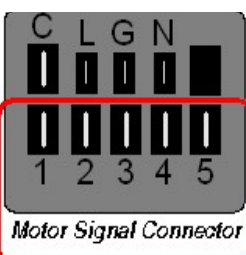
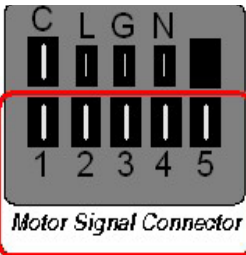
TABLE 16 - MOTOR SIGNAL TAP SPECIFICATIONS

Min 'On' voltage greater than	12VAC or 15VDC
Maximum voltage	33VAC or 23VDC
Min 'Off' voltage less than	5.5VAC or 8VDC
Minimum frequency	47 Hz
Nominal frequency	50 or 60 Hz
Maximum frequency	126 Hz
Min current draw	2 m
Nominal current draw	6 mA
Maximum current draw	12 mA

TABLE 17 - GENERAL ECM CONSTANT TORQUE MOTOR SPECIFICATIONS

HP	MOTOR+CONTROL WEIGHT (LBS)	END TO END LENGTH	MAX RATINGS @ NOM V, 1050 RPM		
			TORQUE (OZ-FT)	WATTS IN (45C)	WATTS IN (55C)
1/3	9.2	5.275"	27	350	350

THIS PAGE INTENTIONALLY LEFT BLANK

FIELD NOTES:

1. FIELD WIRING MUST BE COPPER CONDUCTOR, RATED AT 75°C MINIMUM.
2. ADDITIONAL MOTOR WIRED IN PARALLEL.
3. REMOVE SPEED SELECT JUMPER JP1 IF T*STAT OR 3 SPEED SWITCH PROVIDED. OTHERWISE, TO CHANGE SPEED, REMOVE JUMPER FROM "HIGH" TERMINAL AND CONNECT TO "MED" OR "LOW" TERMINAL.
4. OPTIONAL ITEM SHOWN. SEE ORDER ACKNOWLEDGEMENT FOR OPTIONAL ITEM REQUIREMENTS.
5. FIELD WIRING IS REQUIRED IF VALVE PACKAGE NOT SUPPLIED, OR EXTERNAL TO UNIT.
6. REMOVE JP3 FOR REMOTE CONTROL USING "G".
7. IF FLOAT SWITCH PROVIDED, ATTACH JP2 TO ONE PIN ONLY; OTHERWISE ATTACH TO BOTH PINS.
8. WIRE FIELD SUPPLIED START/STOP CONTACT IN SERIES WITH OPTIONAL FLOAT SWITCH, IF PROVIDED. OTHERWISE, INSTALL JP2.
9. ADDITIONAL HEATER ELEMENT(S) WIRED IN PARALLEL.
10. OPTIONAL TOGGLE DISCONNECT MAY BE PROVIDED IN LIEU OF DOOR INTERLOCKING DISCONNECT.

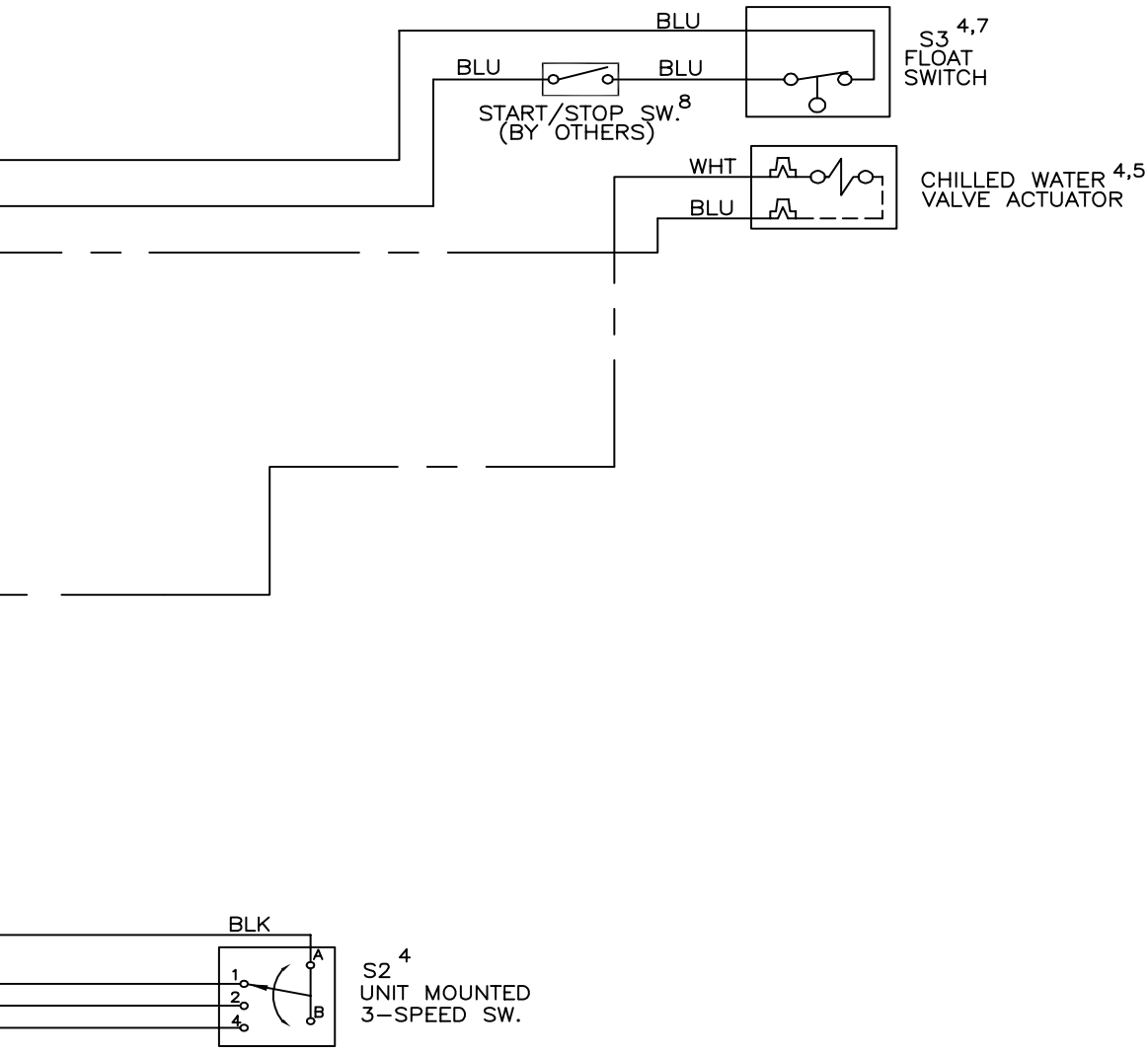

FIGURE 29 - EXAMPLE WIRING DIAGRAM (CONT'D)

LD19179

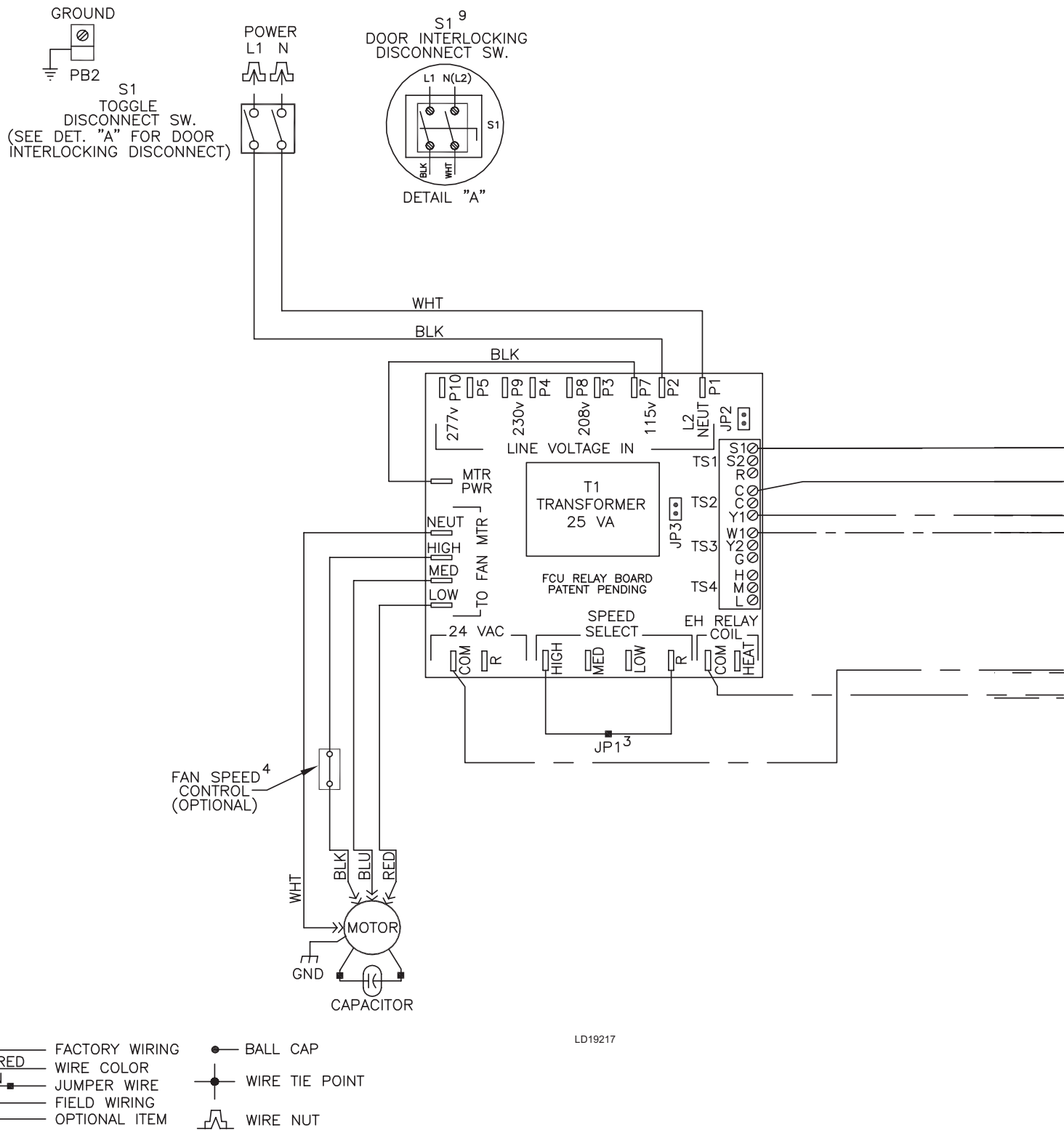
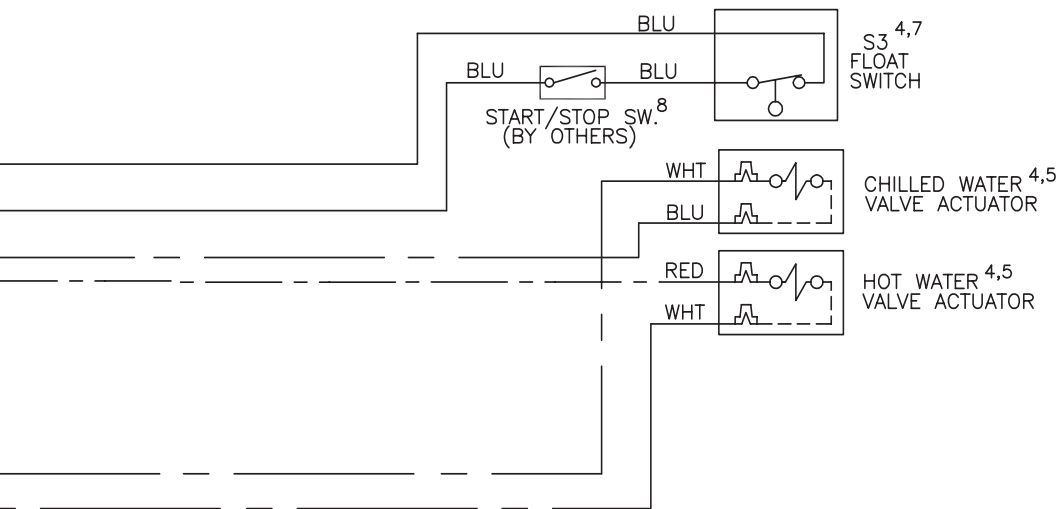

FIGURE 31 - EXAMPLE WIRING DIAGRAM 2

FIELD NOTES:

1. FIELD WIRING MUST BE COPPER CONDUCTOR, RATED AT 75°C MINIMUM.
2. ADDITIONAL MOTOR WIRED IN PARALLEL.
3. REMOVE SPEED SELECT JUMPER JP1 IF T'STAT OR 3 SPEED SWITCH PROVIDED. OTHERWISE, TO CHANGE SPEED, REMOVE JUMPER FROM "HIGH" TERMINAL AND CONNECT TO "MED" OR "LOW" TERMINAL.
4. OPTIONAL ITEM SHOWN. SEE ORDER ACKNOWLEDGEMENT FOR OPTIONAL ITEM REQUIREMENTS.
5. FIELD WIRING IS REQUIRED IF VALVE PACKAGE NOT SUPPLIED, OR EXTERNAL TO UNIT.
6. REMOVE JP3 FOR REMOTE CONTROL USING "G".
7. IF FLOAT SWITCH PROVIDED, ATTACH JP2 TO ONE PIN ONLY; OTHERWISE ATTACH TO BOTH PINS.
8. WIRE FIELD SUPPLIED START/STOP CONTACT IN SERIES WITH OPTIONAL FLOAT SWITCH, IF PROVIDED. OTHERWISE, INSTALL JP2.
9. OPTIONAL DOOR INTERLOCKING DISCONNECT MAY BE PROVIDED IN LIEU OF TOGGLE DISCONNECT.



LD19218

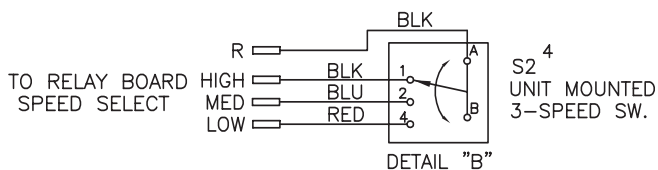

FIGURE 30 - EXAMPLE WIRING DIAGRAM (CONT'D)

THIS PAGE INTENTIONALLY LEFT BLANK

SECTION 3 - NORMAL OPERATION & PERIODIC MAINTENANCE

GENERAL

Each unit on a job will have its own unique operating environment and conditions that may dictate maintenance schedule for that unit that is different from other equipment on the job. A formal schedule of regular maintenance and an individual unit log should be established and maintained. This will help to achieve the maximum performance and service life of each unit on the job.

Information regarding safety precautions contained in the preface at the beginning of this manual should be followed during any service and maintenance operations.

For more detailed information concerning service operations, consult your Sales Representative or the Factory.

MOTOR/BLOWER ASSEMBLY

The type of fan operation is determined by the control components and their method of wiring, and may vary from unit to unit. Refer to the wiring diagram for each unit for that unit's individual operating characteristics. All motors have internal automatic reset thermal overloads.

Should the assembly require more extensive service, the motor/blower assembly may be removed from the unit to facilitate such operations as motor or blower wheel/housing replacement, etc. The motor/blower assembly is supplied on a slide-out rail system (see *Figure 32 on page 47*). To remove, loosen the two lock nuts at the rack front and slide the blower assembly out. Disconnect the motor electrical plug to fully remove the assembly from the unit. To reinstall the blower, repeat the removal sequence in reverse order. The rear of the blower must catch on the support bracket supplied.

Dirt and dust should not be allowed to accumulate on the blower wheel or housing. This can result in an unbalanced blower wheel condition that can damage a blower wheel or motor. The wheel and housing may be cleaned periodically using a vacuum cleaner and a brush taking care not to dislodge the factory balancing weights on the blower wheel blades.

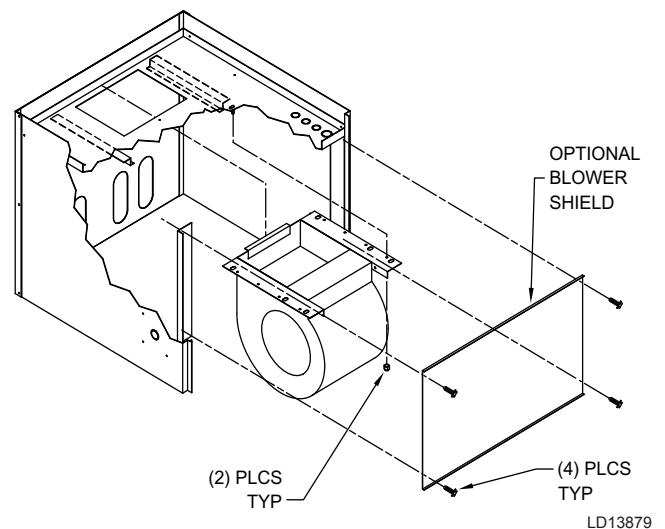

FIGURE 32 - MOTOR/BLOWER ASSEMBLY

COIL

Coils may be cleaned by brushing the entering air face between fins with a soft brush. Brushing should be followed by cleaning with a vacuum cleaner. If a compressed air source is available, the coil may also be cleaned by blowing air through the coil fins from the leaving air face. Vacuuming should again follow this procedure. Units provided with the proper type of air filters, replaced regularly, will still require periodic coil cleaning.

ELECTRIC RESISTANCE HEATER ASSEMBLY

Electric resistance heaters typically require no normal periodic maintenance when unit air filters are changed properly. The two most important operating conditions for an electric heater are proper airflow and proper supply voltage. High supply voltage and/or poorly distributed or insufficient airflow over the element will result in element overheating. This condition may result in the heater cycling on the high limit thermal cutout. Open coil strip heaters have an automatic reset switch with a back-up high limit thermal switch. Automatic reset switches are as the name implies; they reset automatically after the heater has cooled sufficiently. High limit thermal switches must be replaced once the circuit has been broken. The high limit thermal cutout device is a safety device only and is not intended for continuous operation. With proper unit application and operation, the high limit thermal cutout will not deactivate the heater. This device only operates when some problem exists and ANY condition that causes high limit cutout

MUST be corrected immediately. High supply voltage also causes excessive amperage draw and may result in tripping of the circuit breaker or blowing of the fuses on the incoming power supply.



Window treatments and drapes must not be positioned in a manner which obstructs the air flow through the return air or discharge grilles.

After proper air flow and supply power are assured, regular filter maintenance is important to provide clean air over the heater. Dirt that is allowed to deposit on the heating element will cause hot spots and eventual element burn-through. These hot spots will normally not be enough to trip the thermal high limit and may not be evident until actual heater element failure. Heaters may be serviced through the unit's electrical section (see *Figure 33* on page 48). To remove heater, disconnect unit power, remove heater connecting wiring and the element mounting screws.

ELECTRICAL WIRING & CONTROLS

The electrical operation of each unit is determined by the components and wiring of the unit and may vary from unit to unit. Consult the wiring diagram for the actual type and number of controls provided on each unit.

The integrity of all electrical connections should be verified at least twice during the first year of operation. Afterwards, all controls should be inspected regularly for proper operation. Some components may experience erratic operation or failure due to age. Wall thermostats may also become clogged with dust and lint and should be periodically inspected and cleaned to provide reliable operation.

When replacing any components such as fuses, contactors, or relays, use only the exact type, size, and voltage component as furnished from the factory. Any deviation without factory authorization could result in personnel injury or damage to the unit and will void all factory warranties. All repair work should be done in such a manner as to maintain the equipment in compliance with governing codes and ordinances or testing agency listings. More specific information regarding the use and operating characteristics of the standard controls offered by this manufacturer is contained in other manuals.

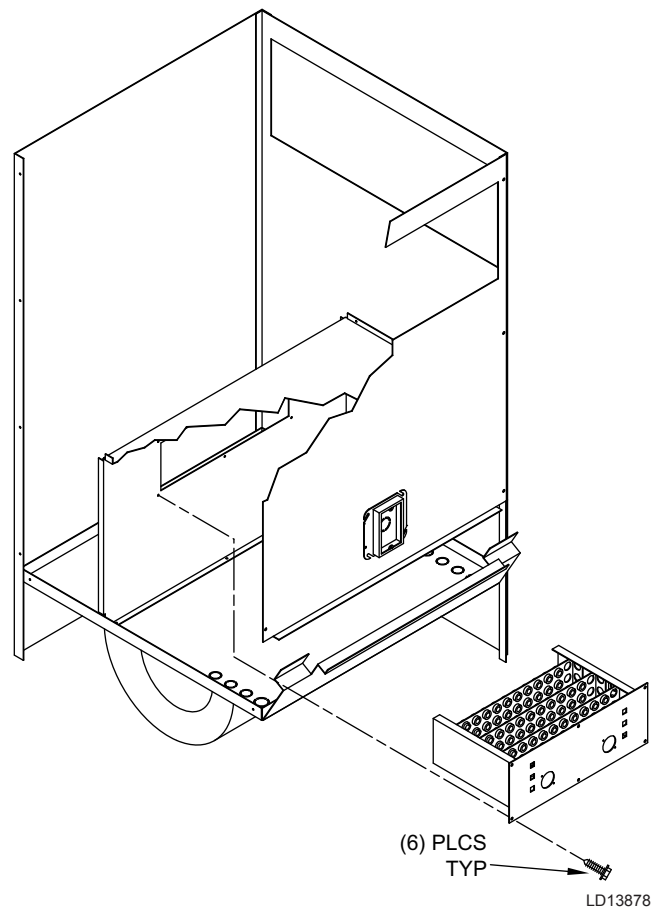

FIGURE 33 - ELECTRIC HEAT

VALVES & PIPING

With the exception of strainers, no formal maintenance is required on the valve package components most commonly used with fan coil units. During normal periodic maintenance, the valve packages may be visually inspected for possible leaks.

Valve packages with strainers should have the strainers cleaned after startup. The strainers may require cleaning several times immediately after startup until the system is thoroughly cleaned and stabilized. After that, a schedule should be determined for regular inspection of the strainers.

In the event that a valve or component should need replacement, the same precautions taken during the initial installation to protect the components from excessive heat should be observed during replacement.

FILTERS, THROWAWAY

The type of throwaway filter most commonly used on fan coil units should be replaced on a regular basis. The time interval between each replacement should be established based on regular inspection of the filter and should be recorded in the log for each unit. Refer to the product catalog for the recommended filter size for each product type and size. If the replacement filters are not purchased from the factory, the filters used should be the same type and size as that furnished from or recommended by the factory. Consult the factory for applications using filter types other than the factory standard or optional product. Dirty filters are the cause of the most common system performance complaints. It is essential that filters be serviced on a regular basis.

DRAIN

The drain should be checked before initial start-up and at the beginning of each cooling season to assure that the drain trap and line are clear. If it is clogged, steps should be taken to clear the debris so that condensate will flow easily.

Periodic checks of the drain should be made during the cooling season to maintain a free flowing condensate. Should the growth of algae and/or bacteria be a concern, consult an air conditioning and refrigeration supply organization familiar with local conditions for chemicals available to control these agents. The drain trap is a flexible rubber hose. It is secured to the drain pan and riser with clamps and is easily removable for service.

OPTIONAL REMOVABLE DRAIN PAN

An optional removable drain pan is available for easy service and cleaning (see *Figure 34 on page 49*). To remove the pan, disconnect the drain p-trap by loosening the hose clamp under the pan. Remove the retainer plate at the front of the pan and slide the pan out of its track. Clean or service pan as appropriate. Reinstall pan in reverse sequence. Retainer plate must be installed for proper operation.

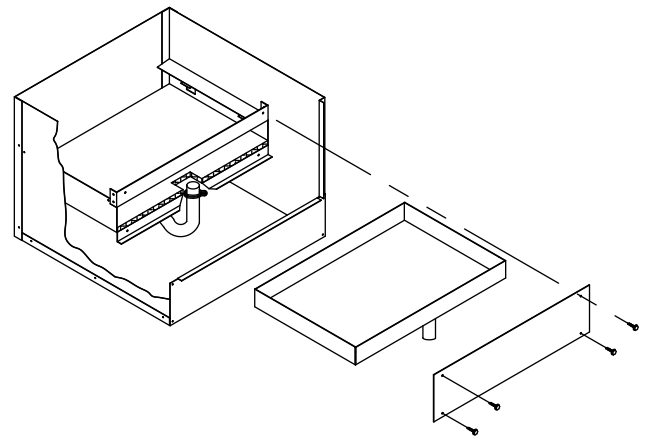

FIGURE 34 - DRAIN PAN REMOVAL

REPLACEMENT PARTS

Factory replacement parts should be used wherever possible to maintain the unit performance and operating characteristics and the testing agency listings. Replacement parts may be purchased through the local Sales Representative.

Contact the local Sales Representative or the factory before attempting any unit modifications. Any modifications not authorized by the factory could result in personnel injury and damage to the unit and could void all factory warranties.

When ordering parts, the following information must be supplied to ensure proper part identification:

1. Complete unit model number.
2. Unit hand connection (right or left hand) while facing into the air stream.
3. Complete part description including any numbers.

On warranty replacements, in addition to the information previously listed, the Factory Order Number (CO#) that appears on the unit nameplate, is required. Contact the factory for authorization to return any parts such as defective parts replaced in warranty. All shipments returned to the factory **MUST** be marked with a Return Authorization Number, which is provided by the factory.

All equipment and components sold through the Parts Department are warranted under the same conditions as the standard manufacturers' warranty with the exception that the warranty period is 12 months unless the component is furnished as warranty replacement. Parts furnished as warranty replacements are warranted for the remaining term of the original unit warranties.

THIS PAGE INTENTIONALLY LEFT BLANK

SECTION 4 - INSPECTION, INSTALLATION & START-UP CHECKLIST

RECEIVING & INSPECTION

DATE:

BY:

- Unit Received Undamaged
- Unit Received Complete As Ordered
- Unit Arrangement Correct
- Unit Structural Support Complete & Correct

HANDLING & INSTALLATION

- Unit Mounted Level & Square
- Proper Access Provided For Unit & Accessories
- Proper Electrical Service Provided
- Proper Overcurrent Protection Provided
- Proper Service Switch/Disconnect Provided
- Proper Chilled Water Line Size To Unit
- Proper Hot Water Line To Unit
- All Services To Unit In Code Compliance
- All Shipping Screws & Braces Removed

COOLING/HEATING CONNECTIONS

- Protect Valve Package Components From Heat
- Mount Valve Packages
- Connect Field Piping To Unit
- Pressure Test All Piping For Leaks
- Install Drain Line & Traps As Required
- Insulate All Piping As Required

DUCTWORK CONNECTIONS

- Install Ductwork, Fittings & Grilles As Required
- Proper Supply & Return Grille Type & Size Used
- Control Outside Air For Freeze Protection
- Insulate All Ductwork As Required

ELECTRICAL CONNECTIONS

- Refer To Unit Wiring Diagram
- Connect Incoming Power Service or Services
- Electrical Service of Correct Voltage and Ampacity to Support Unit Operating Loads
- All Field Wiring Installed With Code Compliance
- Check All Wiring For Secure Connections

UNIT START-UP

DATE:

BY:

- General Visual Unit & System Inspection _____
- Record Electrical Supply Voltage _____
- Record Ambient Temperature _____
- Close All Unit Isolation Valves _____
- Flush Water Systems _____
- Fill Systems With Water/Refrigerant _____
- Vent Water Systems As Required _____
- All Ductwork & Grilles In Place _____
- All Unit Panels & Filters In Place _____
- Start Fans, Etc. _____
- Check For Overload Condition Of All Units _____
- Check All Ductwork & Units For Air Leaks _____
- Balance Air Systems As Required _____
- Record All Final Settings For Future Use _____
- Check Piping & Ductwork For Vibration _____
- Check All Dampers For Proper Operation _____
- Verify Proper Cooling Operation _____
- Verify Proper Heating Operation _____
- Reinstall All Covers & Access Panels _____

SERVICE INTERVALS (record dates service performed):

Filters: _____

Drain Pan: _____

Motor/Blower: _____

Coil: _____

Controls: _____

General: _____

SECTION 5 - TROUBLESHOOTING

SYMPTOM	POSSIBLE CAUSE	CORRECTIVE ACTION
NO UNIT OPERATION	No power to unit.	Apply proper power to unit.
	Improper power to unit.	Apply proper power to unit and check for damaged components and/or blown fuses, if furnished.
	Power distribution panel switch or circuit breaker in "OFF" position.	Turn power distribution panel switch or circuit breaker to "ON" position.
	Unit toggle or door interlock disconnect switch in "OFF" position.	Turn unit toggle or door interlock disconnect switch to "ON" position.
	Fan switch or thermostat system switch in "OFF" position.	Turn fan switch or thermostat system switch to "ON" position.
	Blown or defective unit main fuse, if furnished.	Check for possible defective component or improper wiring, and replace fuse.
	Blown or defective fan motor fuse, if furnished.	Check for possible defective component or improper wiring, and replace fuse.
	Defective toggle, door interlock, fan, or thermostat system switch.	Momentarily jumper suspected component to simulate closed contacts and achieve unit operation. Replace defective device with known good part.
	Loose or improper wiring from power distribution and/or remote mounted control devices.	Verify all wiring connections and terminations, and verify proper wiring of all incoming power devices and remote mounted controls.
UNIT BLOWS MAIN UNIT OR FAN MOTOR FUSE WHEN POWER IS APPLIED TO UNIT	Defective or improperly wired component.	Using a battery powered continuity tester, check for shorted or grounded components starting at incoming power. Note position of all controls during various component checks. Caution: some voltages have isolated common which may not show a short to chassis ground. Be sure to isolate each control to eliminate faulty reading through a parallel wired component.
FAN DOES NOT RUN WITH POWER TO UNIT	Fan switch in "OFF" position.	Turn fan switch to "ON" position.
	Thermostat system switch in "OFF" position.	Turn thermostat system switch to "ON" position.
	Remote "start/stop" switch in "OFF" position.	Turn remote "start/stop" switch to "ON" position.
	Loose or improper wiring from fan switch or thermostat to unit.	Verify all wiring connections and terminations, and verify proper wiring of all control devices.
	Loose or improper wiring from remote "start/stop" switch to unit "start/stop" relay.	Verify all wiring connections and terminations, and verify proper wiring of remote "start/stop" switch.
	Defective fan switch.	Momentarily jumper fan switch to each fan speed wire to simulate proper fan switch operation. Replace defective fan switch.
	Defective "start/stop" relay.	Momentarily jumper "start/stop" relay to simulate proper relay operation. Replace defective "start/stop" relay.
	Defective fan motor.	Verify proper fan switch operation and replace defective fan motor.

SYMPTOM	POSSIBLE CAUSE	CORRECTIVE ACTION
FAN MOTOR HUMS AND/OR GETS HOT, BUT RUNS AT REDUCED SPEED OR NOT AT ALL	Improper power applied to unit.	Apply proper power to unit.
	Defective motor capacitor.	Replace with known good capacitor.
	Defective fan motor.	Replace defective motor.
	Blower wheel jammed in housing.	Reposition blower wheel for proper alignment in housing, or replace if damaged.
	Foreign object in blower wheel.	Remove foreign object and replace blower wheel if damaged.
FAN RUNS BUT VIBRATES	Blower wheel dirty.	Remove and clean blower wheel taking care not to remove or reposition balance weights.
	Blower wheel bent.	Replace blower wheel.
	Blower wheel out of balance.	Replace blower wheel.
	Foreign object in blower wheel.	Remove foreign object and replace blower wheel if damaged.
	Loose motor mount screws.	Verify proper motor and blower wheel position and tighten motor mount screws. Do not crush mounting grommets.
	Broken motor mount frame or mounting screws.	Replace motor or mounting screws.
FAN RUNS BUT BLOWER WHEEL RUBS HOUSING	Bent blower wheel.	Replace blower wheel.
	Blower wheel not positioned properly on motor shaft.	Check for damage to blower wheel. Reposition blower wheel on motor shaft or replace as required.
FAN RUNS BUT AIR DELIVERY IS LOW	Incorrect fan speed has been selected.	Reselect proper fan speed as required.
	Dirty air filter.	Replace air filter.
	Dirty coil.	Clean coil.
	Obstruction in ductwork.	Check for improperly positioned balancing or fire dampers. Check for fallen duct liner. Repair as required.
	Actual E.S.P. higher than design.	Check installation for proper supply and/or return grilles, and compliance with plans and specifications.
FAN RUNS BUT NO COOLING/ HEATING. (HYDRONIC UNITS)	No chilled/hot water flow in system.	Establish chilled/hot water flow in system as required.
	Unit isolation valves closed.	Open unit isolation valves.
	Debris in water piping blocking flow.	Locate and clear debris from water piping as required.
	Plugged strainer on units so equipped.	Clean or remove strainer screen as required.
	Riser or main flushing loop open.	Close flushing loop valve as required.
	Loose or improper wiring from thermostat to control valve.	Verify all wiring connections and terminations, and verify proper wiring of thermostat.
	Defective thermostat.	Momentarily jumper thermostat contacts to simulate proper operation. Replace thermostat as required.
	Defective control valve actuator.	Manually place control valve in "open" position using lever on actuator housing. Replace actuator as required.
	Improper aquastat operation on units so equipped.	Verify proper aquastat position and operation. Replace as required.

SYMPTOM	POSSIBLE CAUSE	CORRECTIVE ACTION
FAN RUNS BUT NO HEATING. (ELECTRIC HEAT UNITS)	No power to electric heat circuit on units with dual point power.	Establish power to electric heat circuit.
	Loose or improper wiring from thermostat to electric heat contactor.	Verify all wiring connections and terminations, and verify proper wiring of thermostat.
	Loose or improper wiring of electric heat element.	Verify all wiring connections and terminations, and verify proper wiring of electric heat element.
	Defective electric heat contactor.	With electric heat contactor energized, verify proper voltage on contactor load terminals. Replace as required.
	Tripped or defective primary high limit switch.	Turn thermostat to lowest set point and allow fan to run 10-15 minutes for limit switch to cool and reset. Then turn thermostat to highest set point and check for proper heating operation. If high limit trips again, check for the following conditions: improper voltage to heater element; obstructed fan or unit outlet reducing air flow over heater element; dirty or defective heater element causing hot spot. If heater does not operate after sufficient time for limit switch to cool, disconnect power and check continuity across primary high limit switch. Replace if defective.
	Tripped secondary high limit switch.	Secondary high limit switches are designed to trip only during extreme failure conditions. Contact factory before attempting any corrective action.
	Defective thermostat.	Momentarily jumper thermostat contacts to simulate proper operation. Replace thermostat as required.
	Defective electric heat element.	Disconnect power and check continuity through heat element. Replace as required.
	Improper aquastat or change over relay operation on units so equipped. (Note: electric heat will not operate when hot water is present at the unit.)	Verify proper aquastat position on piping, and verify proper aquastat and change over relay operation. Replace as required.

TROUBLESHOOTING GUIDE FOR FAN COIL RELAY BOARD

- Ensure no wires are floating loosely in product. Verify all wires are connected on relay board.
- Measure input voltage on relay board as indicated below

P1–P2 = 115V
 P1–P3 = 208V
 P1–P4 = 230V
 P1–P5 = 277V

P7–P6 = 115V
 P8–P6 = 208V
 P9–P6 = 230V
 P10–P6 = 277V

- Ensure "MTR PWR" is connected to correct voltages (115V/P7 or 208V/P3 or 230V/P4 or 277V/P5). See *Figure 35 on page 56*.

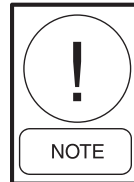

Motor power can only be connected to one voltage.

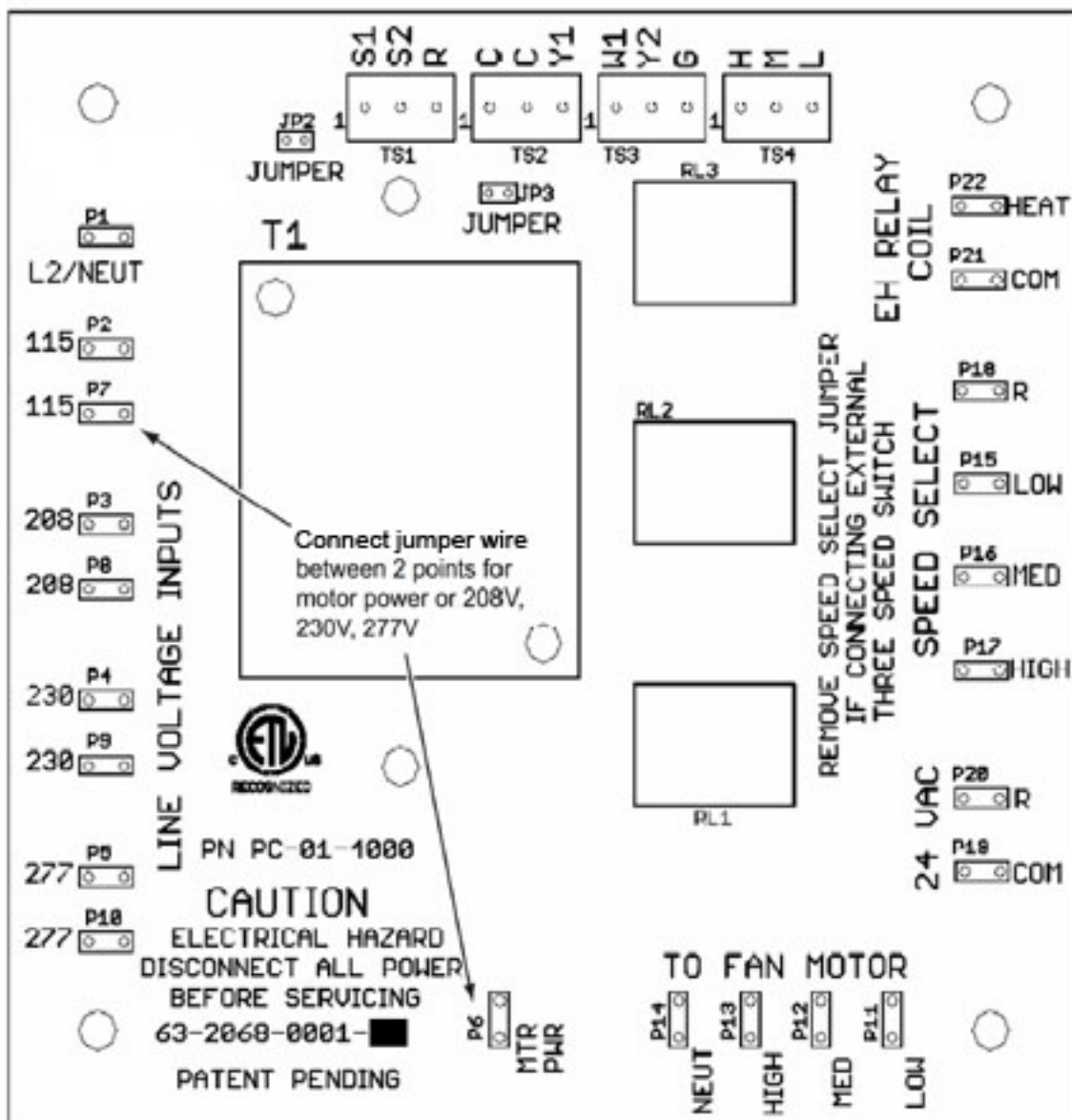

LD19315

FIGURE 35 - FAN COIL RELAY BOARD WITH MOTOR POWER CONNECTIONS

- Verify fan speed will change from High, Medium, and Low by utilizing remote 3 speed switch, thermostat or connecting by P18 to P15, P18 to P16, or P18 to P17. If fan speeds are adjustable, the relay board is producing 24 volts.
- If board is not working, measure 24 volts between P20 and P19. If 24 volts (19-29 VAC) is not present, then measure across terminals SI and R. If 24 volts (19-29 VAC) is not present, then return board to local sales representative.

- Verify plug jumper JP3 (Figure 36 on page 57) is installed or wire (Figure 37 on page 57) is installed between W2 and R.

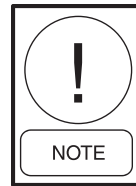

Either JP3 or wire jumper must always be installed unless thermostat drawing indicates otherwise.

JP3 should be removed for single speed operation using "G" terminal.

For thermostat with 3 speed switching, remove JP1 but leave JP3.

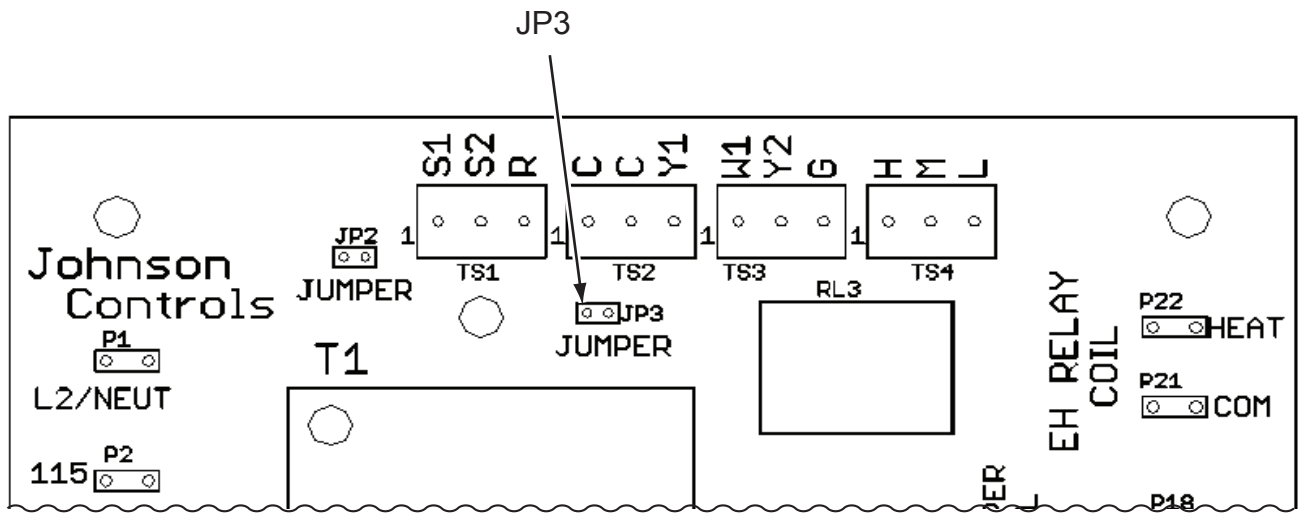

FIGURE 36 - FAN COIL RELAY BOARD (CURRENT)

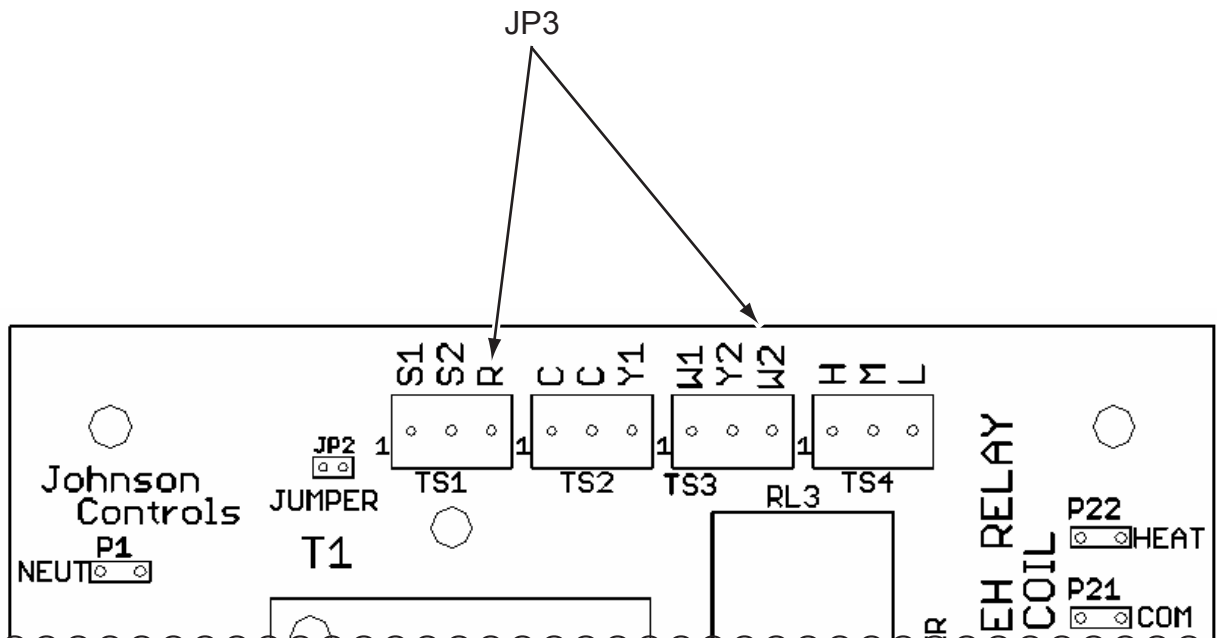

FIGURE 37 - FAN COIL RELAY BOARD (OBSOLETE)

S1 - Common side of transformer. Jumped to "C" (common) through JP2. If application calls for float switch, JP2 is removed and float switch is connected between SI and C.

S2 - Convenience terminal. Not connected to other components on the board. Use for different functions based on application, such as second stage heat control tie point for two stage EH applications, or changeover water valve/aquastat tie point for two stage EH applications, or changeover water valve/aquastat tie point for two pipe changeover applications. May also be used as tie point for "Close" input of modulating hot water valve actuator and "Close" output of thermostat in floating (tristate) water valve applications.

R - Transformer "hot" connection (side of transformer that is not the one used for valve actuator, EH, etc. commons). Control outputs to board should close to "R" to energize (refer to thermostat literature. At least one thermostat, the ENVIRO-TEC T600/ TEC model line is known to use the "R" for valve common but the "C" for fan speed common. This is the only known case in which this occurs. All other thermostats dealt with use the "C" for all device commons).

C - Device common, including onboard speed relays (all terminals "C" and "COM" on board are tied together).

C - Device common.

Y1 - Tie point for chilled water valve actuator control input and thermostat cooling output. Convenience terminal not connected to anything else on board.

W1 - Tie point for hot water valve actuator or first stage EH control input and thermostat heating output. Convenience terminal is tied to P22 "Heat" quick connect for factory termination to EH relay if applicable.

Y2 - Tie point for "Close" input of modulating chilled water valve actuator or second stage chilled water valve actuator control input and thermostat cooling output. Convenience terminal is not connected to anything else on board. Y1 is "Open" output if floating (tristate) chilled water valve actuator is supplied (or used).

G - Connected to "R" through JP3. Use (with JP3 removed) for input from single speed (residential style) thermostats that do not supply three speed fan switching. In these applications, a separate three speed switch may be used with the "H", "M", or "L" inputs of the provided jumper to set a fixed fan speed. If thermostat supports three speed switching, "H", "M", and "L" inputs should be used, and JP3 should remain in place.

H - High speed control input for onboard relay. Parallels the P17 "HIGH" quick connect input. If thermostat or independent three speed switch is used, remove jumper JP1 (female to female quick jumper wire).

M - Medium speed control for onboard relay. Parallels the P16 "MED" quick connect input.

HEAT (P22) - Same functionality as W1 when operating EH.

SECTION 6 - DIMENSIONAL DATA

The drawings in this section are for reference only and should not be used for construction purposes. Reference submittal documents for most current version.

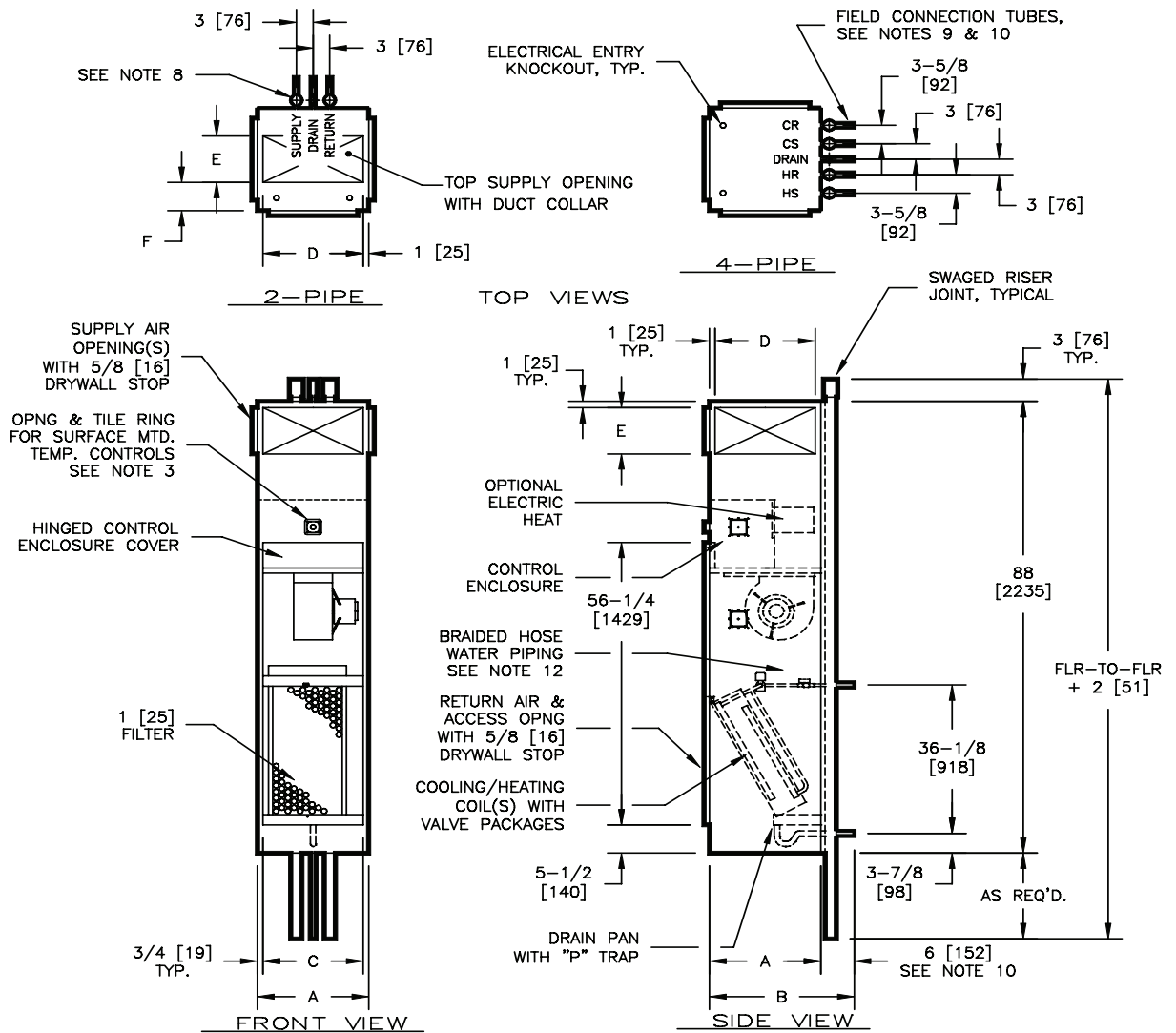

DIMENSIONS - In [mm]

UNIT SIZE	A	B	C	SINGLE/ DOUBLE SUPPLY		F
				D	E	
03 & 04	18 [457]	24 [610]	16-1/2 [419]	16 [406]	8 [203]	6 [152]
06 & 08	20 [508]	26 [660]	18-1/2 [470]	18 [457]	12 [305]	6 [152]
10 & 12	24 [610]	30 [762]	22-1/2 [572]	22 [559]	14 [356]	8 [203]

NOTES:

- All dimensions are Inches [mm]. Metric values are soft conversion.
- All dimensions are ±1/4 [6mm].
- Tile ring is installed on front of unit as shown, and may be moved to left or right side of unit in field. Tile ring is omitted on units with "ADA" control mounting location.
- Wiring from electrical entry point to control enclosure is furnished and installed by others in field.
- Risers available from 3/4" [19mm] to 3" [76mm] diameter with 1/2" [13mm] thick insulation, and 3/4" [19mm] to 2-1/2" [64mm] diameter with 3/4" [19mm] thick insulation.
- All piping and insulation between master and slave units is furnished and installed in the field by others.
- Riser length is 120" [3048mm] max, 100" [2540mm] min.
- Back riser location shown. See arrangement drawings for available unit configurations.
- Slave unit stubout dimension is approximate and varies with riser diameter. Stubout extends approximately 4" from riser tube.
- Water piping connections are 5/8" [16mm] O.D. and drain connection is 7/8" [22mm] O.D.
- Factory mounted risers shown.

74-80007-J

FIGURE 38 - MODEL VHM, VERTICAL CONCEALED MASTER HIGH RISE, FCU, 88" CABINET

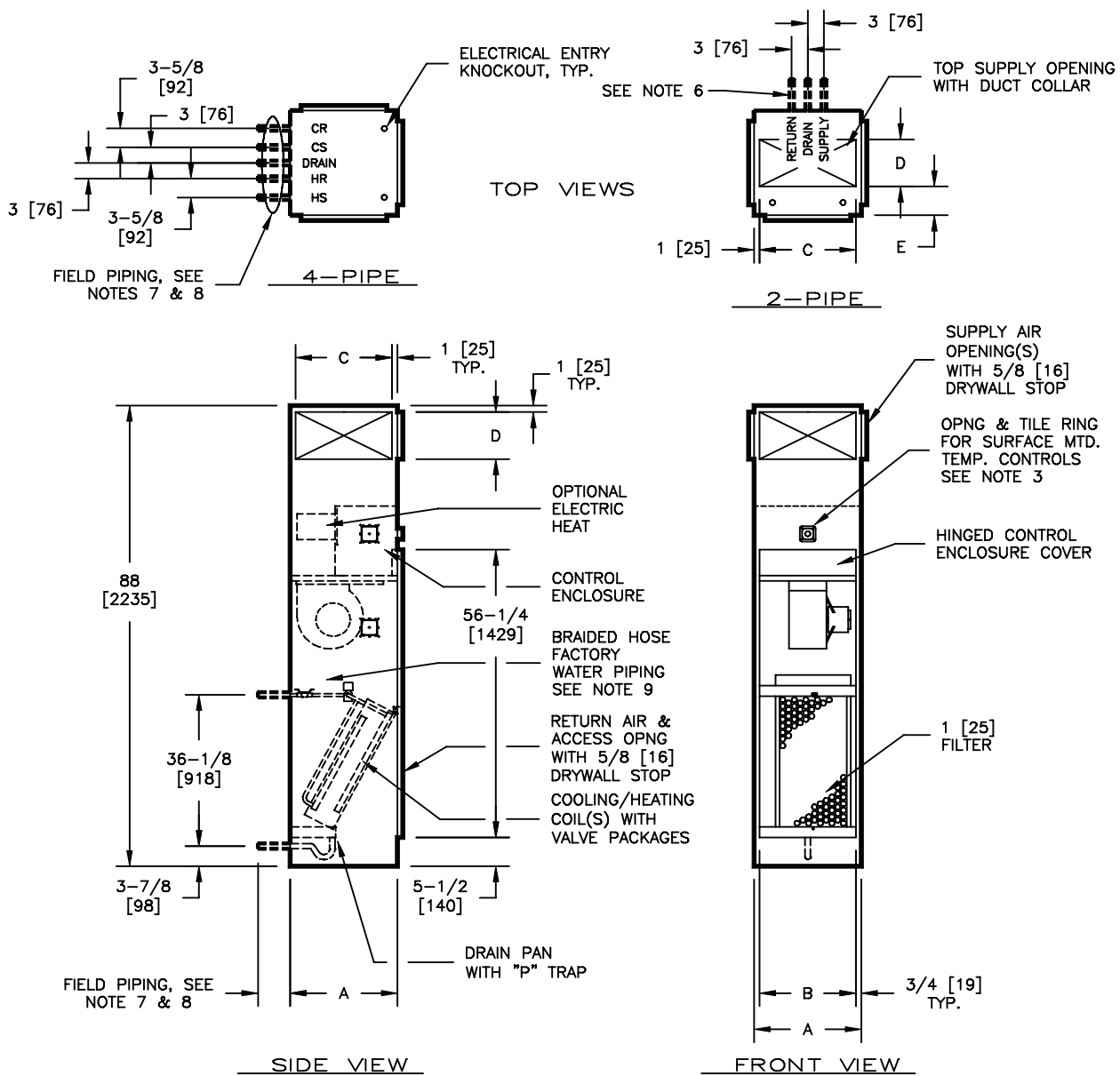

DIMENSIONS - In [mm]

UNIT SIZE	A	B	SINGLE SUPPLY		E
			C	D	
03 & 04	18 [457]	16-1/2 [419]	16 [406]	8 [203]	6 [152]
06 & 08	20 [508]	18-1/2 [470]	18 [457]	12 [305]	6 [152]
10 & 12	24 [610]	22-1/2 [572]	22 [559]	14 [356]	8 [203]

NOTES:

1. All dimensions are Inches [mm]. Metric values are soft conversion.
2. All dimensions are ±1/4 [6mm].
3. Tile ring is installed on front of unit as shown, and may be moved to left or right side of unit in field. Tile ring omitted on units with "ADA" control mounting location.
4. Wiring from electrical entry point to control enclosure is furnished and installed in the field by others.
5. All piping and insulation between slave unit and risers is furnished and installed in the field by others.
6. Back connection location shown. See arrangement drawings for available unit configurations.
7. All coil and drain connections are "retracted" and braced internally for shipment.
8. Coil connections are 5/8" [16mm] O.D. female sweat. Drain "P-trap" is designed to accept 7/8" [22mm] O.D. copper tube.
9. Slave units are furnished with factory installed shutoff valves and field connection tubes, unless master unit risers are shipped loose. Risers may be shipped separately.

74-80008-J

FIGURE 39 - MODEL VHS, VERTICAL CONCEALED SLAVE HIGH RISE, FCU, 88" CABINET

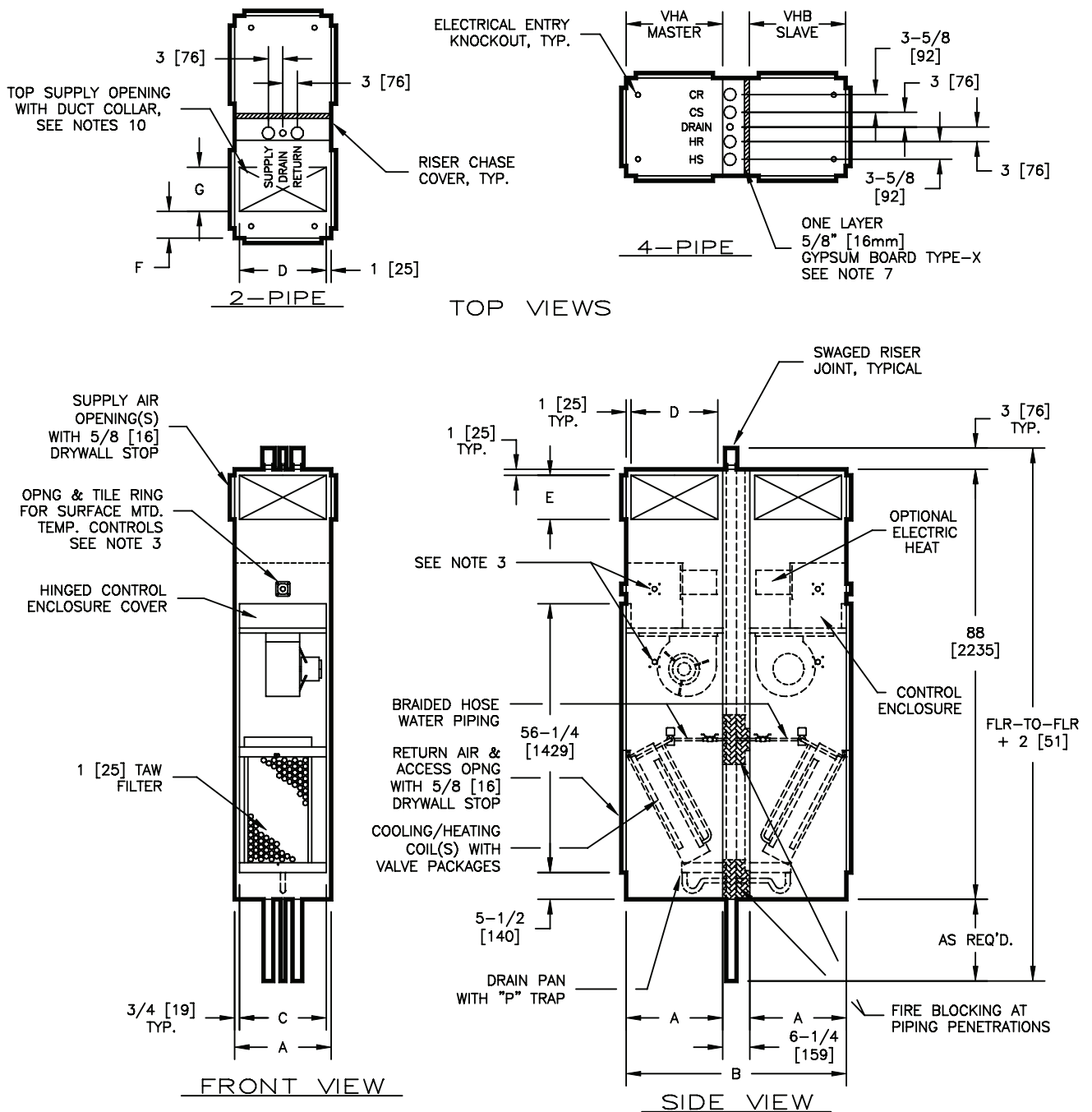

6

NOTES:

1. All dimensions are inches [mm]. Metric values are soft conversion.
2. All dimensions are $\pm 1/4$ [6mm].
3. Thermostat mounting— Tile ring is installed on front of unit as shown and may be moved to left or right side of unit in field.
4. Wiring from electrical entry point to control enclosure is furnished and installed by others in field.
5. Risers available from $3/4$ " [19mm] to $2-1/2$ " [64mm] diameter with $1/2$ " [13mm] or $3/4$ " [19mm] thick insulation.
6. Riser length is 120" [3048mm] max, 100" [2540mm] min.
7. NON-FIRE RATED unit shown with type-X gypsum board at back of slave unit. FIRE RATED units have type-X gypsum board at back of both slave and master units. FIRE RATED unit design has been tested in accordance with UL1479 - Fire Tests Of Through Penetration Fire Stops, and is approved to bear the ETL listing mark for Through Penetration Fire Stop Assemblies.
8. For further fire rating information refer to the Installation Instructions on page 83.
9. See page 62 for dimensions.
10. Refer to page 69, page 70, page 71 & page 72 for vertical Hi-rise Tandem unit configurations.

74-80010-J1

FIGURE 40 - MODEL VHA/VHB, VERTICAL HI-RISE TANDEM FIRE RATED AND NON-FIRE RATED, FCU COMBINATIONS, 88" CABINETS

DIMENSIONS - In. (mm)						VHA/VHB SUPPLY AIR		
VHA (MASTER)	VHB (SLAVE)	A	B	C	D	SINGLE/DOUBLE	TOP	
						E	F	G
03 or 04	03 or 04	18 (457)	42-1/4 (1073)	16-1/2 (419)	16 (406)	8 (203)	6 (152)	8 (203)
03 or 04	06 or 08	20 (508)	46-1/4 (1175)	18-1/2 (470)	18 (457)	12 (305)	6 (152)	12 (305)
03 or 04	10 or 12	24 (610)	54-1/4 (1378)	22-1/2 (572)	22 (559)	14 (356)	8 (203)	14 (356)
06 or 08	03 or 04	20 (508)	46-1/4 (1175)	18-1/2 (470)	18 (457)	12 (305)	6 (152)	12 (305)
06 or 08	06 or 08							
06 or 08	10 or 12	24 (610)	54-1/4 (1378)	22-1/2 (572)	22 (559)	14 (356)	8 (203)	14 (356)
10 or 12	03 or 04	24 (610)	54-1/4 (1378)	22-1/2 (572)	22 (559)	14 (356)	8 (203)	14 (356)
10 or 12	06 or 08							
10 or 12	10 or 12							
See page 61 for notes.								

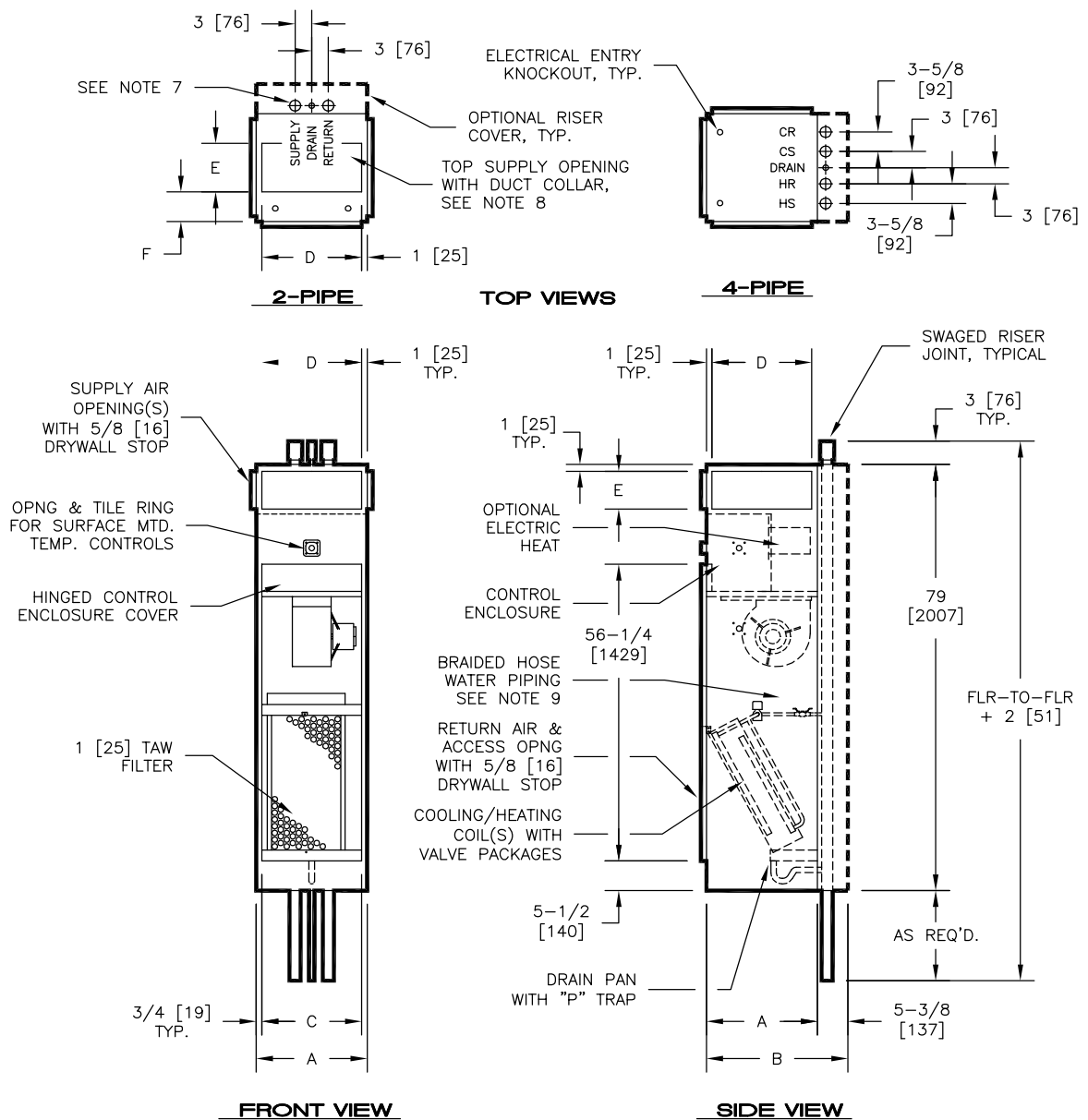

DIMENSIONS - In [mm]

UNIT SIZE	A	B	C	SINGLE SUPPLY		DOUBLE SUPPLY		TOP SUPPLY		F
				D	E	D	E	D	E	
03 & 04	18 [457]	23-3/8 [594]	16-1/2 [419]	16 [406]	8 [203]	16 [406]	8 [203]	16 [406]	8 [203]	6 [152]
06 & 08	20 [508]	25-3/8 [645]	18-1/2 [470]	18 [457]	8 [203]	18 [457]	8 [203]	18 [457]	12 [305]	6 [152]
10 & 12	24 [610]	29-3/8 [746]	22-1/2 [572]	-- [--]	-- [--]	22 [559]	8 [203]	22 [559]	12 [305]	8 [203]

NOTES:

- All dimensions are Inches [mm]. Metric values are soft conversion.
- All dimensions are ±1/4 [6mm].
- Tile ring is installed on front of unit as shown, and may be moved to left or right side of unit in field.
- Wiring from electrical entry point to control enclosure is furnished and installed by others in field.
- Risers available from 3/4" [19mm] to 3" [76mm] diameter with 1/2" [13mm] thick insulation, and 3/4" [19mm] to 2-1/2" [64mm] diameter with 3/4" [19mm] thick insulation.
- Riser length is 111" [2819mm] max, 91" [2311mm] min.
- Back riser location shown. See arrangement drawings for available unit configurations.
- Single supply size 10 and 12 available in top discharge only.
- Factory mounted risers shown.

VH-031

FIGURE 41 - MODEL VH, VERTICAL CONCEALED HIGH RISE FAN COIL UNIT WITH 79" CABINET

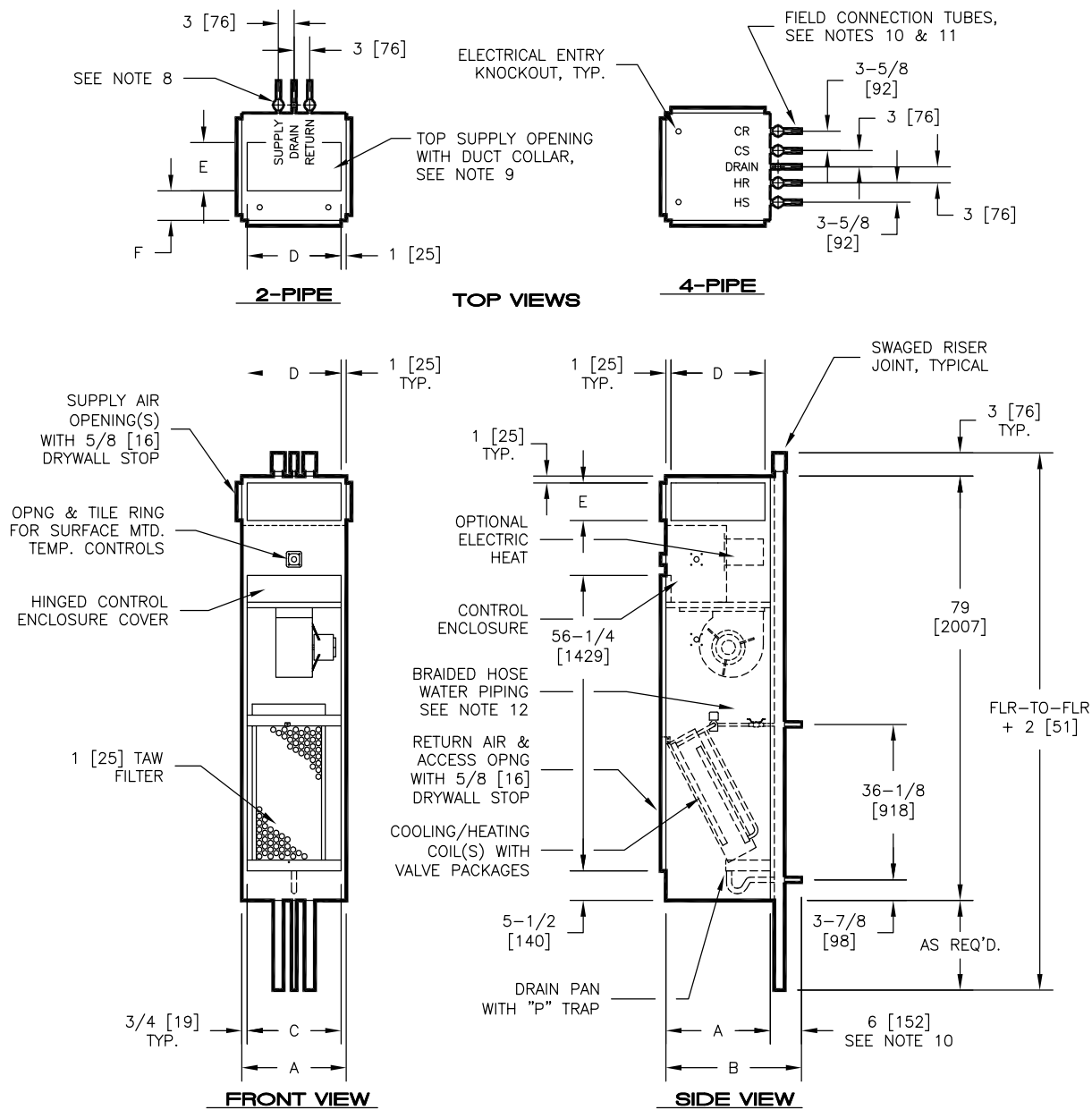

VH-032

DIMENSIONS - In [mm]

UNIT SIZE	A	B	C	SINGLE SUPPLY		DOUBLE SUPPLY		TOP SUPPLY		F
				D	E	D	E	D	E	
03 & 04	18 [457]	24 [610]	16-1/2 [419]	16 [406]	8 [203]	16 [406]	8 [203]	16 [406]	8 [203]	6 [152]
06 & 08	20 [508]	26 [660]	18-1/2 [470]	18 [457]	8 [203]	18 [457]	8 [203]	18 [457]	12 [305]	6 [152]
10 & 12	24 [610]	30 [762]	22-1/2 [572]	-- [--]	-- [--]	22 [559]	8 [203]	22 [559]	12 [305]	8 [203]

NOTES:

- All dimensions are Inches [mm]. Metric values are soft conversion.
- All dimensions are ±1/4 [6mm].
- Tile ring is installed on front of unit as shown, and may be moved to left or right side of unit in field.
- Wiring from electrical entry point to control enclosure is furnished and installed by others in field.
- Risers available from 3/4" [19mm] to 3" [76mm] diameter with 1/2" [13mm] thick insulation, and 3/4" [19mm] to 2-1/2" [64mm] diameter with 3/4" [19mm] thick insulation.
- All piping and insulation between master and slave units is furnished and installed in the field by others.
- Riser length is 111" [2819mm] max, 91" [2311mm] min.
- Back riser location shown. See arrangement drawings for available unit configurations.
- Single supply size 10 and 12 available in top discharge only.
- Slave unit stubout dimension is approximate and varies with riser diameter. Stubout extends approximately 4" from riser tube.
- Water piping connections are 5/8" [16mm] O.D. and drain connection is 7/8" [22mm] O.D.
- Factory mounted risers shown. See drawing VH-105 for shipped loose riser details.

FIGURE 42 - MODEL VHM, VERTICAL CONCEALED MASTER HIGH RISE FAN COIL UNIT WITH 79" CABINET

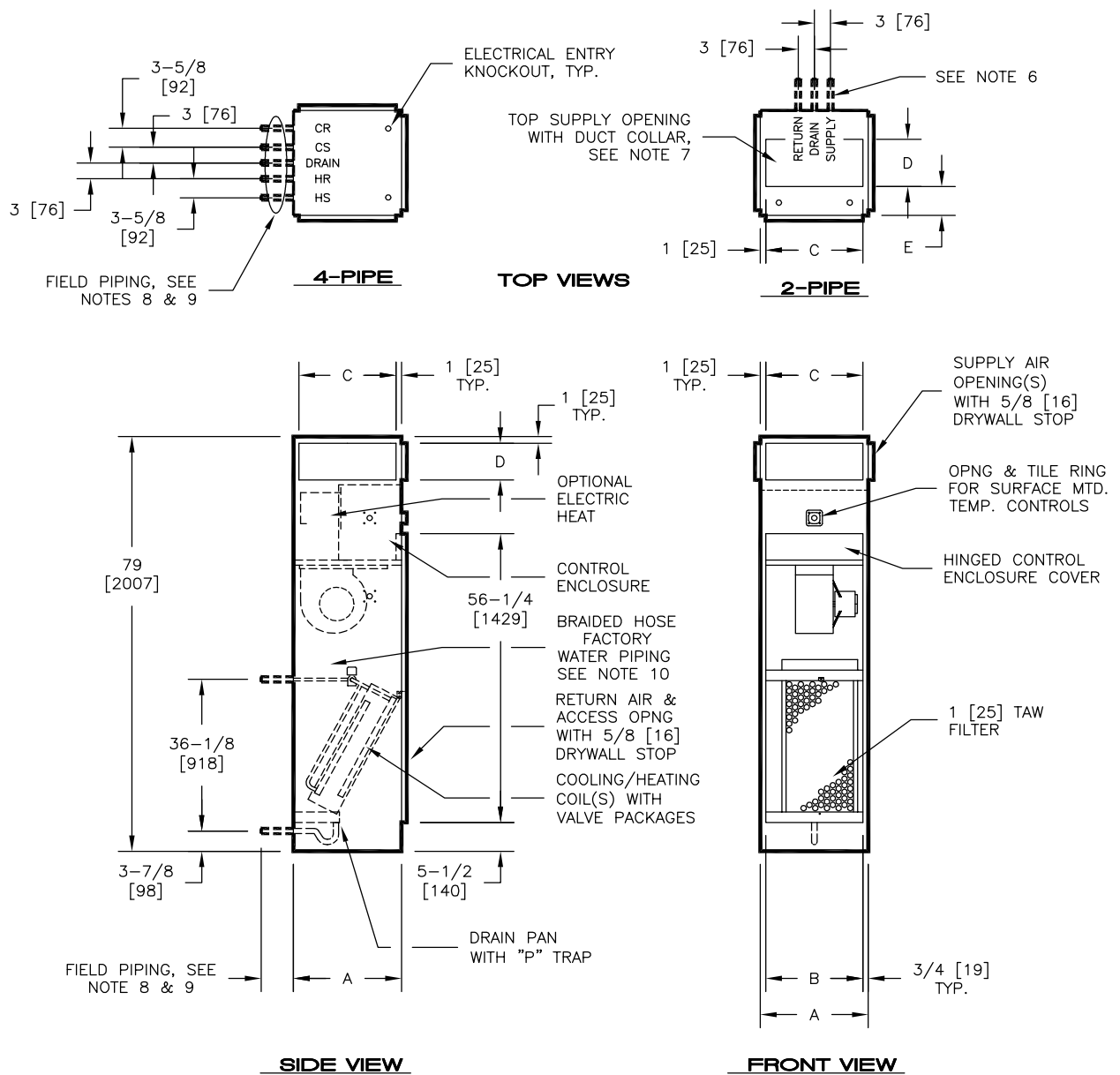

DIMENSIONS - In [mm]

UNIT SIZE	A	B	SINGLE SUPPLY		DOUBLE SUPPLY		TOP SUPPLY		E
			C	D	C	D	C	D	
03 & 04	18 [457]	16-1/2 [419]	16 [406]	8 [203]	16 [406]	8 [203]	16 [406]	8 [203]	6 [152]
06 & 08	20 [508]	18-1/2 [470]	18 [457]	8 [203]	18 [457]	8 [203]	18 [457]	12 [305]	6 [152]
10 & 12	24 [610]	22-1/2 [572]	-- [--]	-- [--]	22 [559]	8 [203]	22 [559]	12 [305]	8 [203]

NOTES:

- All dimensions are Inches [mm]. Metric values are soft conversion.
- All dimensions are ±1/4 [6mm].
- Tile ring is installed on front of unit as shown, and may be moved to left or right side of unit in field.
- Wiring from electrical entry point to control enclosure is furnished and installed in the field by others.
- All piping and insulation between slave unit and risers is furnished and installed in the field by others.
- Back connection location shown. See arrangement drawings for available unit configurations.
- Single supply size 10 and 12 available top discharge only.
- All coil and drain connections are "retracted" and braced internally for shipment.
- Coil connections are 5/8" [16mm] O.D. female sweat. Drain "P-trap" is designed to accept 7/8" [22mm] O.D. copper tube.
- Slave units are furnished with factory installed shutoff valves and field connection tubes, unless master unit risers are shipped loose.

VH-033

FIGURE 43 - MODEL VHS, VERTICAL CONCEALED SLAVE HIGH RISE FAN COIL UNIT WITH 79" CABINET

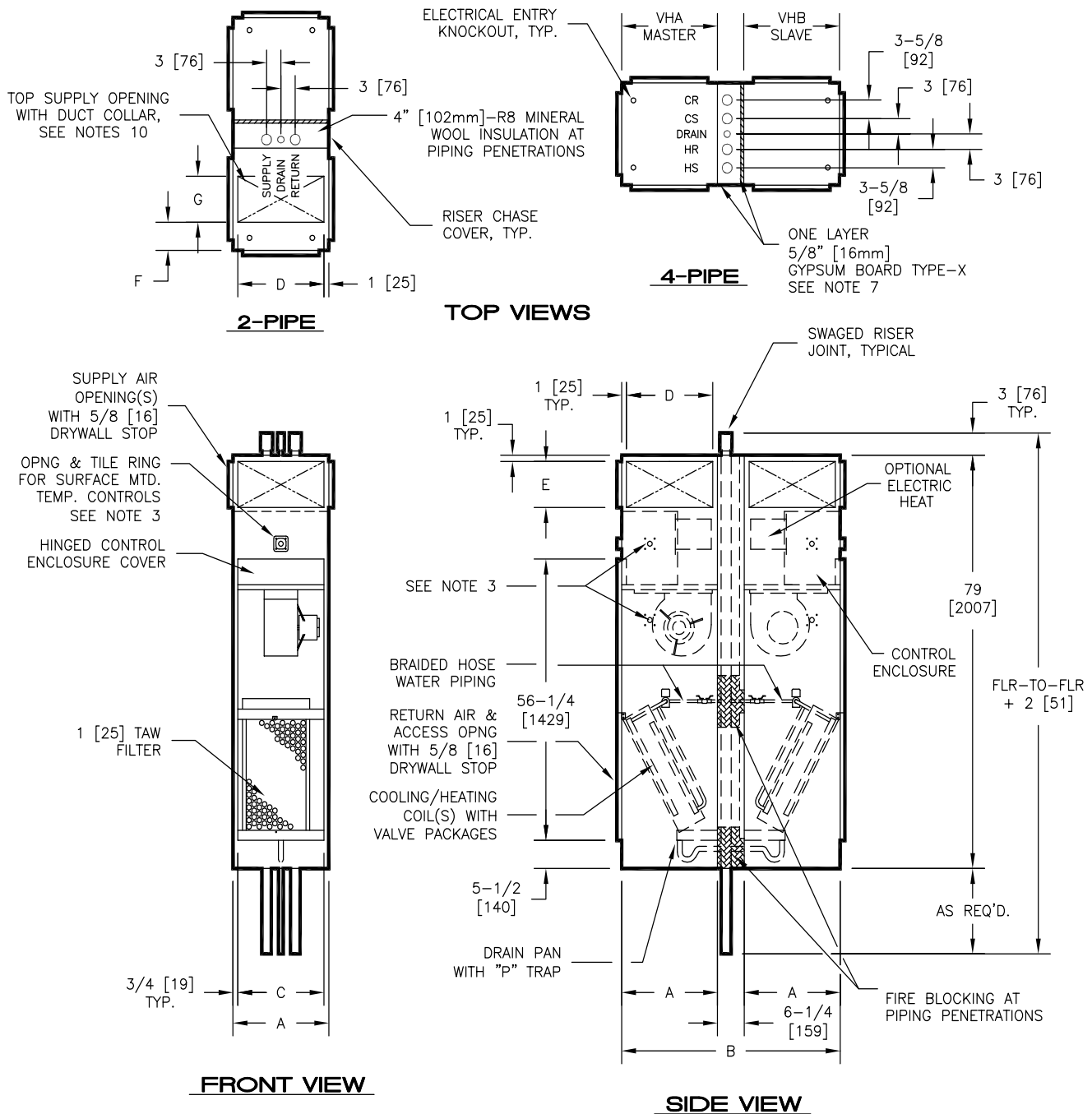

NOTES:

1. All dimensions are Inches [mm]. Metric values are soft conversion.
2. All dimensions are ±1/4 [6mm].
3. Thermostat mounting— Tile ring is installed on front of unit as shown and may be moved to left or right side of unit in field.
4. Wiring from electrical entry point to control enclosure is furnished and installed by others in field.
5. Risers available from 3/4" [19mm] to 2-1/2" [64mm] diameter with 1/2" [13mm] or 3/4" [19mm] thick insulation.
6. Riser length is 115" [2921mm] max, 100" [2540mm] min.
7. NON-FIRE RATED unit shown with type-X gypsum board at back of slave unit. FIRE RATED units have type-X gypsum board at back of both slave and master units. FIRE RATED unit design has been tested in accordance with UL1479 - Fire Tests Of Through Penetration Fire Stops, and is approved to bear the ETL listing mark for Through Penetration Fire Stop Assemblies.
8. For further fire rating information, refer to the Installation Instructions on page 83.
9. See page 67 for dimensions.
10. Refer to page 69, page 70, page 71 & page 72 for vertical Hi-rise Tandem Master & Tandem Slave configurations.

VH-006-1

FIGURE 44 - MODEL VHA/VHB, VERTICAL HI-RISE FIRE RATED AND NON-FIRE RATED FCU COMBINATIONS, 79" CABINETS

DIMENSIONS - In. (mm)						VHA SUPPLY AIR				VHB SUPPLY AIR			
VHA (MASTER)	VHB (SLAVE)	A	B	C	D	SINGLE	DOUBLE	TOP		SINGLE	DOUBLE	TOP	
						E	E	F	G	E	E	F	G
03 or 04	03 or 04	18 (457)	42-1/4 (1073)	16-1/2 (419)	16 (406)	8 (203)	8 (203)	6 (152)	8 (203)	8 (203)	8 (203)	6 (152)	8 (203)
03 or 04	06 or 08	20 (508)	46-1/4 (1175)	18-1/2 (470)	18 (457)	8 (203)	8 (203)	6 (152)	12 (305)	8 (203)	8 (203)	6 (152)	12 (305)
03 or 04	10 or 12	24 (610)	54-1/4 (1378)	22-1/2 (572)	22 (559)	8 (203)	8 (203)	8 (203)	12 (305)		8 (203)	8 (203)	12 (305)
06 or 08	03 or 04	20 (508)	46-1/4 (1175)	18-1/2 (470)	18 (457)	8 (203)	8 (203)	6 (152)	12 (305)	8 (203)	8 (203)	6 (152)	12 (305)
06 or 08	06 or 08												
06 or 08	10 or 12	24 (610)	54-1/4 (1378)	22-1/2 (572)	22 (559)	8 (203)	8 (203)	8 (203)	12 (305)		8 (203)	8 (203)	12 (305)
10 or 12	03 or 04	24 (610)	54-1/4 (1378)	22-1/2 (572)	22 (559)		8 (203)	8 (203)	12 (305)		8 (203)	8 (203)	12 (305)
10 or 12	06 or 08												
10 or 12	10 or 12												

See page 66 for notes.

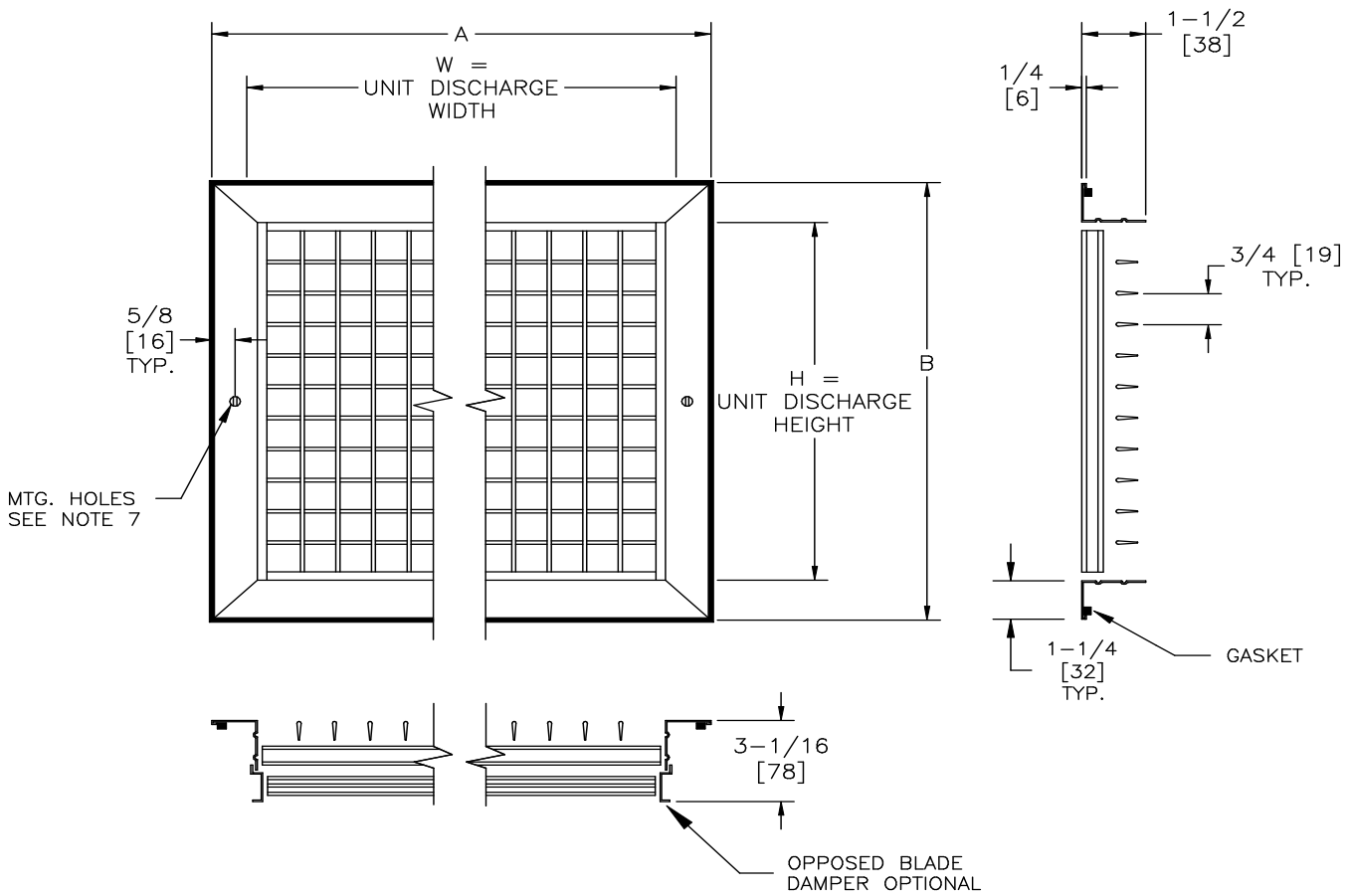

MODEL TYPE	UNIT SIZE	CABT. HGT.	SINGLE/ DOUBLE SUPPLY			
			W	H	A	B
VHC/VHS/VHM & VHA/VHB	03 or 04	STD.	16 [406]	8 [203]	17-11/16 [449]	9-11/16 [246]
		79" CABT.	18 [457]	12 [305]	19-11/16 [500]	13-11/16 [348]
	06 or 08	STD.	18 [457]	8 [203]	19-11/16 [500]	9-11/16 [246]
		79" CABT.	22 [559]	14 [356]	23-11/16 [602]	15-11/16 [398]
	10 or 12	STD.	N/A	N/A	N/A	N/A
		79" CABT.	N/A	N/A	N/A	N/A

MODEL TYPE	UNIT SIZE	CABT. HGT.	SINGLE/ DOUBLE SUPPLY			
			W	H	A	B
VHA/VHB	03 or 04 mated to 06 or 08	STD.	18 [457]	12 [305]	19-11/16 [500]	13-11/16 [348]
		79" CABT.	18 [457]	8 [203]	19-11/16 [500]	9-11/16 [246]
	03 or 04 mated to 10 or 12	STD.	22 [559]	14 [356]	23-11/16 [602]	15-11/16 [398]
		79" CABT.	N/A	N/A	N/A	N/A
	06 or 08 mated to 10 or 12	STD.	22 [559]	14 [356]	23-11/16 [602]	15-11/16 [398]
		79" CABT.	N/A	N/A	N/A	N/A

NOTES:

1. All dimensions are Inches [mm]. Metric values are soft conversion.
2. All dimensions are ±1/4 [6mm].
3. Discharge grilles are shipped loose for field installation.
4. Construction is aluminum frame and blades.
5. Standard finish is powder coat baked enamel. Color is "Pearl White Satin".
6. Installation of grilles on adjacent unit sides may require furring one side away from unit to prevent interference of frames.
7. Mounting hardware included.

74-80020

FIGURE 45 - MODEL VH, VERTICAL HIGH RISE COIL UNIT, ALUMINUM DISCHARGE GRILLE

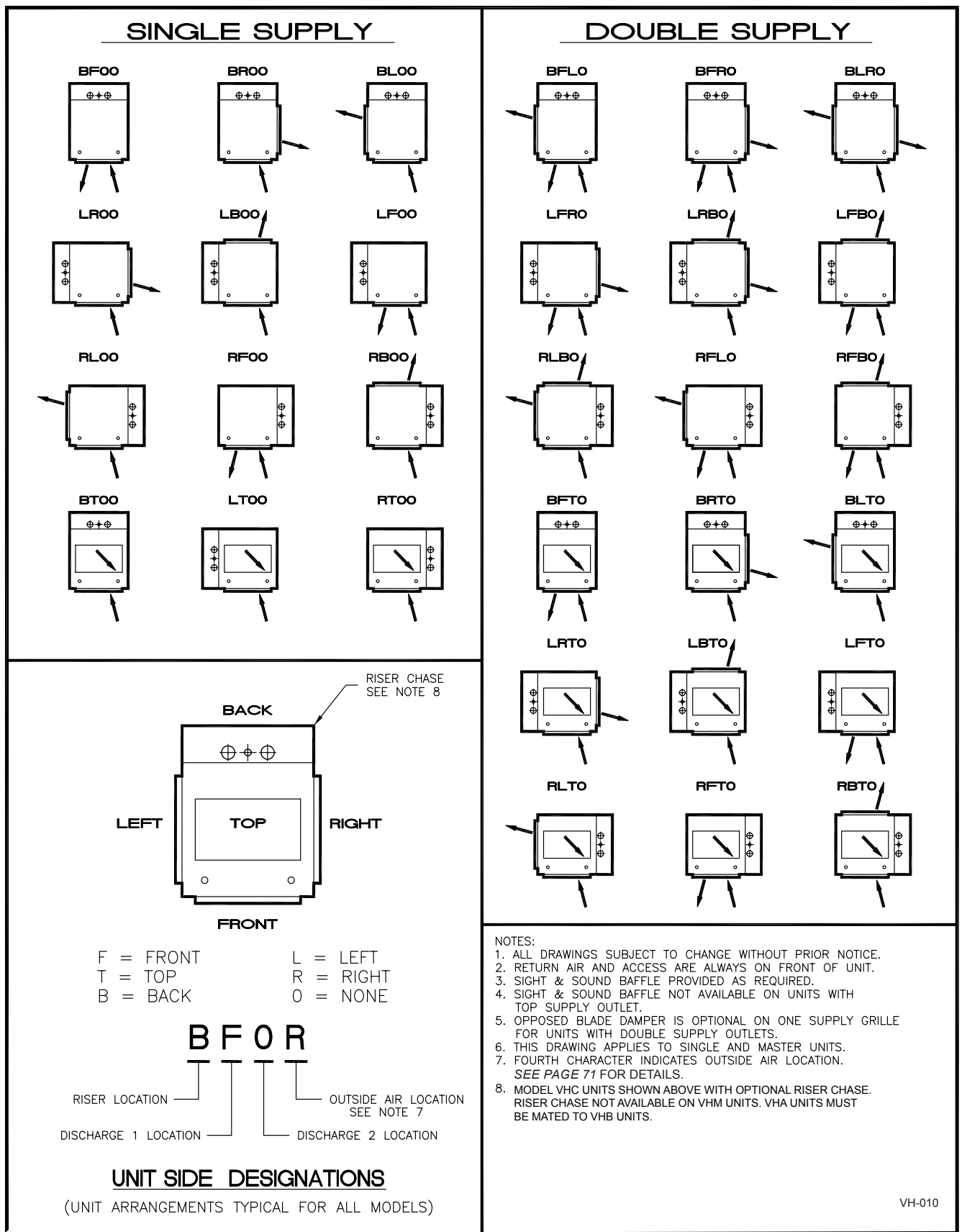

FIGURE 46 - MODEL VHC/VHM/VHA VERTICAL HIGH RISE FAN COIL UNIT ARRANGEMENT DESIGNATIONS

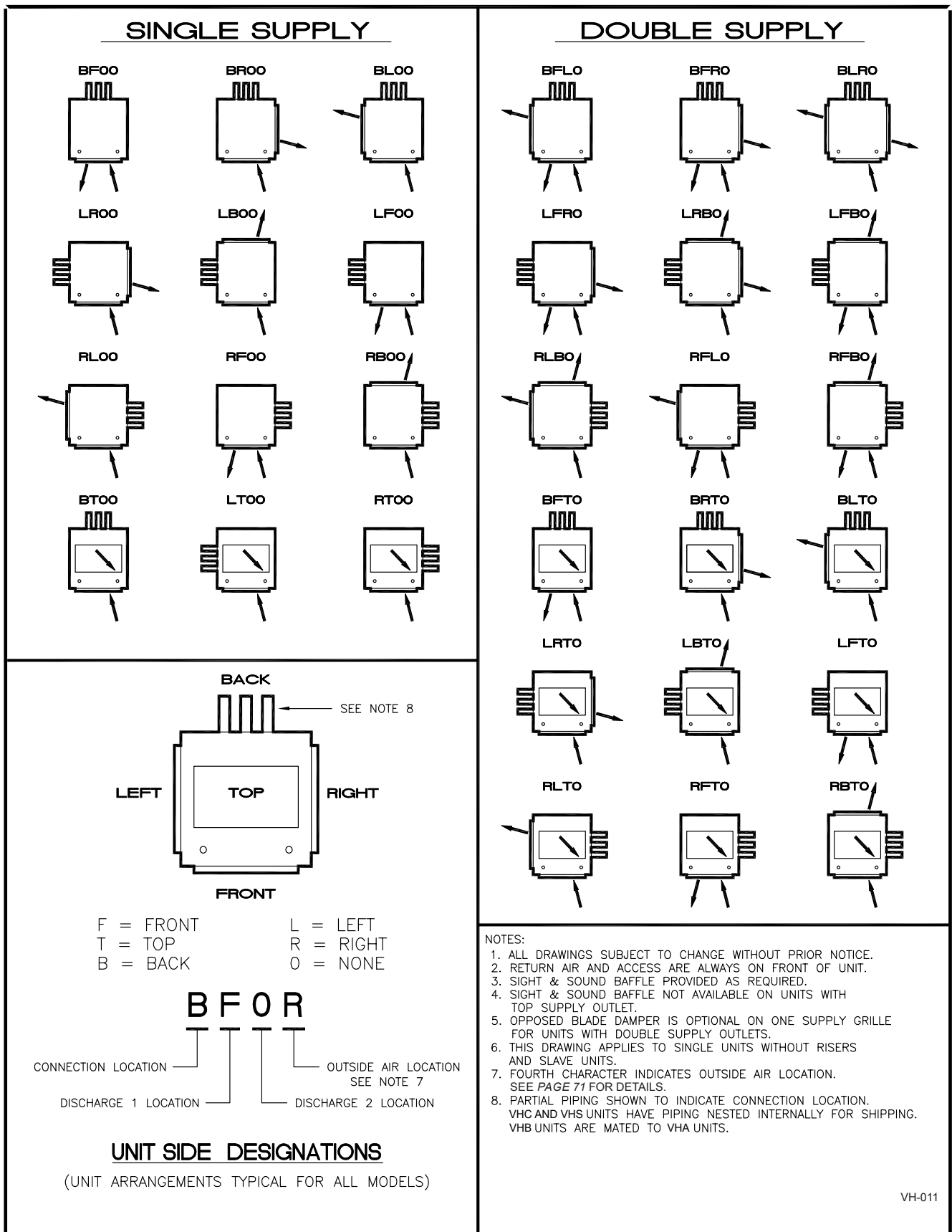
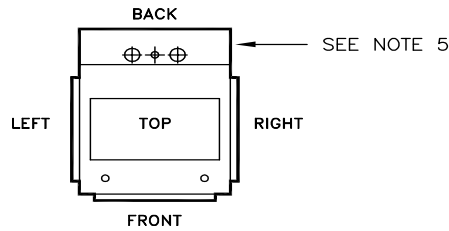
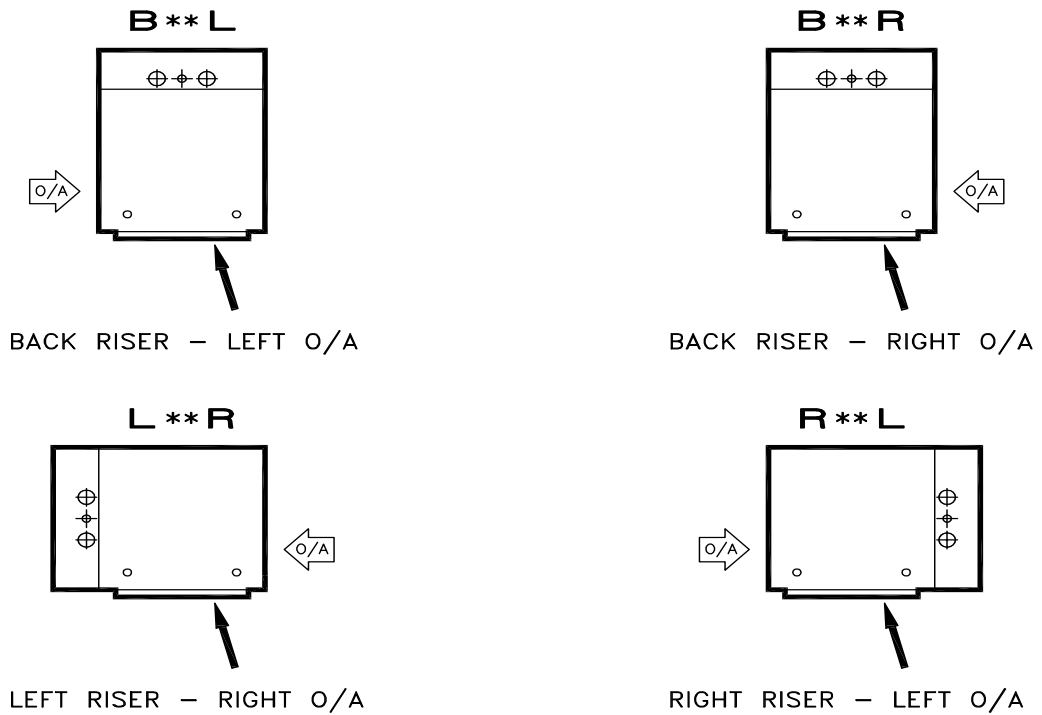
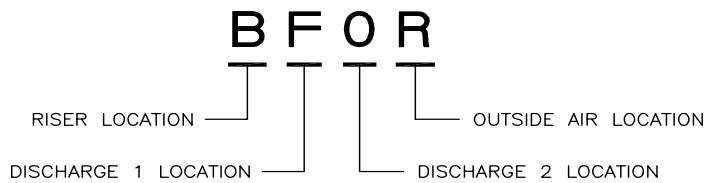

FIGURE 47 - MODEL VHC W/O RISERS & VHS/VHB VERTICAL HIGH RISE FAN COIL UNITS, UNIT ARRANGEMENT DESIGNATIONS



F = FRONT
T = TOP
B = BACK
L = LEFT
R = RIGHT
O = NONE



UNIT SIDE DESIGNATIONS

NOTES:

1. RETURN AIR AND ACCESS ARE ALWAYS ON FRONT OF UNIT.
2. THIS DRAWING SHOWS AVAILABLE RETURN AND OUTSIDE AIR INLET LOCATIONS.
3. SEE ARRANGEMENT DRAWINGS FOR COMPLETE UNIT RISER, SUPPLY, AND RETURN CONFIGURATION DETAILS.
4. OUTSIDE AIR INLET LOCATION IS ALWAYS LAST CHARACTER IN ARRANGEMENT CODE.
5. VHC UNIT WITH OPTIONAL RISER CHASE SHOWN. OUTSIDE AIR LOCATION DESIGNATIONS ARE TYPICAL FOR ALL VH MODELS.

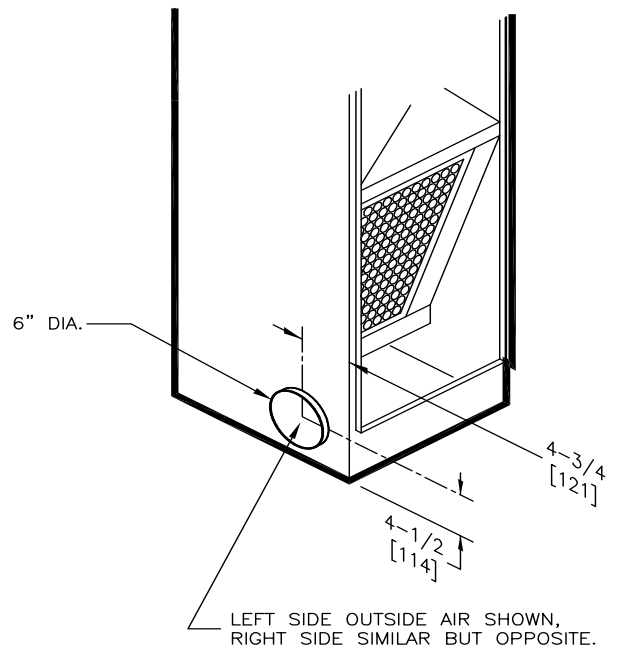

VH-018

FIGURE 48 - MODEL VH VERTICAL HIGH RISE COIL UNIT OUTSIDE INLET DIMENSIONS

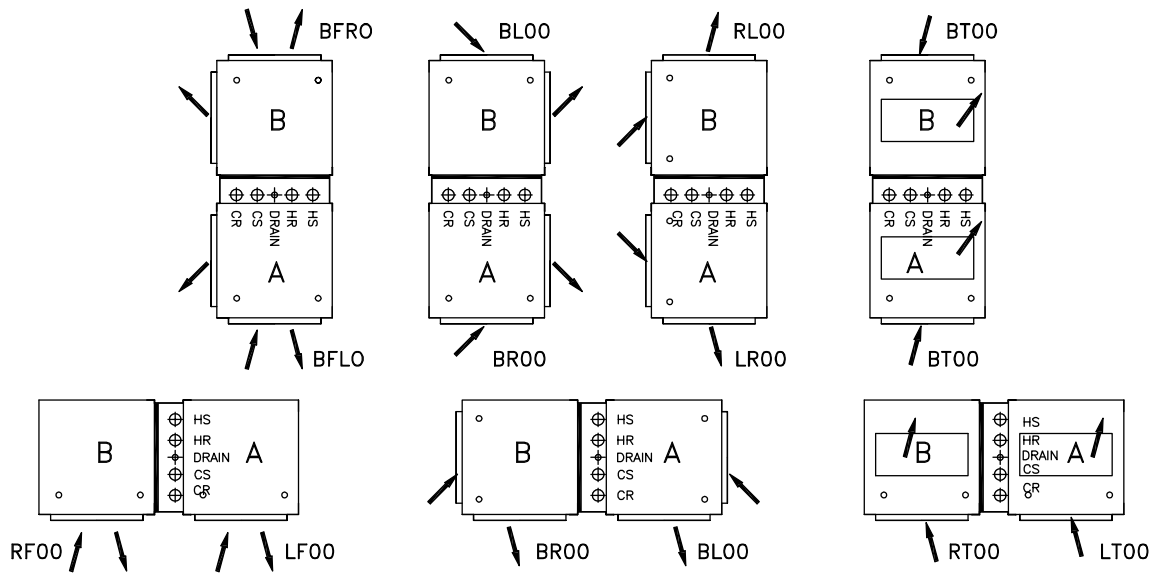

TYPICAL UNIT ARRANGEMENTS

SHOWN ABOVE NON-FIRE RATED

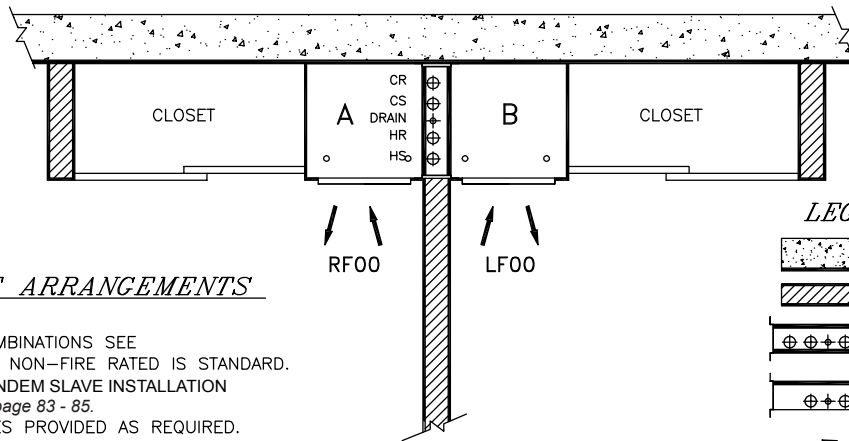

TYPICAL UNIT ARRANGEMENTS

NOTE:

1. FOR OTHER POSSIBLE COMBINATIONS SEE
2. FIRE RATED UNITS SHOWN NON-FIRE RATED IS STANDARD.
3. SEE TANDEM MASTER & TANDEM SLAVE INSTALLATION INSTRUCTIONS ON PAGES page 83 - 85.
4. SIGHT AND SOUND Baffles PROVIDED AS REQUIRED.

LEGEND

- EXTERIOR WALL
- INTERIOR WALL
- TANDEM MASTER & TANDEM SLAVE FIRE RATED
- TANDEM MASTER & TANDEM SLAVE NON-FIRE RATED
- AIR FLOW
- A** MASTER UNIT
- B** SLAVE UNIT

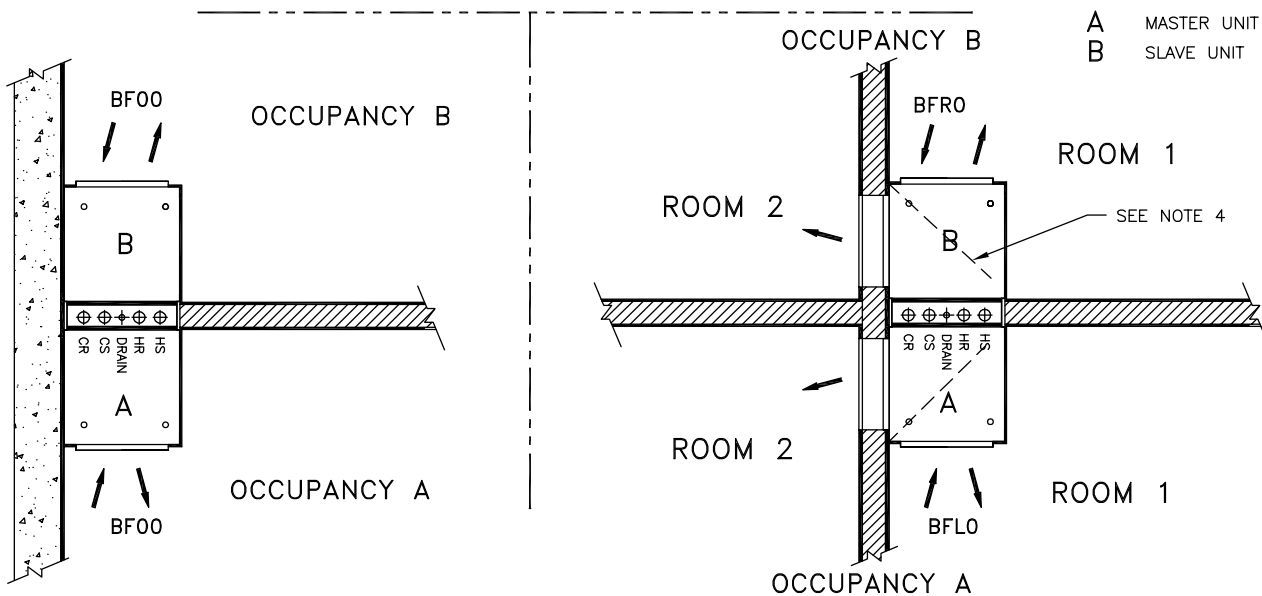

VH-043

FIGURE 49 - MODEL VHM/VHA/VHC TANDEM MASTER & TANDEM SLAVE UNIT CONFIGURATION FAN COIL UNIT

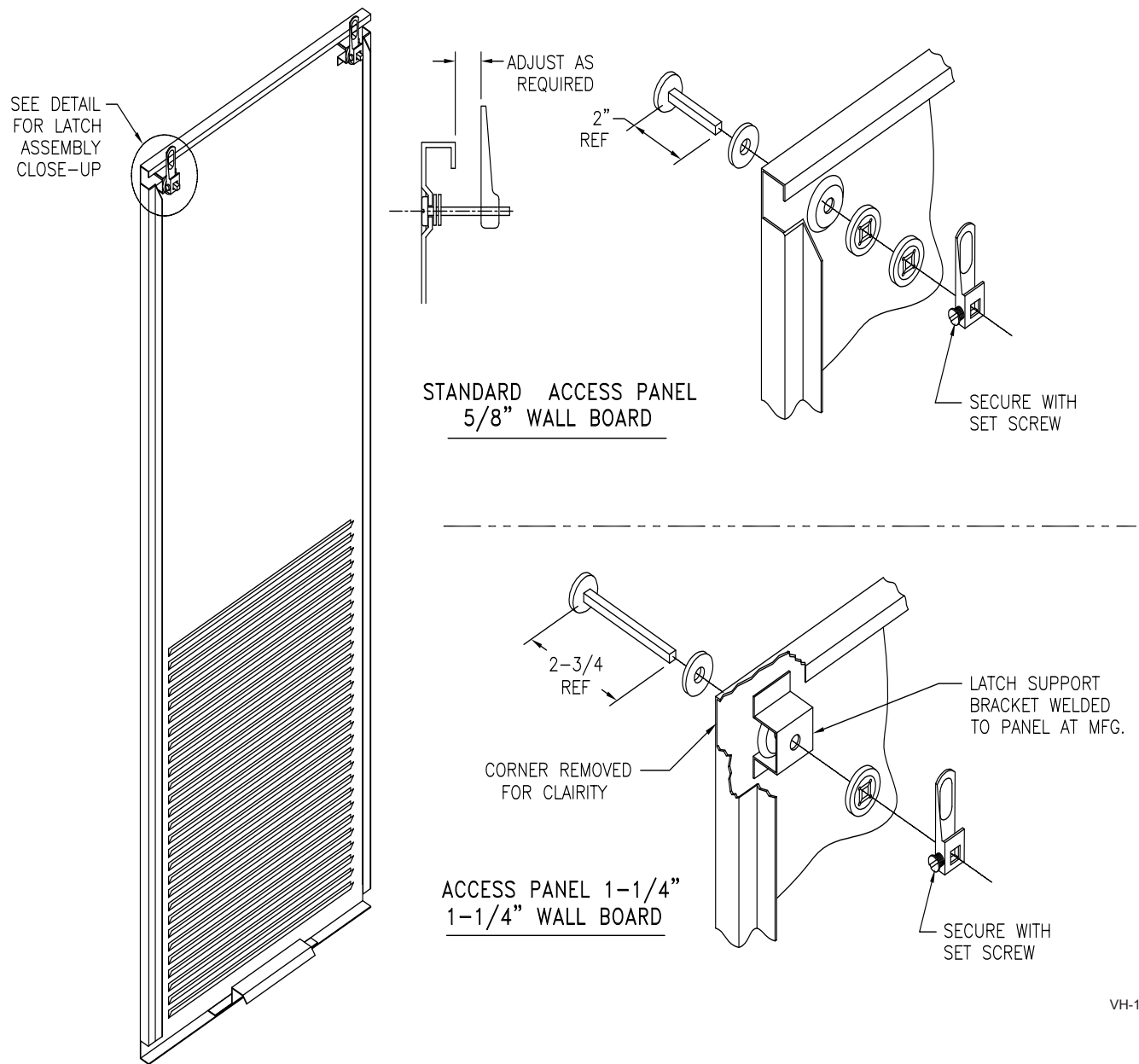

6

VH-106

FIGURE 50 - ASSEMBLY INSTRUCTIONS RETURN PANEL WITH LATCHES, QUICK OPENING OR TAMPER PROOF, MODEL VHC/VHM/VHS HIGH RISE FCU

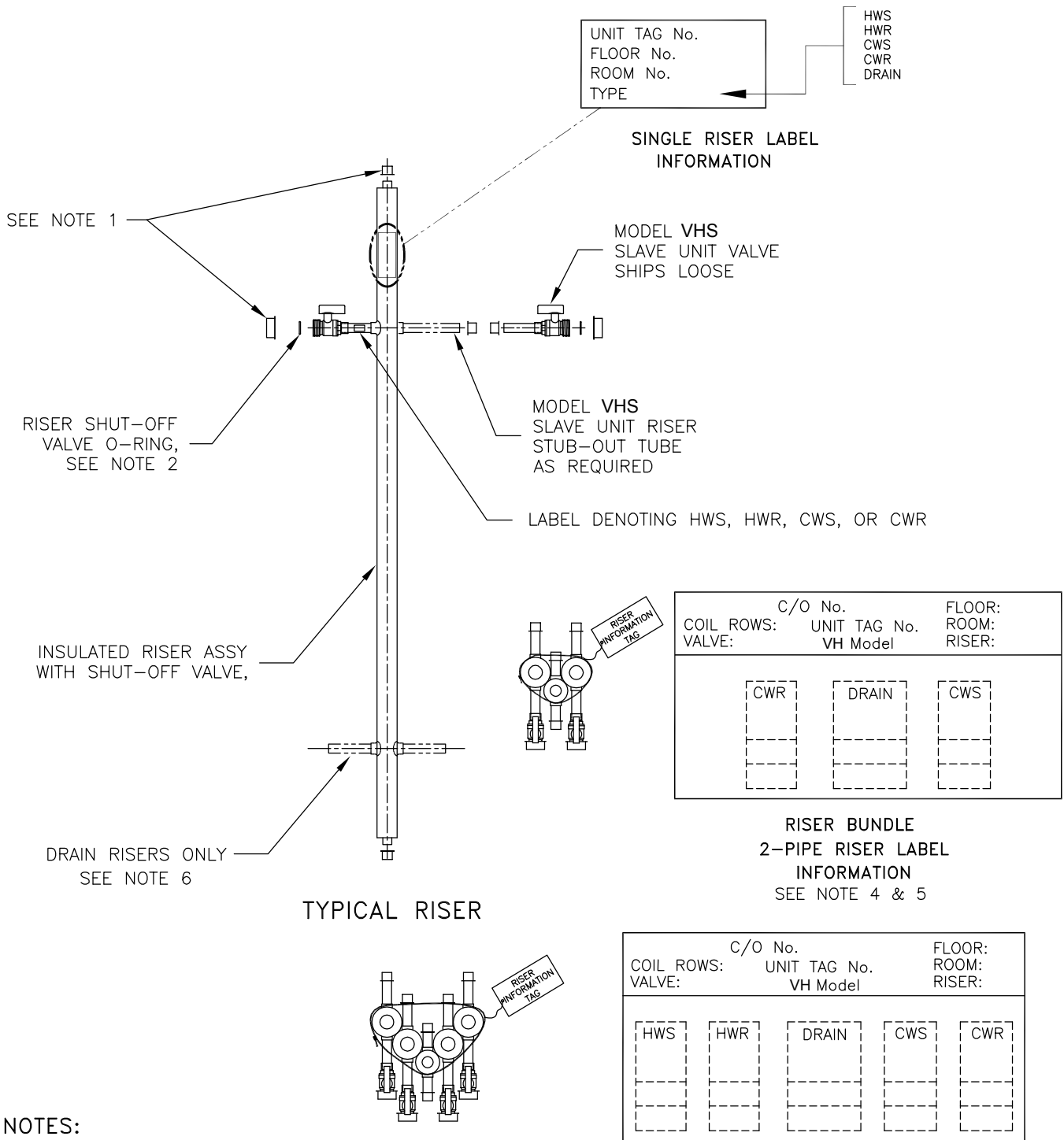

NOTES:

1. All risers and valves are shipped with protective caps. These caps should remain in place until installation of the unit.
2. Each valve is supplied with an O-ring that is bagged and shipped loose for field installation by others.
3. All risers are factory tested, and guaranteed to be leak free at time of shipment.
4. Riser information shown shall reflect matching unit identification labels.
5. VHS, Slave Units will have mirror image orientation and will be labeled in units.
6. Condensate P-Trap and hose clamps ships installed in unit for field connections to drain riser.

FIGURE 51 - PREPARATION INSTRUCTIONS FOR MODEL VHC/VHM VERTICAL HIGH RISE FCU "SHIP LOOSE" RISER ASSEMBLIES

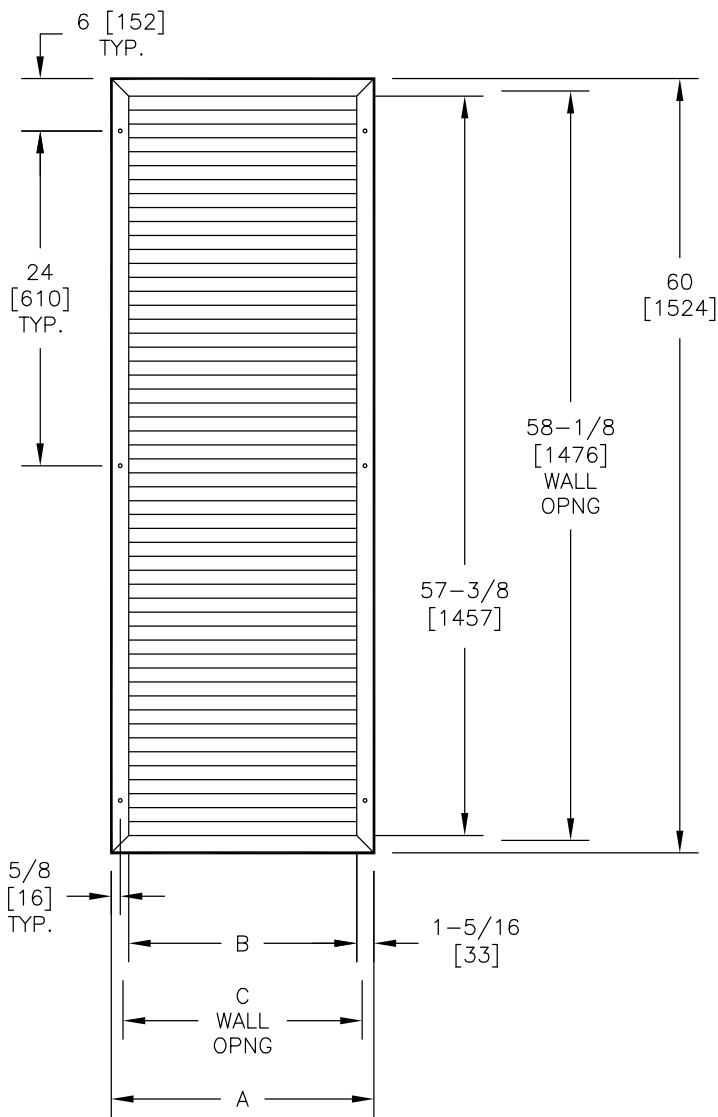

DIMENSIONS - In[mm]

UNIT SIZE	A	B	C
03/04	19-7/8 [505]	17-1/4 [438]	18-1/8 [460]
06/08	21-7/8 [556]	19-1/4 [489]	20-1/8 [511]
10/12	25-7/8 [657]	23-1/4 [591]	24-1/8 [613]

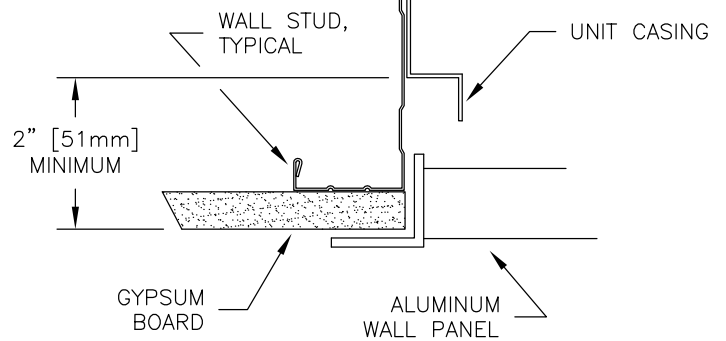

INSTALLATION DETAIL

(PARTIAL TOP VIEW)

NOTES:

1. All dimensions are Inches [mm]. Metric values are soft conversion.
2. All dimensions are ±1/4" [6mm].
3. All drawings are subject to change without prior notice.

4. Finished wall surface must be furred out from front of unit a minimum of 2" [51 mm].
5. Standard finish is white, and suitable for field painting.
6. Mounting hardware not included.

VH-013

FIGURE 52 - FULL LOUVERED ALUMINUM RETURN AIR/WALL PANEL MODEL VH VERTICAL HIGH RISE FAN COIL UNIT

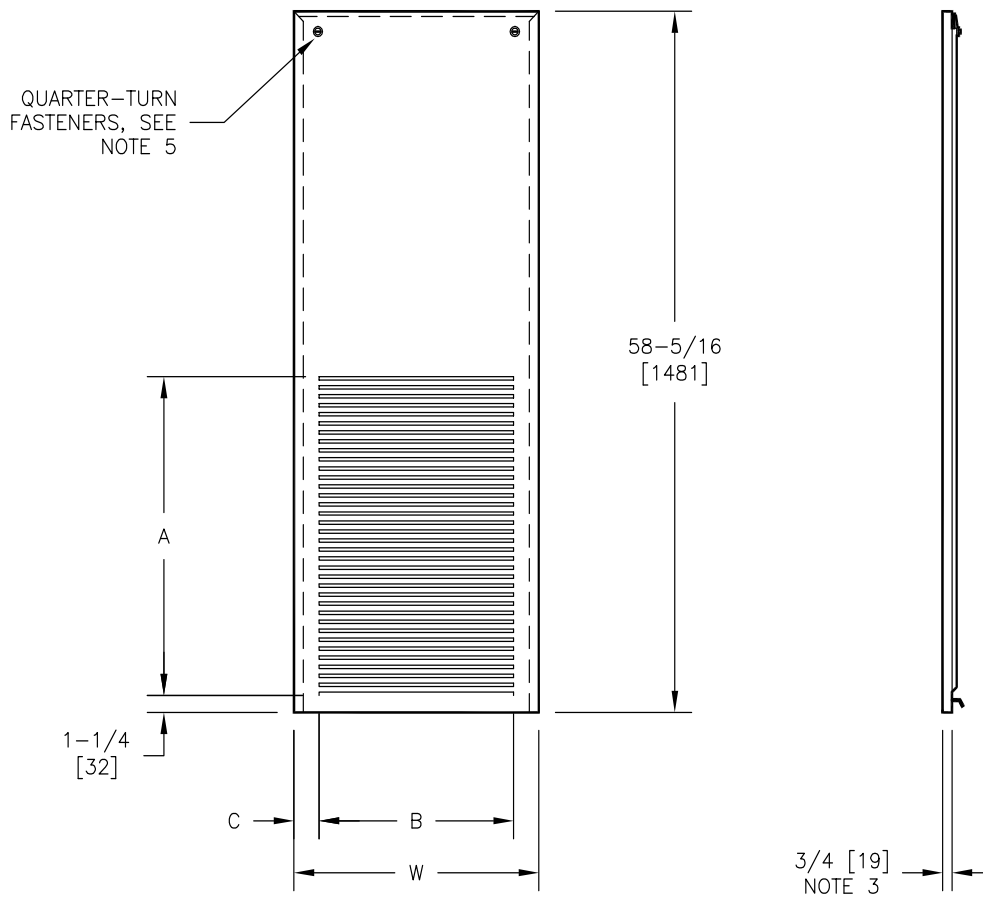

DIMENSIONS - In[mm]

UNIT SIZE	W	A	B	C	UNIT SIZE (6)	W	A	B	C
03/04	17-1/2 [445]	24-1/8 [613]	15 [381]	1-1/4 [32]	0306-0408	19-1/2 [495]	24-1/8 [613]	15 [381]	2-1/4 [57]
06/08	19-1/2 [495]	24-1/8 [613]	15 [381]	2-1/4 [57]	0310-0412	23-1/2 [597]	24-1/8 [613]	21 [533]	1-1/4 [32]
10/12	23-1/2 [597]	28-1/2 [724]	21 [533]	1-1/4 [32]	0610-0812	23-1/2 [597]	24-1/8 [613]	21 [533]	1-1/4 [32]

NOTES:

- All dimensions are Inches [mm]. Metric values are soft conversion.
- All dimensions are ±1/4" [6mm].
- Installed wall panels extends approximately 3/4" [19mm] from finished wall surface.
- Standard finish is Powder Coat Baked Enamel, color is "Pearl White Satin".
- Mounting hardware is factory installed. Refer to assembly instructions on page 73 for details.
- Sizes shown are for "up-sized" cabinet units used in Tandem Master & Tandem Slave pairs.

VH-012

FIGURE 53 - MODEL VH VERTICAL HIGH RISE FAN COIL UNIT STANDARD SURFACE MOUNT WALL PANEL

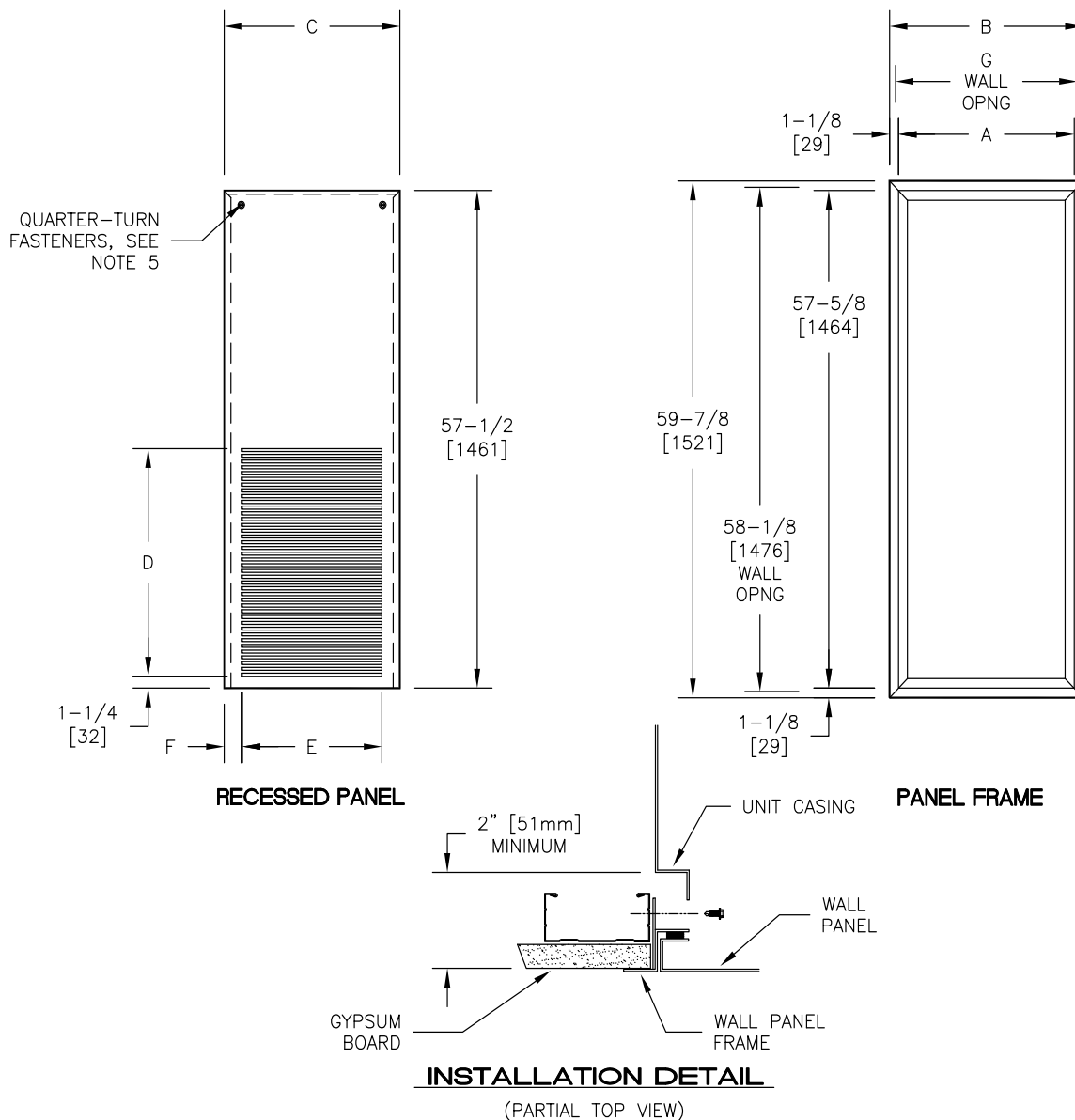

DIMENSIONS - In[mm]

UNIT SIZE	A	B	C	D	E	F	G	UNIT SIZE (6)	A	B	C	D	E	F	G
03/04	17-5/8 [448]	19-7/8 [505]	17-7/16 [443]	24-1/8 [613]	15 [381]	1-1/4 [32]	18-1/8 [460]	0306-0408	19-5/8 [498]	21-7/8 [556]	19-7/16 [494]	24-1/8 [613]	15 [381]	2-1/4 [57]	20-1/8 [511]
06/08	19-5/8 [498]	21-7/8 [556]	19-7/16 [494]	24-1/8 [613]	15 [381]	2-1/4 [57]	20-1/8 [511]	0310-0412	23-5/8 [600]	25-7/8 [657]	23-7/16 [595]	24-1/8 [613]	21 [533]	1-1/4 [32]	24-1/8 [613]
10/12	23-5/8 [600]	25-7/8 [657]	23-7/16 [595]	28-1/2 [724]	21 [533]	1-1/4 [32]	24-1/8 [613]	0610-0812	23-5/8 [600]	25-7/8 [657]	23-7/16 [595]	24-1/8 [613]	21 [533]	1-1/4 [32]	24-1/8 [613]

NOTES:

1. All dimensions are Inches [mm]. Metric values are soft conversion.
2. All dimensions are ±1/4" [6mm].
3. Finished wall surface must be furred out a minimum of 2" [51mm] from front of unit.
4. Standard finish is powder coat baked enamel. Color is "Pearl White Satin".
5. Mounting hardware is factory installed. Refer to assembly instructions on page 73 for details.
6. Sizes shown are for "up-sized" cabinet units used in Tandem Master & Tandem Slave pairs.

VH-014

FIGURE 54 - RECESSED WALL PANEL MODEL VH VERTICAL HIGH RISE FAN COIL UNIT

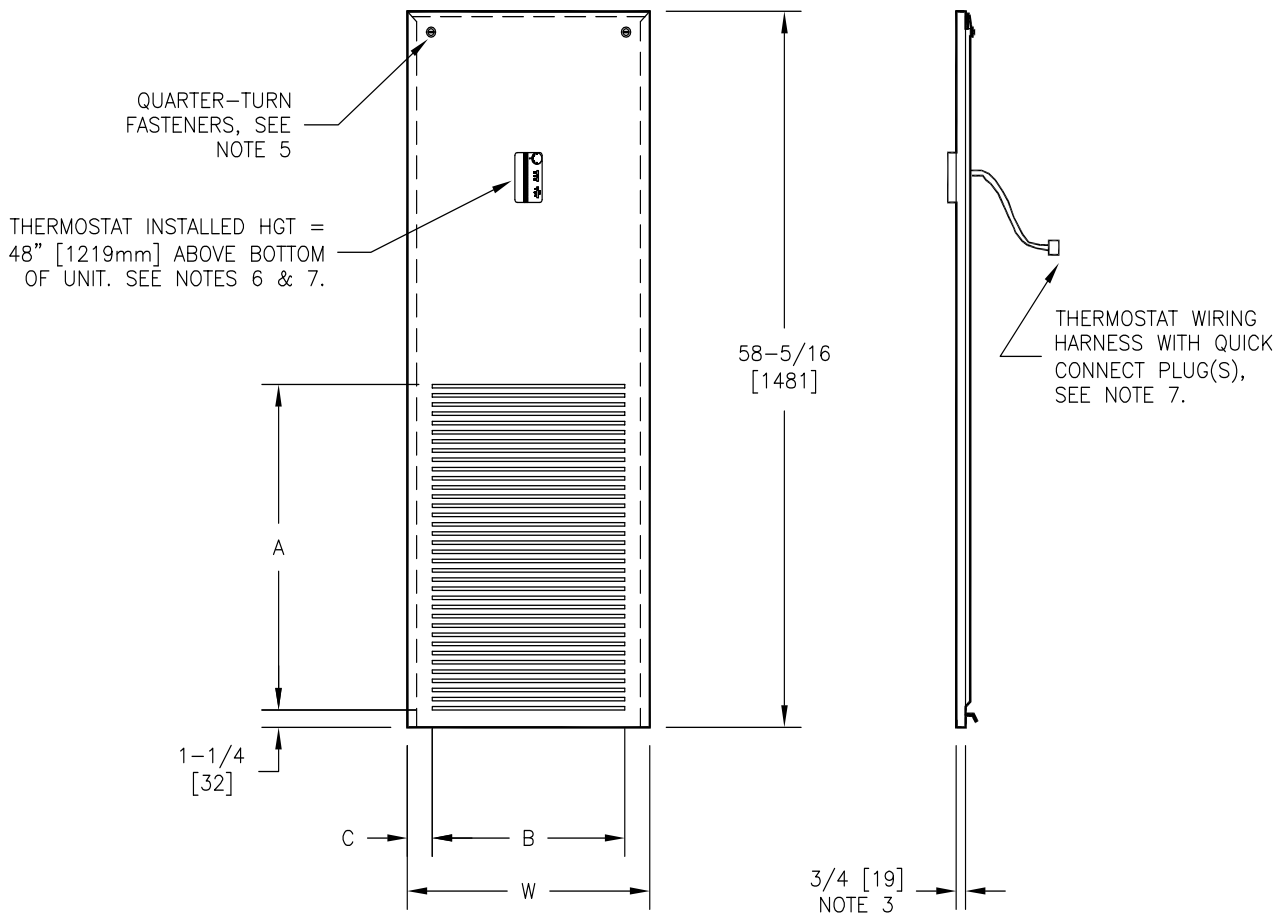

DIMENSIONS - In[mm]

UNIT SIZE	W	A	B	C	UNIT SIZE (8)	W	A	B	C
03/04	17-1/2 [445]	24-1/8 [613]	15 [381]	1-1/4 [32]	0306-0408	19-1/2 [495]	24-1/8 [613]	15 [381]	2-1/4 [57]
06/08	19-1/2 [495]	24-1/8 [613]	15 [381]	2-1/4 [57]	0310-0412	23-1/2 [597]	24-1/8 [613]	21 [533]	1-1/4 [32]
10/12	23-1/2 [597]	28-1/2 [724]	21 [533]	1-1/4 [32]	0610-0812	23-1/2 [597]	24-1/8 [613]	21 [533]	1-1/4 [32]

NOTES:

1. All dimensions are Inches [mm]. Metric values are soft conversion.
2. All dimensions are ±1/4" [6mm].
3. Installed wall panels extends approximately 3/4" [19mm] from finished wall surface.
4. Standard finish is Powder Coat Baked Enamel, color is "Pearl White Satin".
5. Mounting hardware is factory installed. Refer to assembly instructions on page for details.
6. Actual installed thermostat height is determined by unit installation method and may vary.
7. Thermostat is shipped loose for field installation by others.
8. Sizes shown are for "up-sized" cabinet units used in Tandem Master & Tandem Slave pairs.

VH-047

FIGURE 55 - MODEL VH VERTICAL HIGH RISE FAN COIL UNIT STANDARD RETURN WALL PANEL WITH ADA THERMOSTAT

TABLE 18 - DISCHARGE REGISTER PERFORMANCE DATA, VH STANDARD FCU 88" CABINET, SINGLE AND DOUBLE SUPPLY

SINGLE SUPPLY									
UNIT SIZE	CFM (SEE NOTE 5)	REGISTER DATA							
		W (IN.)	H (IN.)	Pv (in W.G.)	Pt (in W.G.)	Ps (IN W.G.)	NC	THROW (FT)	DROP (FT)
03	375	16	8	0.013	0.0370	0.0240	<20	16-36	9.5
04	450	16	8	0.018	0.0524	0.0344	<20	19-38	10
06	616	18	12	0.017	0.0523	0.0353	<20	18-45	13
08	860	18	12	0.024	0.0698	0.0458	26	26-52	16
10	966	22	14	0.017	0.0524	0.0354	21	27-62	21
12	1350	22	14	0.024	0.0697	0.0457	26	33-69	23

DOUBLE SUPPLY									
UNIT SIZE	CFM (SEE NOTE 5)	REGISTER DATA							
		W (IN.)	H (IN.)	Pv (in W.G.)	Pt (in W.G.)	Ps (IN W.G.)	NC	THROW (FT)	DROP (FT)
03	375	16	8	0.006	0.0170	0.0110	<20	11-24	10
04	450	16	8	0.008	0.0230	0.0150	<20	11-27	10.5
06	616	18	12	0.003	0.0072	0.0042	<20	10-35	11.5
08	860	18	12	0.006	0.0170	0.0110	<20	12-37	12
10	966	22	14	0.006	0.0170	0.0110	<20	13-42	12
12	1350	22	14	0.008	0.0230	0.0150	<20	14-45	14

NOTES:

1. NC data is at 0° deflection. For 22.5° deflection, add 1 NC. For 45° deflection, add 7 NC.
2. Throws are for velocities of 50 and 150 FPM at 0° deflection.
3. For 22.5° and 45° deflection, multiply by 0.67.
4. Drops are at 0° deflection. For 22.5° deflection, multiply by 0.85. For 45° deflection, multiply by 0.66.
5. Register Data is based on zero static and CRM show at high speed motor operation.
6. Data above does not reflect optional opposed blade damper information.

TABLE 19 - DISCHARGE REGISTER PERFORMANCE DATA, VH STANDARD FCU 79" CABINET, SINGLE AND DOUBLE SUPPLY

SINGLE SUPPLY									
UNIT SIZE	CFM (SEE NOTE 5)	REGISTER DATA							
		W (IN.)	H (IN.)	Pv (in W.G.)	Pt (in W.G.)	Ps (IN W.G.)	NC	THROW (FT)	DROP (FT)
03	375	16	8	0.013	0.0370	0.0240	<20	13-32	10
04	450	16	8	0.018	0.0524	0.0344	23	20-39	10.5
06	616	18	8	0.026	0.0765	0.0505	32	20-39	10.5
08	860	18	8	0.054	0.1624	0.1084	39	32-54	17

DOUBLE SUPPLY									
UNIT SIZE	CFM (SEE NOTE 5)	REGISTER DATA							
		W (IN.)	H (IN.)	Pv (in W.G.)	Pt (in W.G.)	Ps (IN W.G.)	NC	THROW (FT)	DROP (FT)
03	375	16	8	0.003	0.0072	0.0042	<20	8-25	9
04	450	16	8	0.005	0.0160	0.0110	<20	9-25	10
06	616	18	8	0.007	0.0180	0.0110	<20	13-30	10
08	860	18	8	0.015	0.0380	0.0230	21	18-39	11
10	966	22	8	0.015	0.0380	0.0230	<20	17-42	12.5
12	1350	22	8	0.019	0.0560	0.0370	21	21-45	14

NOTES:

1. NC data is at 0° deflection. For 22.5° deflection, add 1 NC. For 45° deflection, add 7 NC.
2. Throws are for velocities of 50 and 150 FPM at 0° deflection.
3. For 22.5° and 45° deflection, multiply by 0.67.
4. Drops are at 0° deflection. For 22.5° deflection, multiply by 0.85. For 45° deflection, multiply by 0.66.
5. Register Data is based on zero static and CRM show at high speed motor operation.
6. Data above does not reflect optional opposed blade damper information.

USE THIS CHART TO DETERMINE LENGTH OF SLOT NEEDED,
LENGTH IS MEASURED PARALLEL TO UNIT HEIGHT.
SEE ILLUSTRATIONS TO THE RIGHT.

UNIT SIZE	PIPE DIAMETER	INSTALLATION METHOD			
		(A)	(B)	(C)	(D)
03-04	3/4 TO 1-1/2	11-11/16	18-9/16	4-5/8	8-11/16
	2 TO 3	13-1/16	20	6-1/16	10
	ADD PER INCH OVER 100	5/8	11/16	1/4	11/16
06-08	3/4 TO 1-1/2	11-3/4	18-7/16	5-1/2	8-11/16
	2 TO 3	12-15/16	19-7/8	6	10
	ADD PER INCH OVER 100	9/16	11/16	1/4	11/16
10-12	3/4 TO 1-1/2	11-5/16	18-1/4	4-5/16	8-11/16
	2 TO 3	12-11/16	19-11/16	5-13/16	10
	ADD PER INCH OVER 100	1/2	9/16	1/4	11/16

USE THIS CHART TO DETERMINE WIDTH OF SLOT NEEDED,
WIDTH IS MEASURED PERPENDICULAR TO UNIT HEIGHT.
SEE ILLUSTRATIONS TO THE RIGHT.

PIPE DIAMETER		SLOT WIDTH			
		(A)	(B)	(C)	(D)
3/4"	2 PIPE	2-3/4"	N/A	8-3/4"	USE (C)
	4 PIPE	N/A	2-3/4"	16"	USE (C)
1"	2 PIPE	3"	N/A	9"	USE (C)
	4 PIPE	N/A	3"	16-1/4"	USE (C)
1-1/4"	2 PIPE	3-1/4"	N/A	9-1/4"	USE (C)
	4 PIPE	N/A	3-1/4"	16-1/2"	USE (C)
1-1/2"	2 PIPE	3-1/2"	N/A	9-1/2"	USE (C)
	4 PIPE	N/A	3-1/2"	16-3/4"	USE (C)
2"	2 PIPE	4"	N/A	10"	USE (C)
	4 PIPE	N/A	4"	17-1/4"	USE (C)
2-1/2"	2 PIPE	4-1/2"	N/A	10-1/2"	USE (C)
	4 PIPE	N/A	4-1/2"	17-3/4"	USE (C)
3"	2 PIPE	5"	N/A	11"	USE (C)
	4 PIPE	N/A	5"	18-1/4"	USE (C)

NOTE:
SOME UNITS MAY HAVE DIFFERENT LENGTH AND DIAMETERS OF PIPE.
ALWAYS USE THE LONGEST AND/OR LARGEST DIAMETER
WHEN DETERMINING SLOT LENGTHS AND WIDTHS.

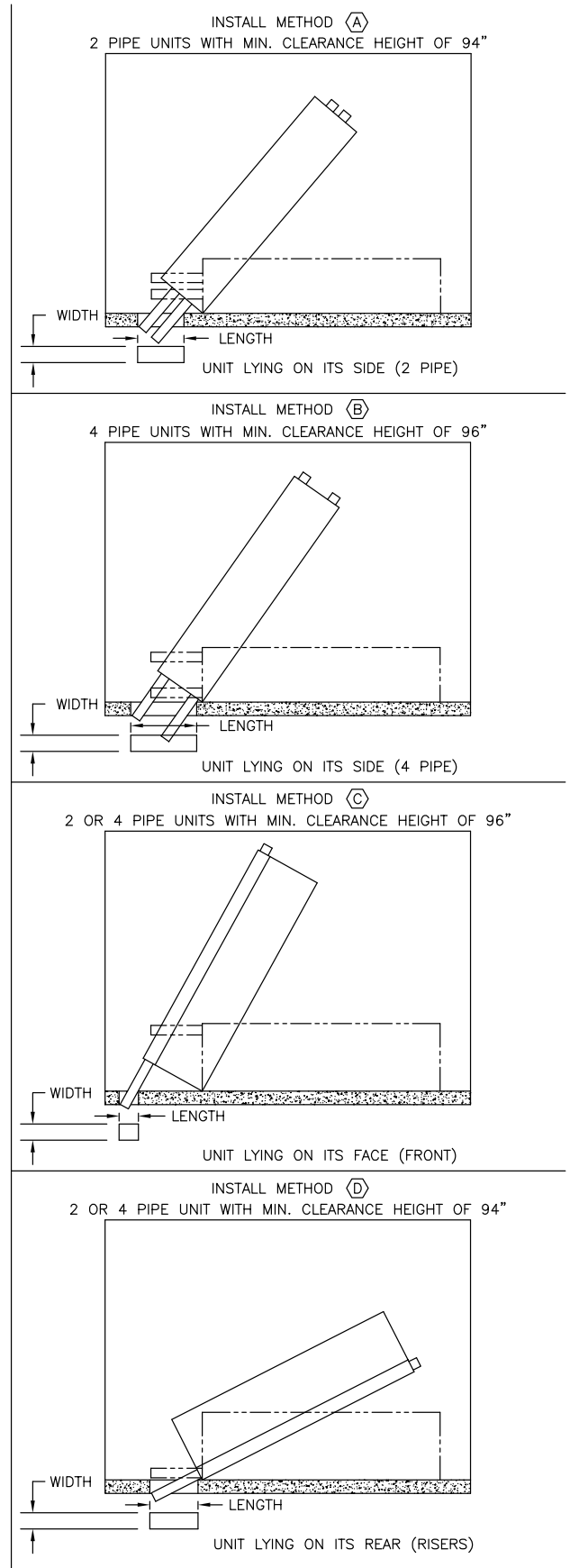
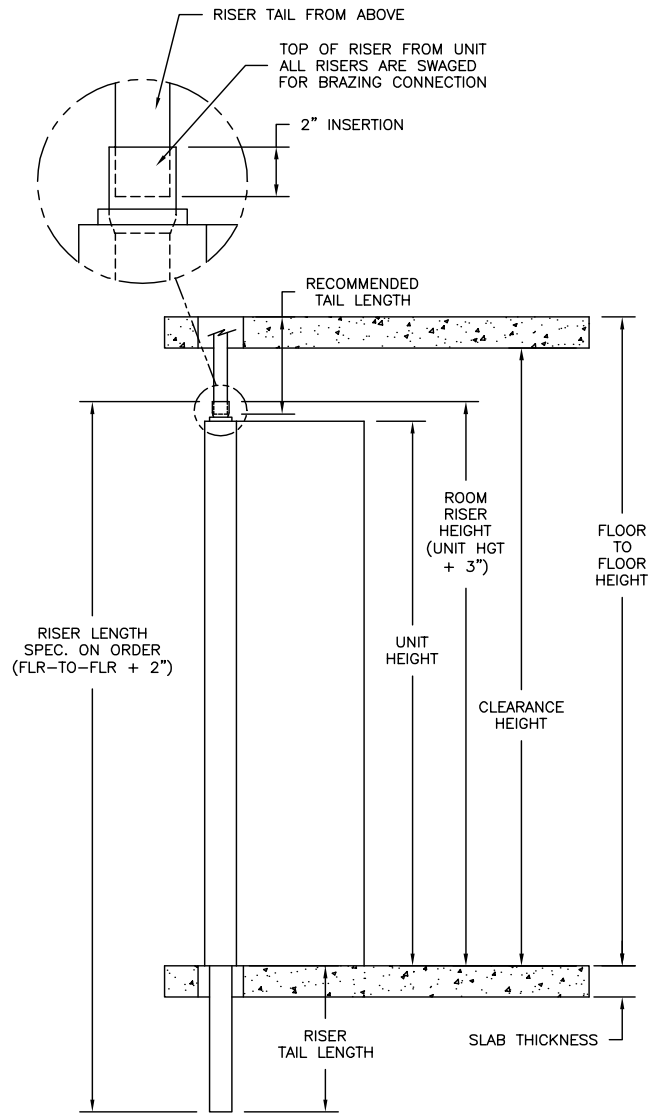

FIGURE 56 - SUGGESTED RISER FLOOR OPENINGS VHC & VHM

VH-109



FLOOR TO FLOOR HEIGHT:
DISTANCE FROM THE TOP OF ONE SLAB TO THE TOP OF THE SLAB ON THE NEXT FLOOR.

CLEARANCE HEIGHT:
HEIGHT AVAILABLE ON ONE FLOOR, FLOOR TO FLOOR HEIGHT LESS THE SLAB THICKNESS.

ROOM RISER HEIGHT:
DISTANCE FROM THE FLOOR TO THE TOP OF THE RISER, ALL RISERS EXTEND 3" BEYOND THE TOP OF THE UNIT.

UNIT HEIGHT:
DISTANCE FROM FLOOR TO THE TOP OF THE UNIT.

RISER LENGTH:
OVERALL LENGTH OF THE RISERS (SPECIFIED ON ORDER), USE THE FORMULA BELOW TO DETERMINE RISER LENGTH. RISERS ARE AVAILABLE IN LENGTHS FROM 91" TO 120" IN 1" INCREMENTS.

SLAB THICKNESS:
THICKNESS OF FLOOR, INCLUDING ANY HANGING OBSTRUCTIONS, SEE CONTRACTORS PLANS TO DETERMINE THICKNESS.

RISER TAIL LENGTH:
DISTANCE THAT RISERS EXTEND BELOW UNIT.

VH-110

NOTE:
IF RECOMMENDED RISER LENGTH EXCEEDS 120", RISER EXTENSIONS WILL BE REQUIRED.

FIGURE 57 - RISER TERMINOLOGY, MODEL VHC, VHM, VHA UNITS

VERTICAL HI-RISE TANDEM UNITS VHA/VHB INSTALLATION INSTRUCTIONS

Receipt & Initial Installation

General

This publication details the installation requirements for the Enviro-Pac dual unit configuration of the Vertical High Rise, VH, unit assembly. Use of this document for systems or products not manufactured or supplied by ENVIRO-TEC shall not be applicable.

All products covered by this manual have been tested in accordance with UL1479 (2012) - Fire Tests Of Through Penetration Fire Stop Assemblies. Specific information about the ENVIRO-PAC VHA/VHB UL1479 (2012) listing may be viewed on the Warnock Hersey Listed Product Directory at <https://whdirectory.intertek.com>. Reference WH file number JCI/PF60-01.

Specific ETL listed model numbers may be found in the current ETL Listed Mark Directory at <http://www.intertek.com/directories/>.

For other VH product installation and operational instructions, refer to IOM-FCUVH.

The Installation Instructions found within this manual have been specifically drawn and detailed to meet the requirements of UL1479 (2012). Some jurisdictions may have additional installation requirements above and beyond those detailed in this document; consult with the authority having jurisdiction for specific additional requirements. In all cases, the instructions detailed in this document must be followed to maintain the UL 1479 (2012) fire rating.

Installation

1. In order to achieve the 1 hour fire rating, ENVIRO-PAC unit assembly must be installed into a minimum 1-hour fire rated wall assembly of gypsum and steel stud, gypsum and wood stud, concrete, or masonry construction with a minimum overall thickness of 4-3/4". The wall assembly shall extend into the unit spacer plate. When applicable, attach studs of the wall to the unit spacer plate with sheet metal screws spaced nominally 12" O.C. When built of gypsum construction, the following minimum requirements must be met.
 - a. Studs – Wood or steel studs nominal 3-1/2" thick, spaced maximum 24" O.C.

- b. Gypsum Board – Minimum 5/8" Type X Gypsum board with a minimum of one layer. Gypsum board must be installed on each side of the wall assembly.

2. Place unit assembly in its desired location. Check riser number, floor number, room number, and unit tag number against the tag label on the unit, making sure that the unit assembly is installed with the space between the two units centered in the wall between each room.
3. Anchor unit assembly to floor through unit bottom. Due to floor leveling, some shimming may be necessary so unit is plumb and square to floor/ceiling.
4. Install floor stud reception channels up to unit sides at the connector plate.
5. Install ceiling stud reception channel over the unit assembly, leaving space for riser penetration.
6. Install the wall studs into the recess in the unit assembly using #6 x 1/2 drywall screws spaced as necessary.



Avoid placing screws where they may penetrate the risers, coil, piping, or electrical system.

7. Install balance of the studs into ceiling/floor reception channels at a spacing to meet project specifications and local, state, or national codes. In no cases should stud spacing be greater than 24" O.C.
8. Install studs from top of unit to ceiling. Locates studs at each unit corner.
9. Make necessary electrical and plumbing connections to unit.
10. Two installation configurations may be used for the ENVIRO-PAC units. The following details standard installation per *Figure 58 on page 84*.
 - a. Install minimum 5/8" Type X gypsum board to all exposed sides of the unit exterior, including top and front. Gypsum panels may be applied directly to unit casing or may be furred out for plumbness. Any supply air, outside air, or thermostat openings shall be let-in as necessary.

- b. The gypsum panel installed to the face of the unit should be applied directly to the front of the unit, unless a wall recessed return air grille is used, in which case this panel will be furred-out. Any supply air, return air, or thermostat openings shall be let-in as necessary.
- c. Attach gypsum board to unit with sheet metal screws spaced 8" O.C. around the perimeter and 12" O.C. in the field, ensuring that screws are not located where they might penetrate interior working of unit.
- d. Gypsum board shall be tightly butted against the wall assembly on all exposed sides, including top of unit.

11. For alternate installation per *Figure 59 on page 84*, unit framing must be installed to top of unit.

- a. Install minimum 25 GA, nominal 3-1/2" wide, steel track to the top of the fan coil unit, at top front and two top sides as shown in *Figure 59 on page 84*.
- b. Attach steel track using sheet metal screws spaced 12" O.C.
- c. Install identical steel track to the ceiling or floor assembly using appropriate anchors. Friction fit minimum 25 GA nominal 3-1/2" steel studs into the top and bottom track and secure with pan head screws.
- d. Install one stud at each corner of the fan coil unit.
- e. Install gypsum board to the front and side of the fan coil unit as described in Step 10.
- f. Extend the gypsum board to the ceiling or floor assembly, attaching to steel studs and track with Type S screws spaced maximum 8" O.C.

12. Risers shown in the standard location. Risers may be installed on the left or right side of Unit A. Wall construction should remain the same, regardless of riser location.

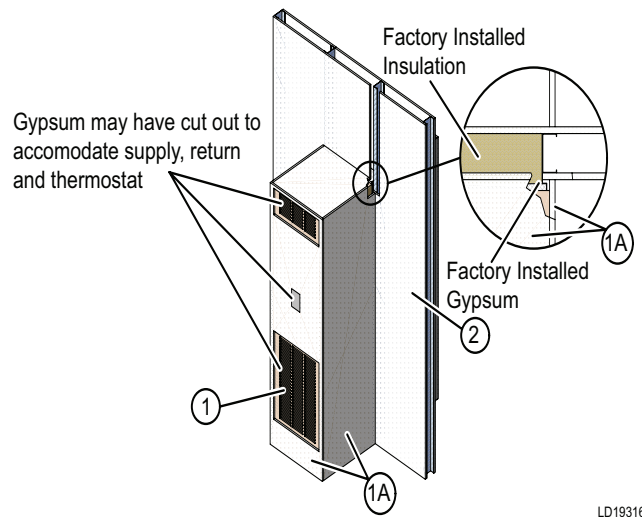

LD19316

FIGURE 58 - STANDARD INSTALLATION

Attached to pre-existing ceiling or floor assembly

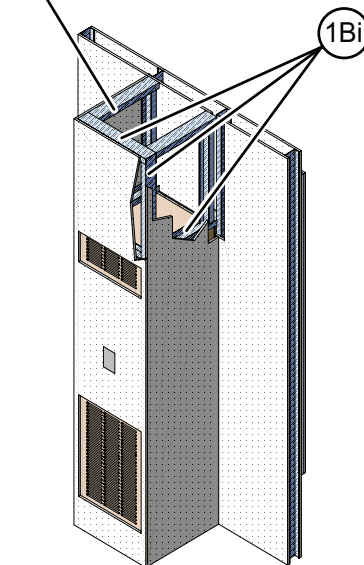

LD19316

FIGURE 59 - ALTERNATE INSTALLATION

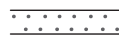
 = 5/8" TYPE-X GYPSUM BOARD, FIELD SUPPLIED
 = 5/8" TYPE-X GYPSUM BOARD, FACTORY SUPPLIED

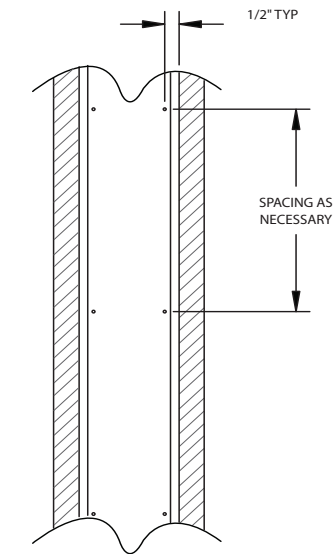

SECTION "B-B"

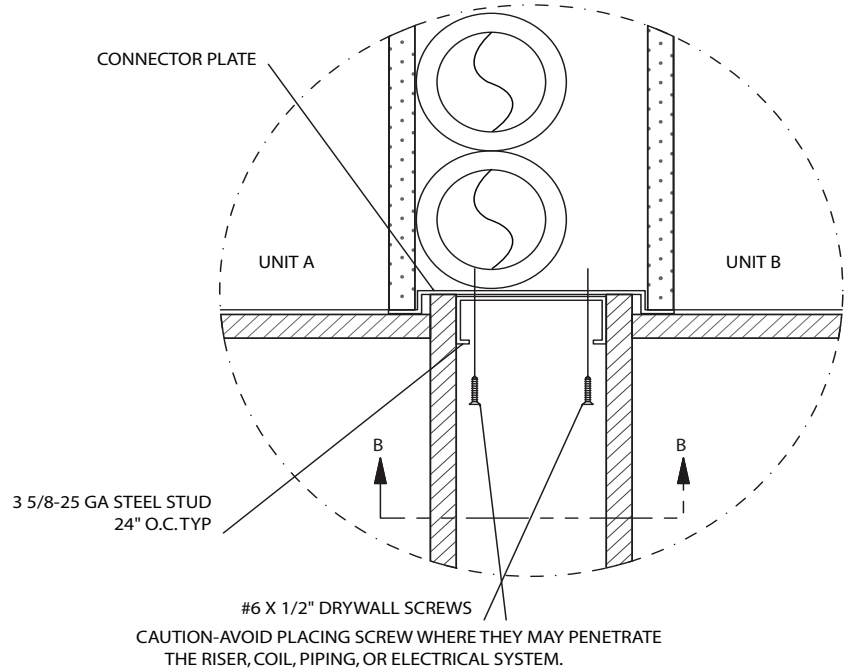

DETAIL-A

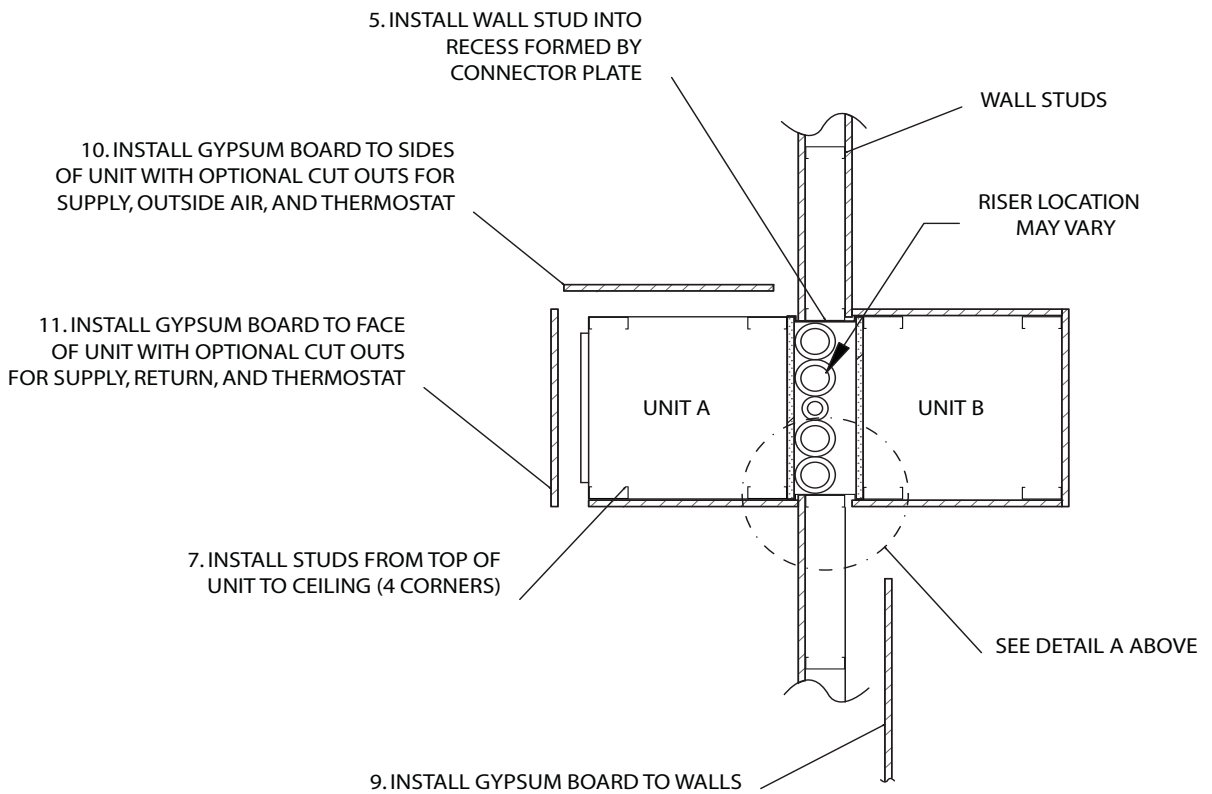

PLAN VIEW

SHEET 2 OF 2
 PX-70-0001
 LD13947

FIGURE 60 - MOUNTING DETAILS

NOTES

The following factors can be used to convert from English to the most common SI Metric values.

TABLE 20 - SI METRIC CONVERSION

MEASUREMENT	MULTIPLY ENGLISH UNIT	BY FACTOR	TO OBTAIN METRIC UNIT
Capacity	Tons Refrigerant Effect (ton)	3.516	Kilowatts (kW)
Power	Horsepower	0.7457	Kilowatts (kW)
Flow Rate	Gallons / Minute (gpm)	0.0631	Liters / Second (l/s)
Length	Feet (ft)	0.3048	Meters (m)
	Inches (in)	25.4	Millimeters (mm)
Weight	Pounds (lbs)	0.4538	Kilograms (kg)
Velocity	Feet / Second (fps)	0.3048	Meters / Second (m/s)
Pressure Drop	Feet of Water (ft)	2.989	Kilopascals (kPa)
	Pounds / Square Inch (psi)	6.895	Kilopascals (kPa)

TEMPERATURE

To convert degrees Fahrenheit (°F) to degrees Celsius (°C), subtract 32° and multiply by 5/9 or 0.5556.

Example: $(45.0^{\circ}\text{F} - 32^{\circ}) \times 0.5556 = 27.2^{\circ}\text{C}$

To convert a temperature range (i.e., a range of 10°F) from Fahrenheit to Celsius, multiply by 5/9 or 0.5556.

Example: $10.0^{\circ}\text{F range} \times 0.5556 = 5.6^{\circ}\text{C range}$

ENVIRO-TEC is a registered trademark of Johnson Controls, Inc. in the United States of America and other countries. Other trademarks used herein may be trademarks or registered trademarks of other companies.

Catalog: ET115.24-NOM4 (615) Supersedes ET115.24-NOM4 (315)
© 2015 Johnson Controls, Inc. P.O. Box 423, Milwaukee, WI 53201 Printed in USA
www.enviro-tec.com

